

VSFMX40

OM# OM1100586

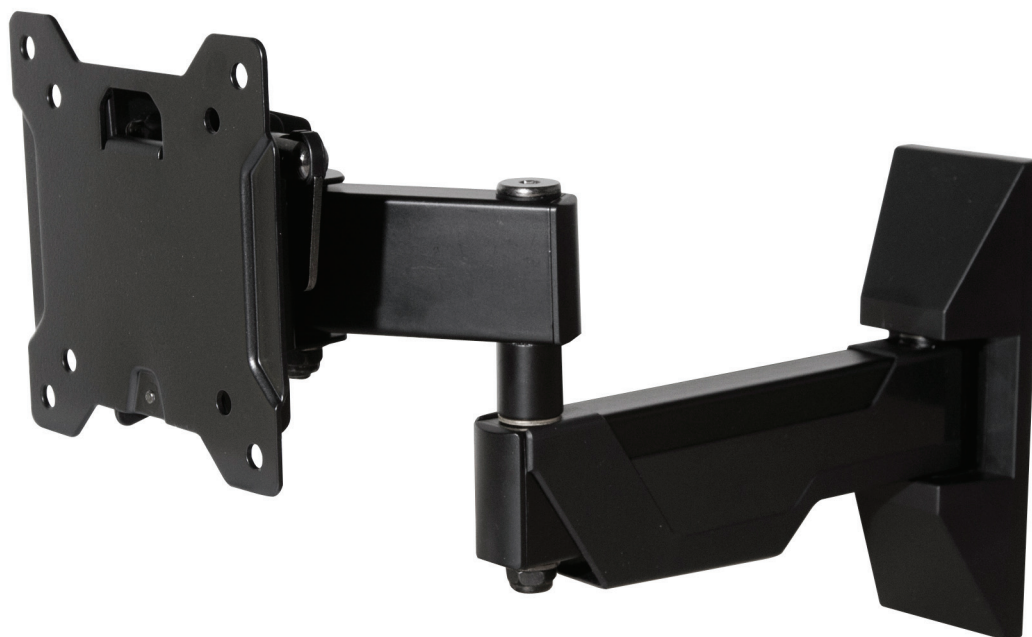

INSTRUCTION MANUAL
РУКОВОДСТВО ПО
ЭКСПЛУАТАЦИИ



Max screen size: 42"
Max weight 40 lbs – 18.1 kg
CAUTION: DO NOT EXCEED
MAXIMUM LISTED WEIGHT
CAPACITY. SERIOUS INJURY
OR PROPERTY DAMAGE MAY
OCCUR!
For TVs larger than 37" (94
cm), ensure TV weight and
VESA hole pattern are within
mount specifications.

Максимальный размер экрана: 42 "
Максимальный вес 18.1 кг
Внимание: не превышайте максимальный
указанной вес. Это может привести к серьезным
травмам или **МОЖЕТ ПРИВЕСТИ К ПОЛОМКЕ!**
Повторное использование. Переработка
Для телевизоров с диагональю более 37" (94 см),
убедитесь что вес телевизора и отверстия VESA
находятся в пределах спецификаций этого товара.



Reduce.Reuse.Recycle

1-800-MOUNT-IT (USA ONLY)



DISCLAIMER - WARNING INFORMATION

Disclaimer – OmniMount Systems, Inc. has extended every effort to ensure to accuracy and completeness of this manual. However, OmniMount Systems, Inc. does not claim that the information covers all installation or operational variables. The information contained in this document is subject to change without notice or obligation of any kind. Regarding the information contained herein, OmniMount Systems, Inc. makes no representation of warranty, expressed or implied, and assumes no responsibility for accuracy, sufficiency, or completeness of the information contained in this document.

Wall Mounts

WARNING: FAILURE TO READ, THOROUGHLY UNDERSTAND, AND FOLLOW ALL INSTRUCTIONS CAN RESULT IN SERIOUS PERSONAL INJURY, DAMAGE TO PERSONAL PROPERTY, OR VOIDING OF FACTORY WARRANTY!

It is the responsibility of the installer to ensure all components are properly assembled and installed using the instructions provided. If you do not understand these instructions or have any questions or concerns, please contact customer service at 1-800-668-6848 or info@omnimount.com. Do not attempt to install or assemble this product if the product or hardware is damaged or missing. In the event that replacement parts or hardware are needed, please contact Customer Service at 1-800-668-6848 or info@omnimount.com. International customers needing assistance should contact the Dealer from which they purchased the product.

The included hardware is designed for use on vertical walls constructed of wood studs or solid concrete. A wood stud wall is defined as consisting of a minimum of 2x4 wooden studs (2" wide by 4" deep) with a maximum of 5/8" drywall. The included hardware is not designed for use with metal studs or cinderblock walls. If you're uncertain about the construction of your wall, then please consult a qualified contractor or installer for assistance. For a safe installation, the wall you are mounting to must support 4 times the weight of the total load. If not, then the surface must be reinforced to meet this standard. The installer is responsible for verifying that the wall structure and hardware used in any installation method will safely support the total load.

РУССКИЙ

Ограничена отговорност - OmniMount Systems, Inc. има за цел да направи настоящото ръководство точно и пълно. Въпреки това, OmniMount Systems, Inc. не претендира, че съдържащата се в него информация обхваща всички детайли, условия или варианти. Нито че са посочени всички възможни непредвидени обстоятелства във връзка с монтажа или използването на този продукт. Информацията, съдържаща се в този документ, подлежи на промяна без предизвестие или каквото и да е задължение. OmniMount Systems, Inc. не дава изрична или подразбираща се гаранция относно тук представената информация. OmniMount Systems, Inc. не носи отговорност за точността, завършеността или обстойността на информацията, съдържаща се в този документ.

Стенни стойки

ПРЕДУПРЕЖДЕНИЕ: АКО НЕ ПРОЧЕТЕТЕ, НЕ ВНИКНЕТЕ, ЗА ДА РАЗБЕРЕТЕ И НЕ СЛЕДВАТЕ ВСИЧКИ УКАЗАНИЯ, ТОВА МОЖЕ ДА ДОВЕДЕ ДО ТЕЖКО НАРАНЯВАНЕ, ПОВРЕДА НА ЛИЧНО ИМУЩЕСТВО ИЛИ АНУЛИРАНЕ НА ФАБРИЧНАТА ГАРАНЦИЯ!

Монтажникът носи отговорност, за да провери дали всички компоненти са правилно сглобени и монтирани с помощта на предоставените указания. Ако не разбирате инструкциите или имате някакви опасения или въпроси, моля свържете се с отдела за обслужване на клиенти на 1-800-668-6848 или на info@omnimount.com.

Не се опитвайте да монтирате или сглобявате този продукт ако продуктът или металните крепежни елементи са повредени или липсват. В случай, че са необходими резервни части или крепежни елементи, моля, свържете се с отдела за обслужване на клиенти на 1-800-668-6848 или info@omnimount.com. Клиенти от чужбина, които имат нужда от помощ, трябва да се свържат с продавача, от който са закупили продукта.

Приложените крепежни елементи са предназначени за употреба с окачване на вертикална стена от дървени греди или зидария (твърд бетон). Под дървени греди в случая се има предвид стена, изградена от греди с минимален размер 51 мм или 2 инча x 102 мм или 4 инча и максимум 16 мм или 5/8 инча см суха зидария. Приложените крепежни елементи не са предназначени за употреба с окачване на стени от метални греди или сгърбетон. Ако не сте сигурни за конструкцията на стената, моля, потърсете съвет от квалифициран монтажник или строителен специалист. За да осигурите безопасна инсталация, стената, на която ще монтирате уреда, трябва да може да издържа 4 пъти общия товар на продукта. Ако не е така, тогава повърхността трябва да се укрепи, за да отговаря на стандартите. Монтажникът, носи отговорност за това да провери дали стената и използваните при монтажа крепежни елементи са в състояние безопасно да поддържат общия товар на продукта.

WEIGHT CAPACITY

USE WITH FLAT PANELS EXCEEDING THE MAXIMUM WEIGHT CAPACITY OF THIS PRODUCT MAY RESULT IN PRODUCT FAILURE CAUSING POSSIBLE INJURY AND OR PROPERTY DAMAGE.

ИСПОЛЗОВАНИЕ ТЕЛЕВИЗИОННЫХ ПАНЕЛЕЙ, ВЕС КОТОРЫХ ПРЕВЫШАЕТ МАКСИМАЛЬНО ДОПУСТИМЫЙ ВЕС НАГРУЗКИ ЭТОГО ИЗДЕЛИЯ, МОЖЕТ СТАТЬ ПРИЧИНОЙ ПОЛОМКИ ИЗДЕЛИЯ И ПОЛЕЧЬ ВОЗМОЖНЫЕ ТРАВМЫ И МАТЕРИАЛЬНЫЙ УЩЕРБ.

For TVs larger than 37" (94 cm), ensure TV weight and VESA hole pattern are within mount specifications.

Для телевизоров с диагональю более 37" (94 см), убедитесь что вес телевизора и отверстия VESA находятся в пределах спецификаций этого товара.

CAUTION!
MAXIMUM WEIGHT CAPACITY



CAUTION!
MAXIMUM SCREEN SIZE



TOOLS NEEDED - NOT INCLUDED

Tools Needed
Необходимые инструменты

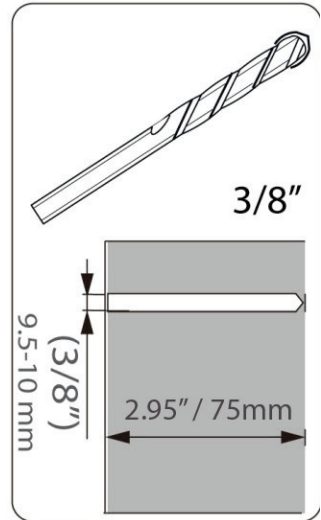
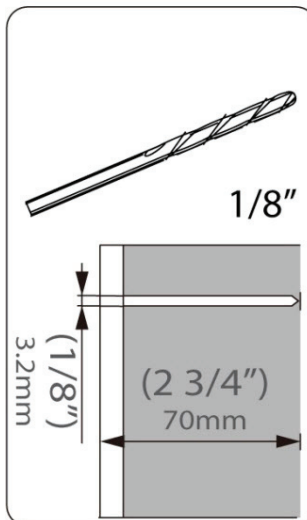
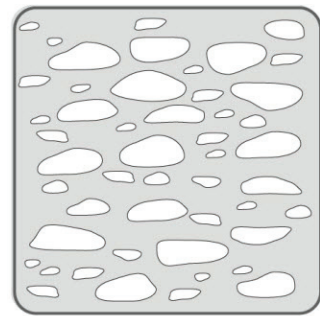
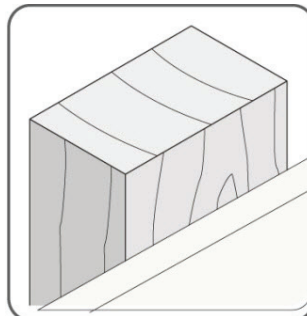
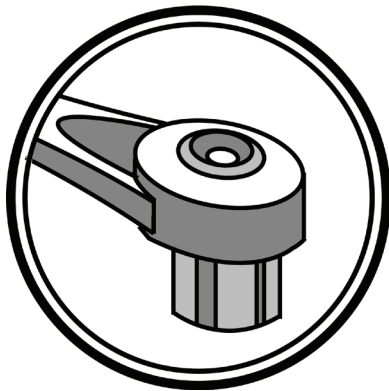
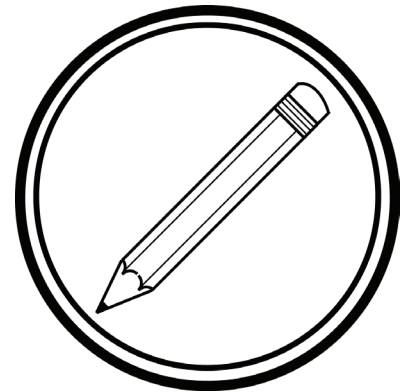
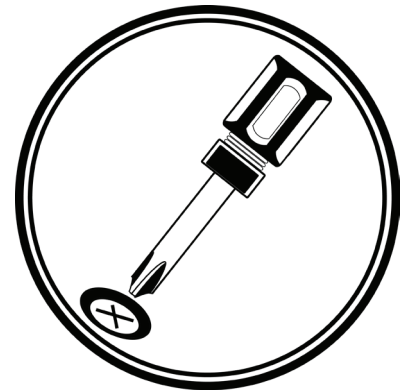
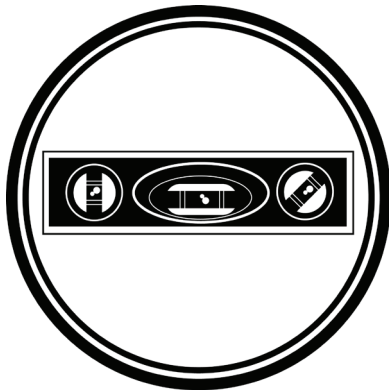

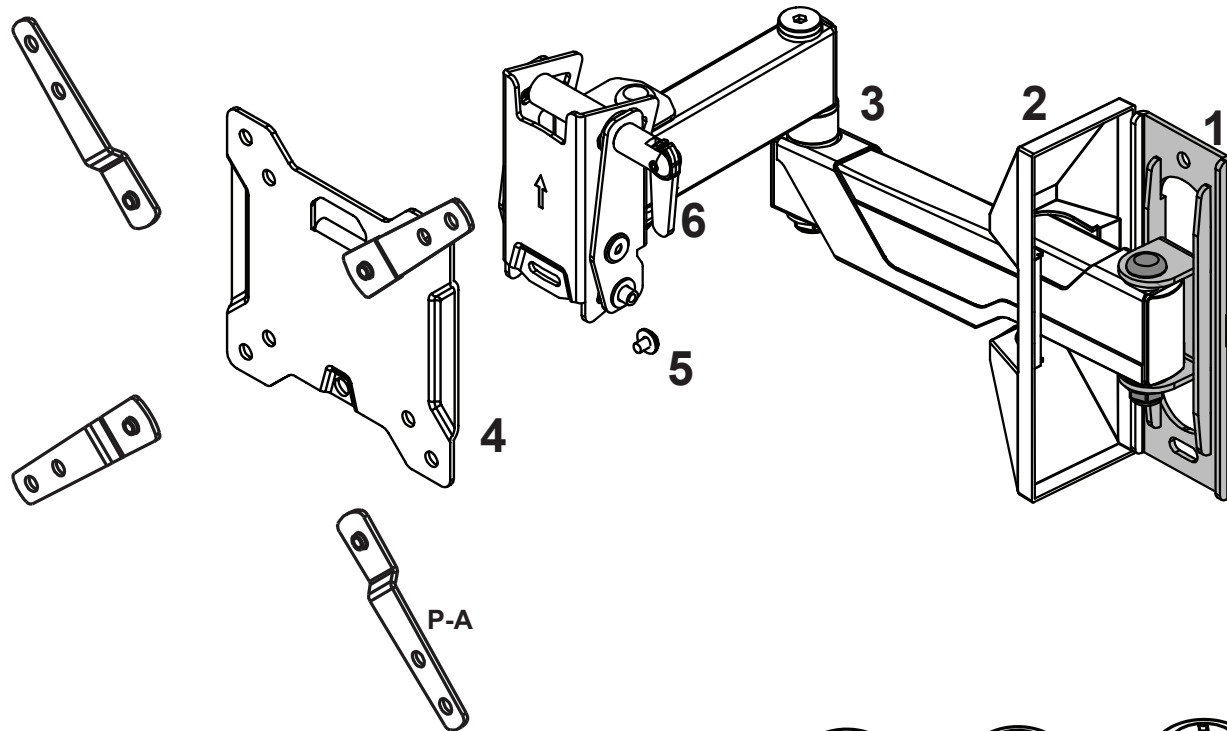

SCREWS/HARDWARE FOR FLAT PANEL 697-563-00

Part #	Qty	Description
M-A	4	Philips Screws M4 x 12mm
M-B	4	Philips Screws M5 x 12mm
M-C	4	Philips Screws M6 x 12mm

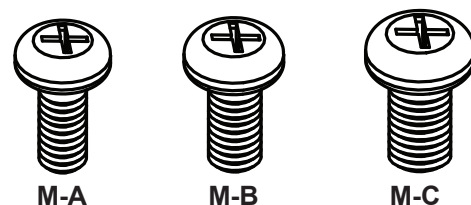

SCREWS/HARDWARE FOR WALL MOUNTING 697-610

Part #	Qty	Description
W-A	2	Lag Bolt
W-B	2	Wall Anchor

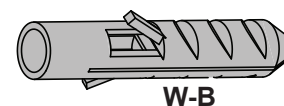

SCREWS/HARDWARE FOR PRODUCT 697-704

Part #	Qty	Description
P-A	4	V200A Adapter
P-B	4	Vesa Adapter Screws



Contents

Part #	Qty	Description
1	1	Wall Plate
2	1	Wall Plate Cover
3	1	Arm Assembly (with cable management)
4	1	Monitor Plate
5	1	Monitor Plate Screw/Washer
6	1	Tilt Tension Handle

M8M5KIT

Qty	Description
4	M5x20mm
4	Thread Reducer

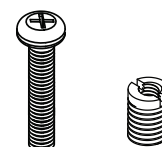

STEP 1

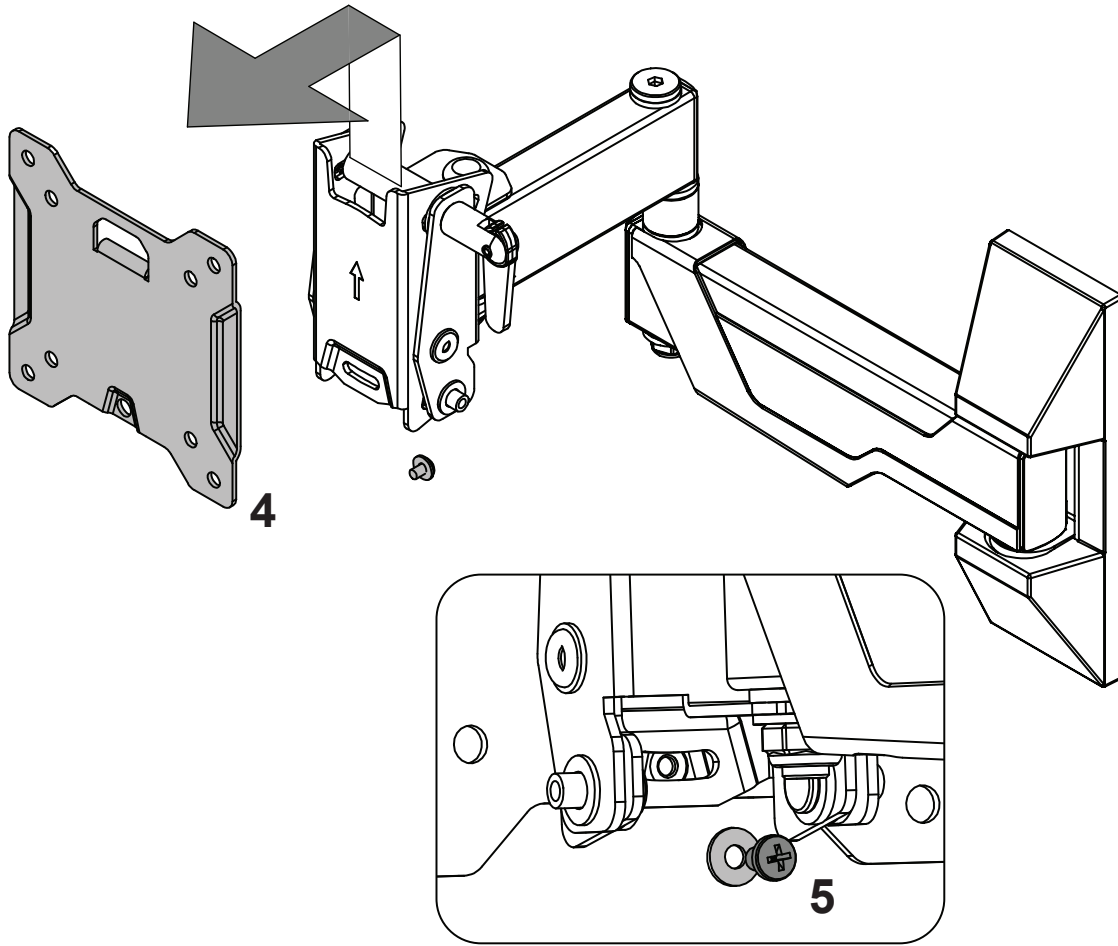

STEP 2

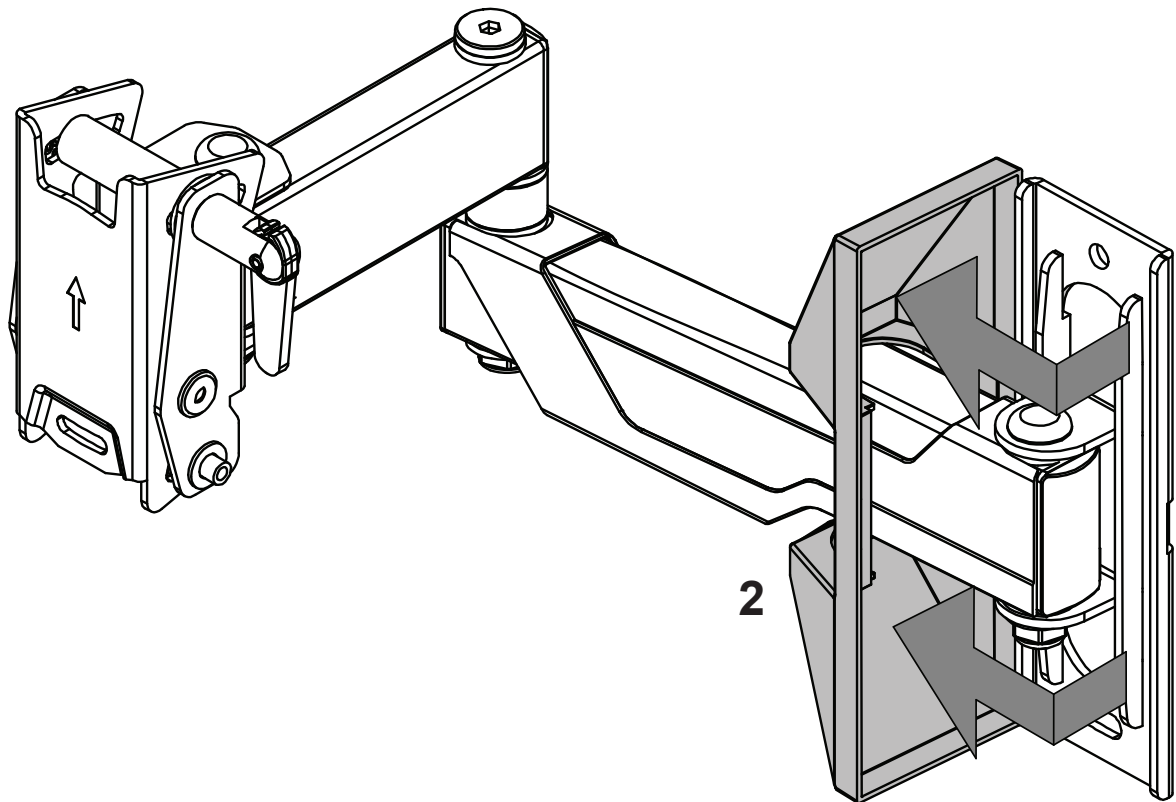

A

page 7
Страница 7

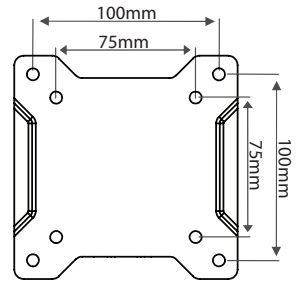
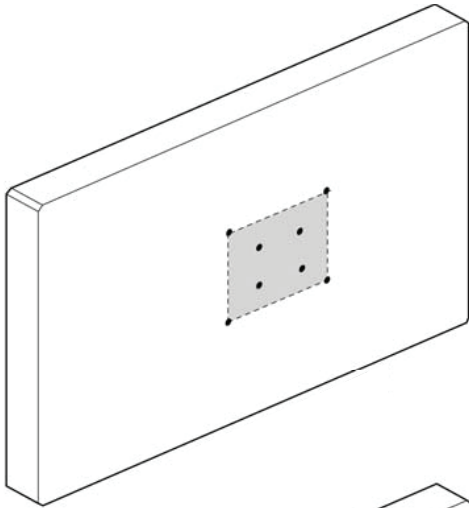

B

page 8-9
Страница 8-9

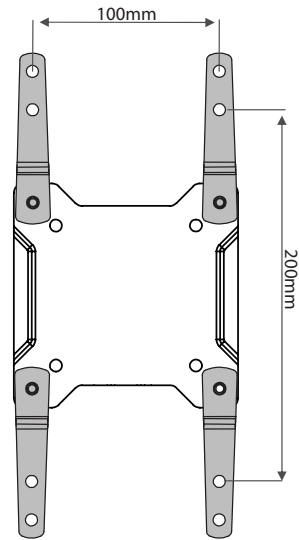
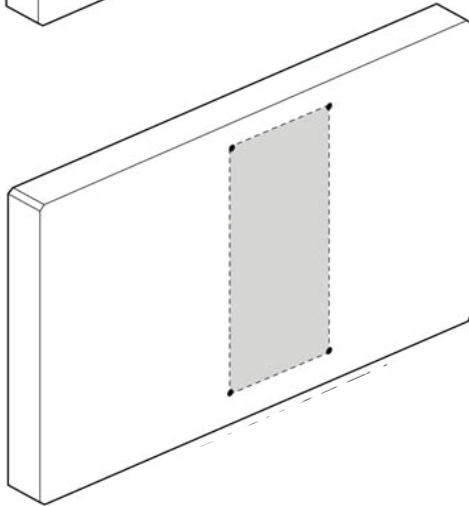

C

page 8-9
Страница 8-9

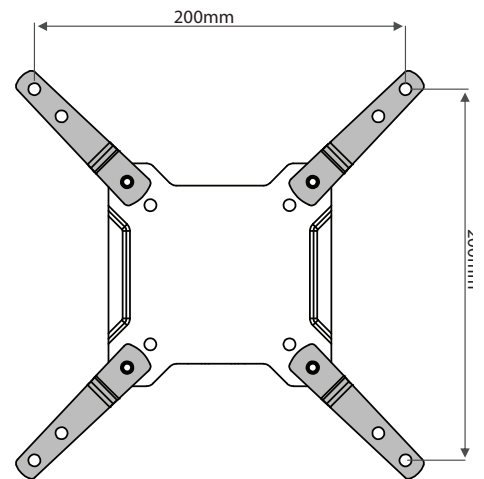
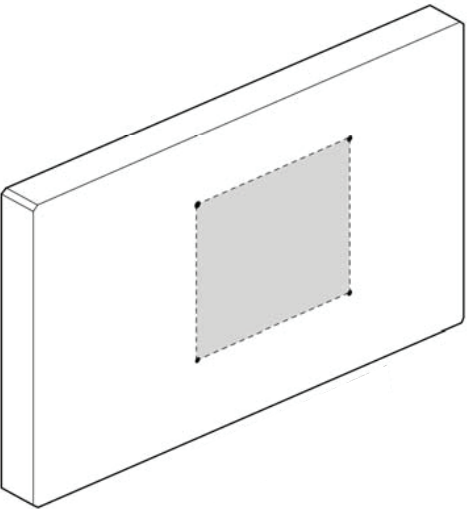

D

page 8-9
Страница 8-9

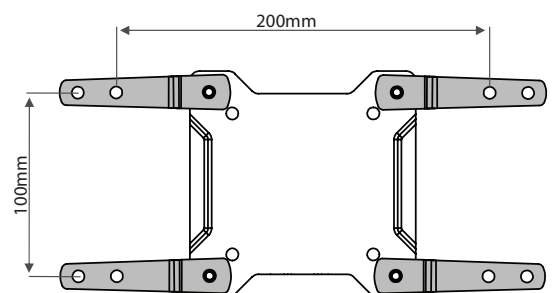
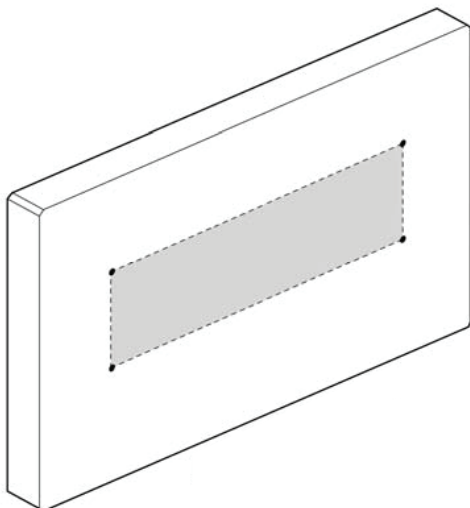

STEP 3 A: ≤ 100mm X 100mm

Attach monitor using monitor hardware, M-A, M-B, etc...

Прикрепите монитор с помощью крепежа для монитора, M-A, M-B, и т. д.

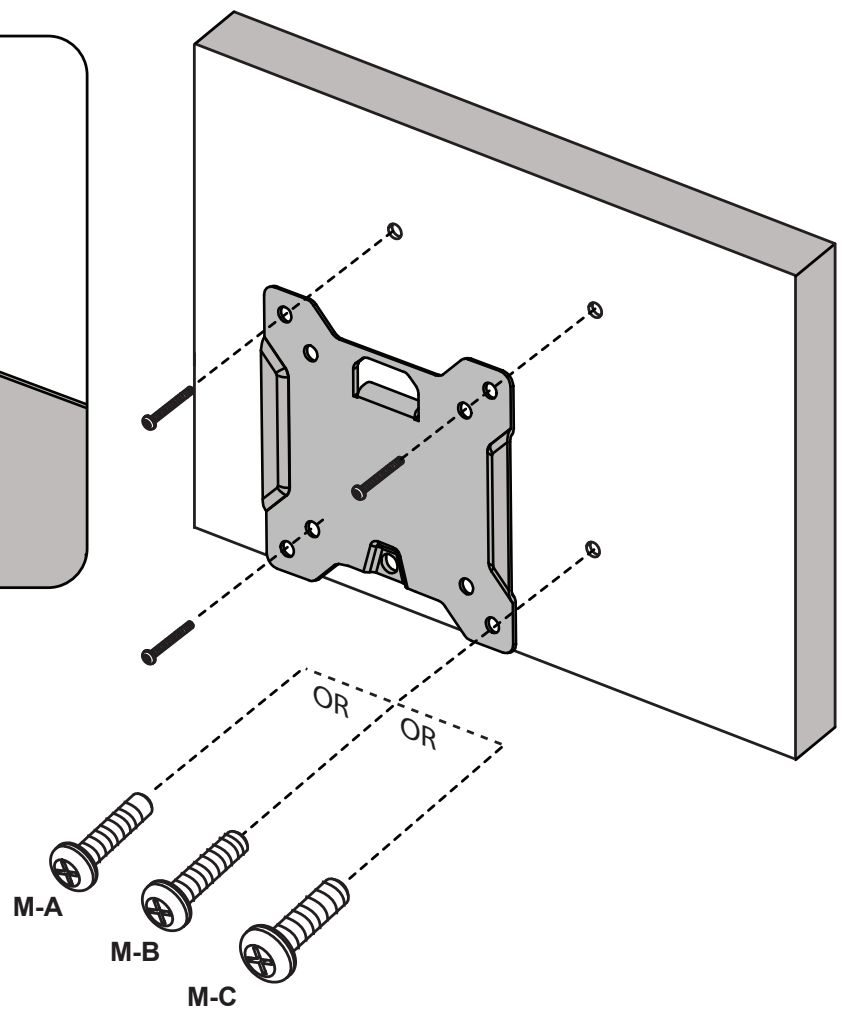
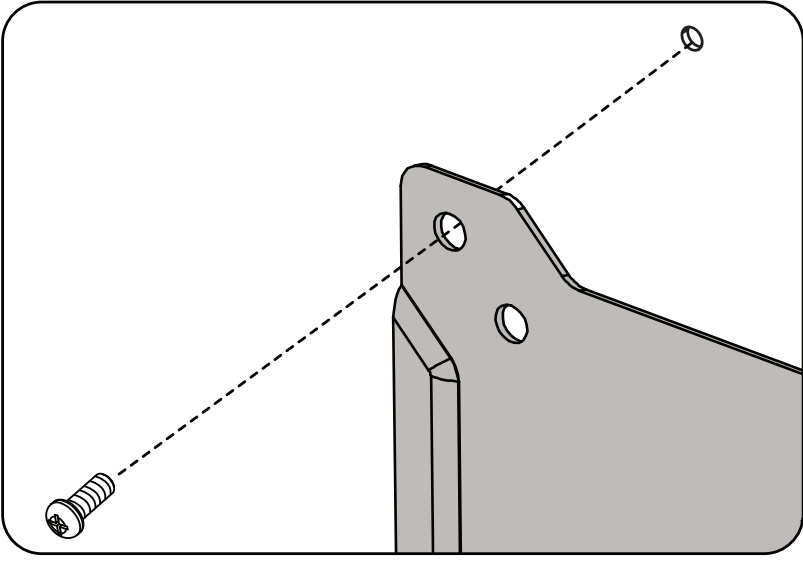
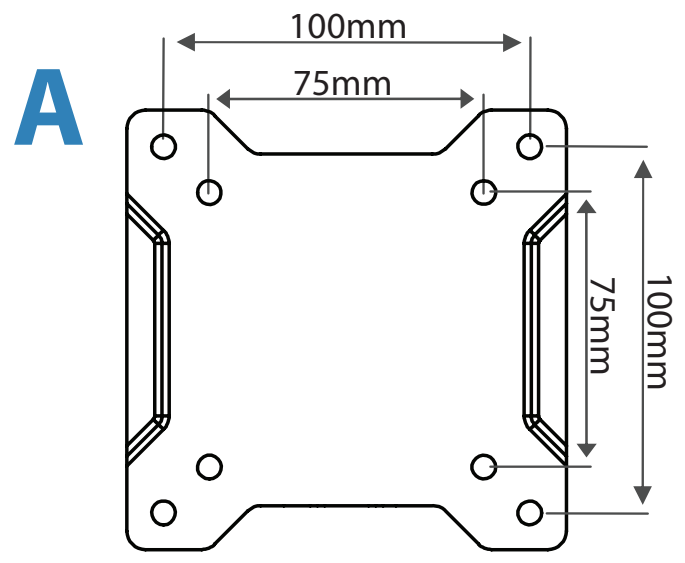

continue installation on page 10
Продолжить монтаж на стр 10

STEP 3 B/C/D: > 100mm X 100mm - INSTALL ADAPTERS

Install Adapters

Установите удлинители

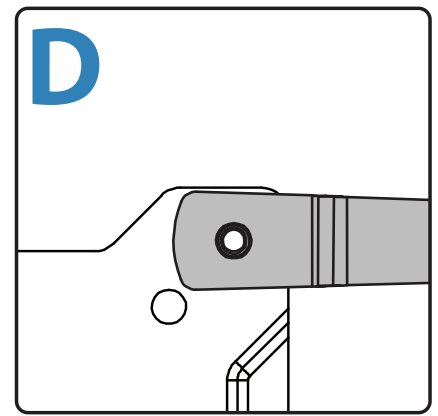
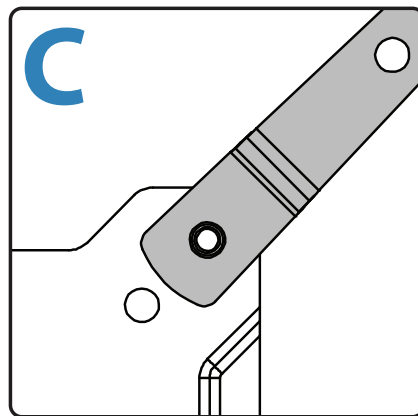
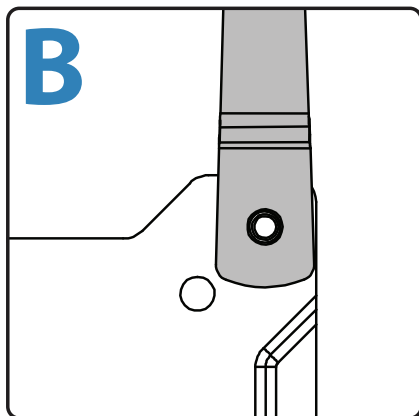
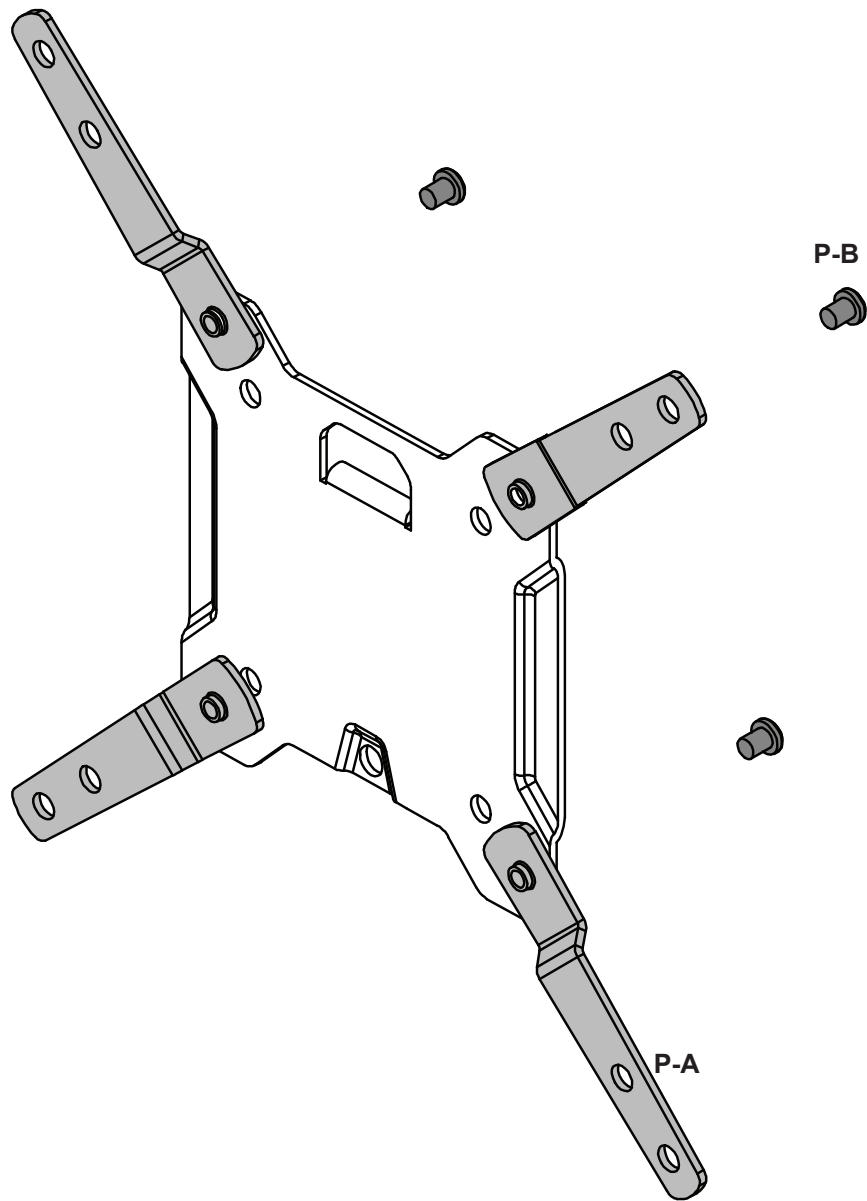

STEP 3 B/C/D: > 100mm X 100mm

Attach monitor using monitor hardware, M-A, M-B, etc...

Прикрепите монитор с помощью крепежа для монитора, M-A, M-B, и т. д.

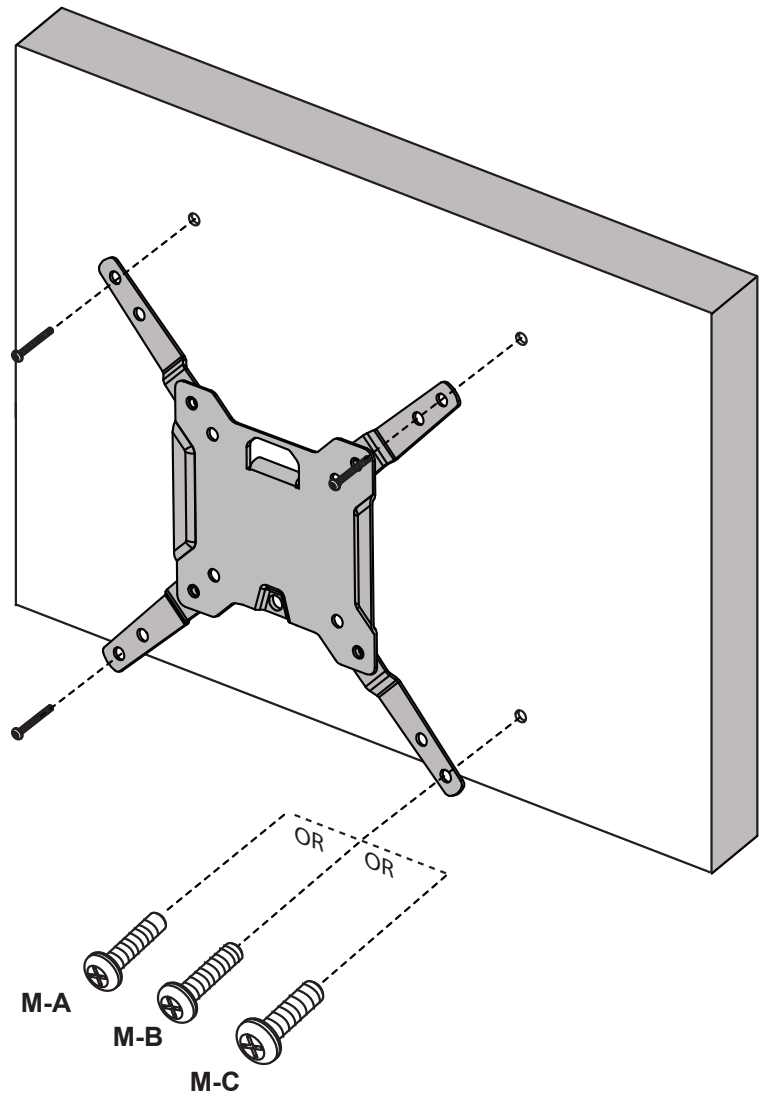
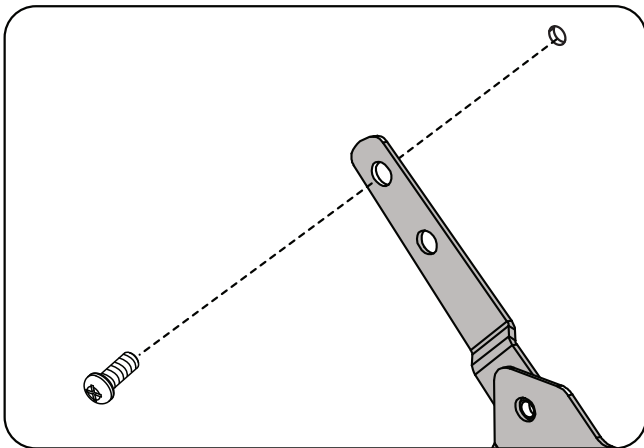
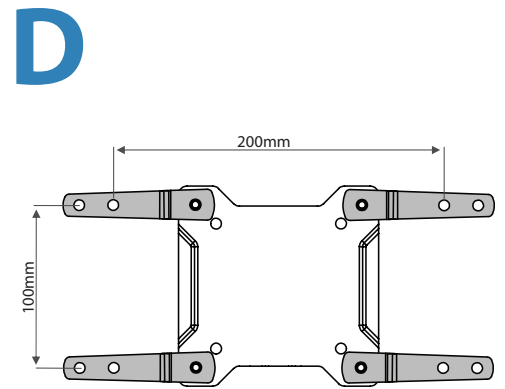
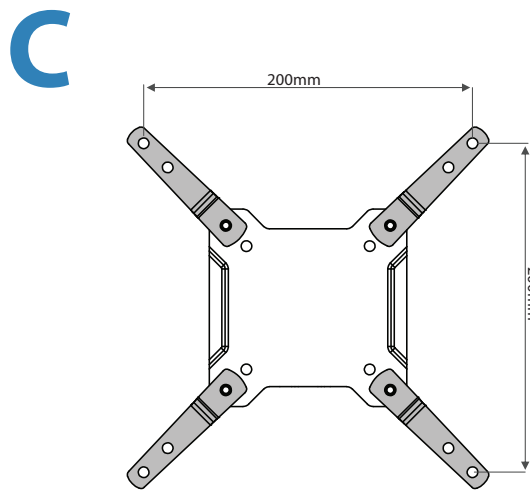
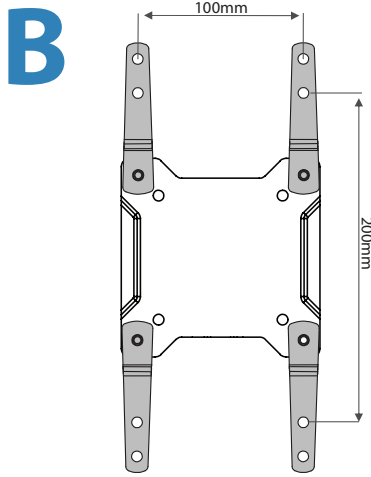

continue installation on page 10
Продолжить монтаж на стр 10

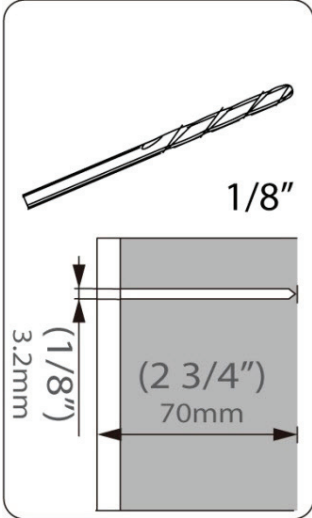
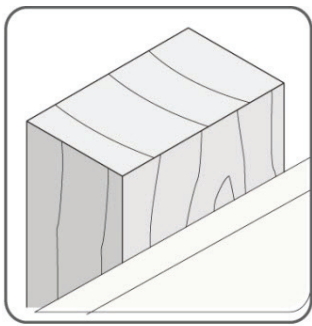
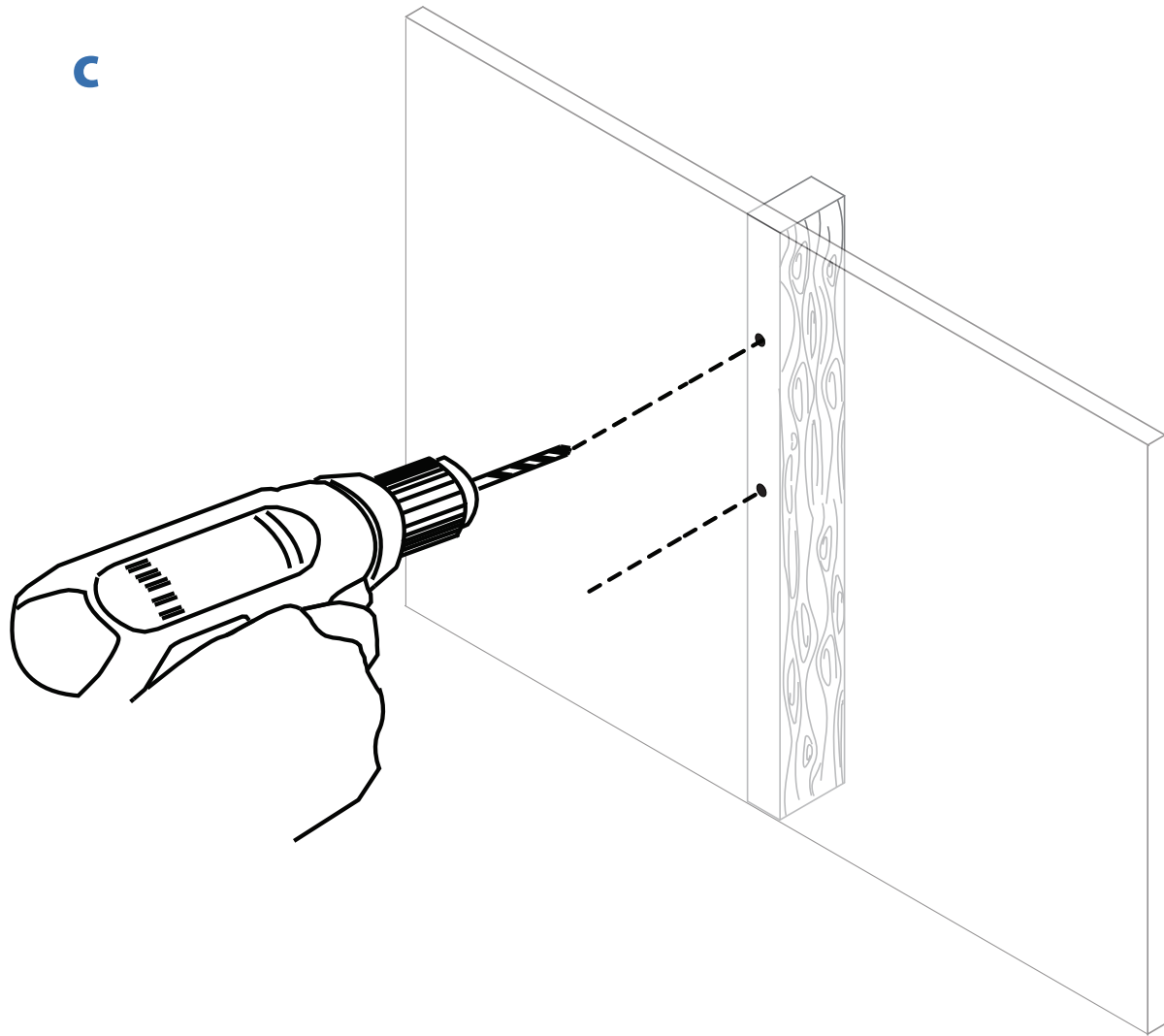
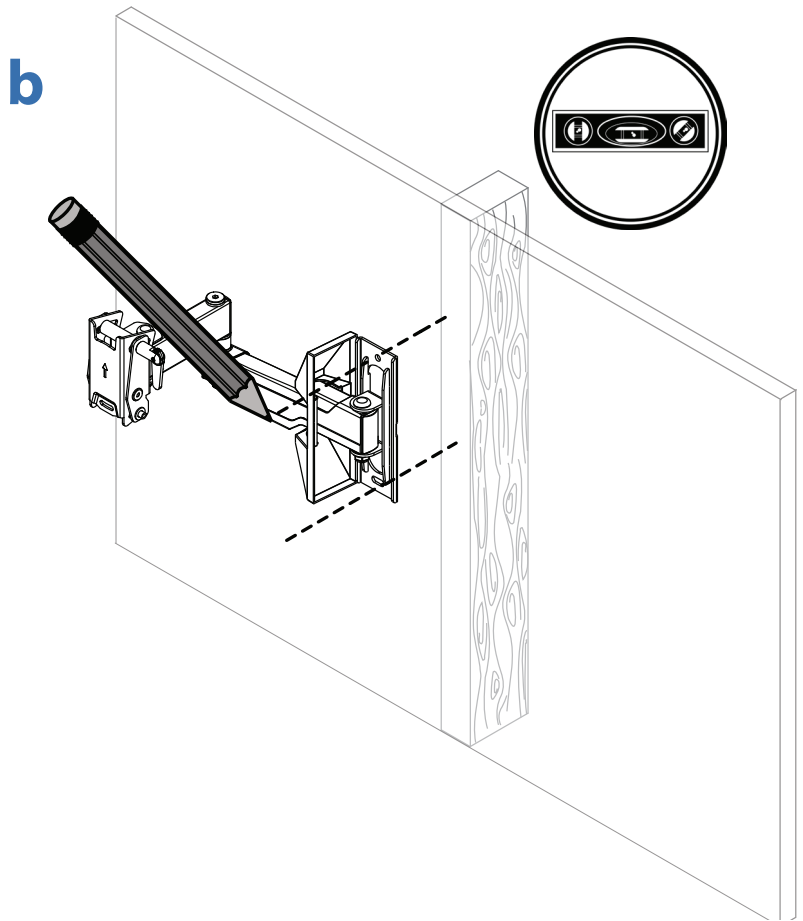
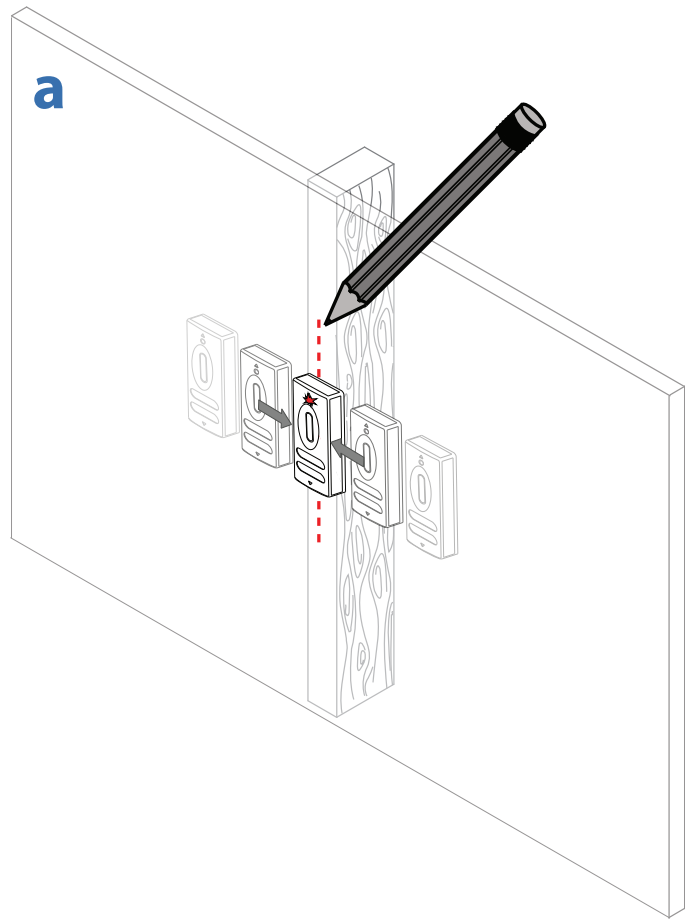

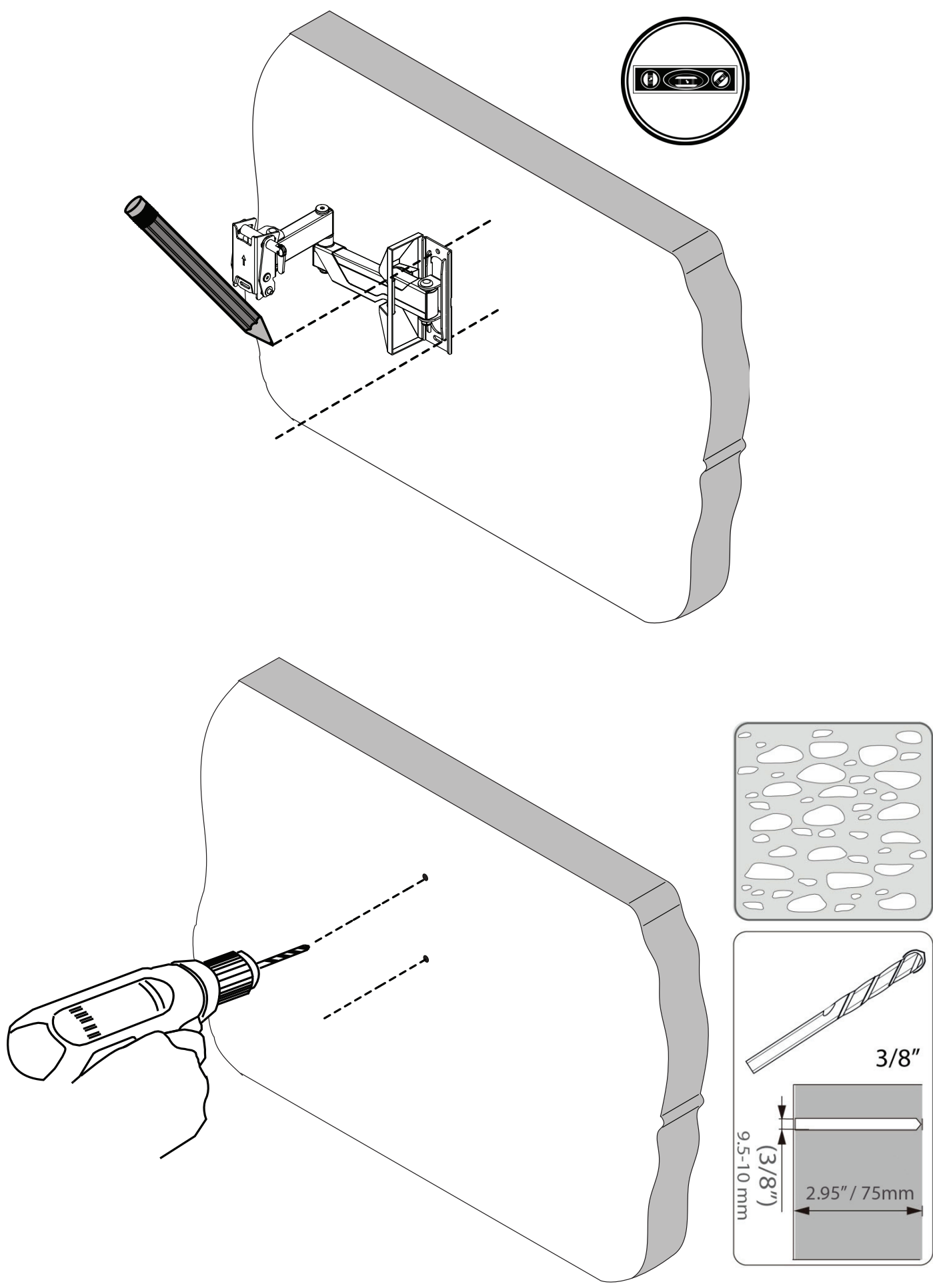

STEP 5 - WOOD STUD INSTALLATION - Установка на деревянной стойке

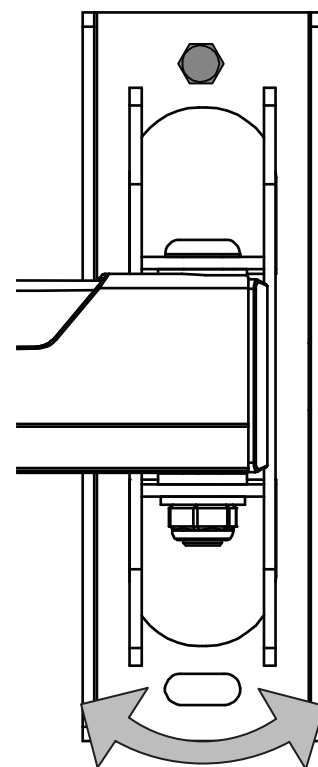
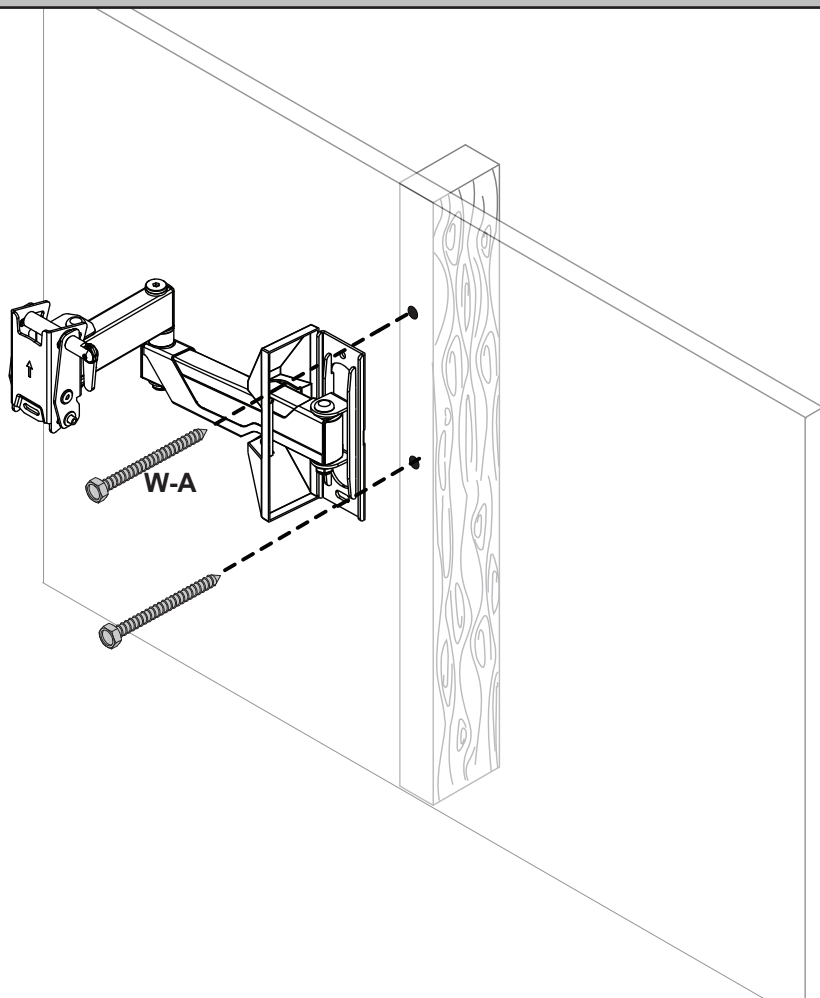
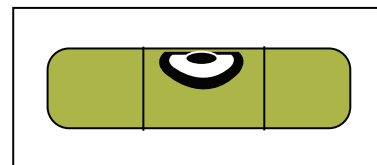

STEP 5 - SOLID WALL INSTALLATION - Установка на бетонной/кирпичной стене

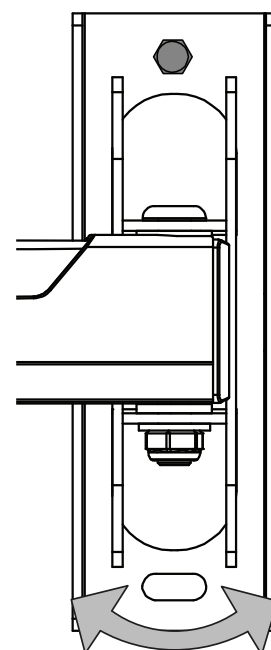
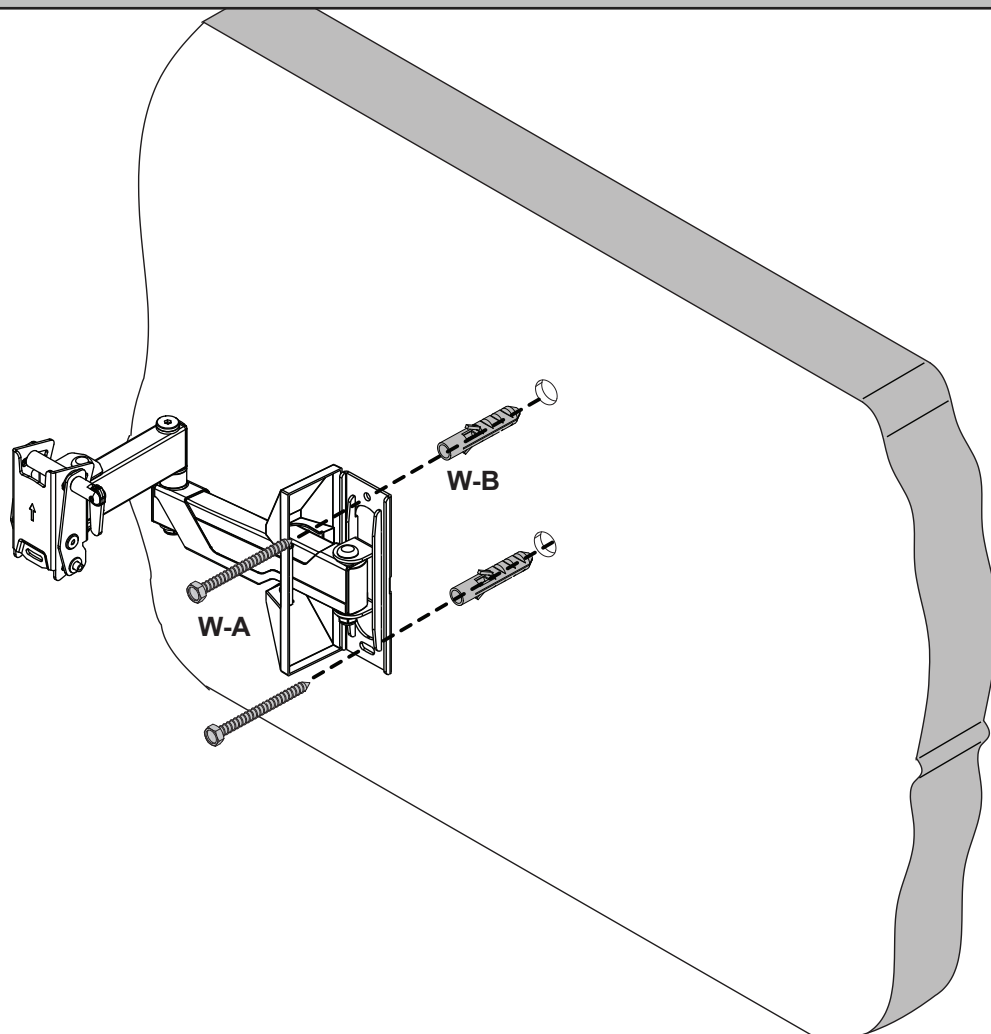
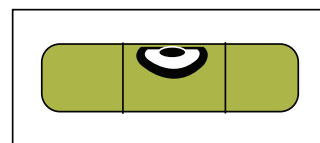

STEP 6 - ATTACH WALL PLATE COVER

Attach covers

Установите крышки

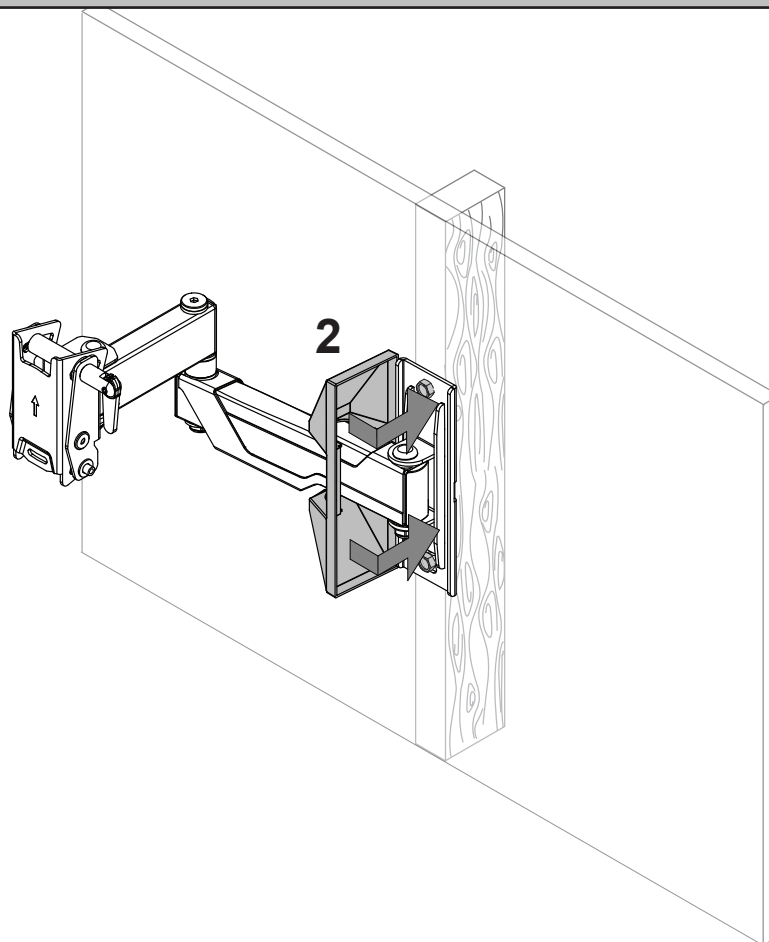

STEP 7 - HANG TV

Hang with monitor attached

Навесьте с установленным монитором.

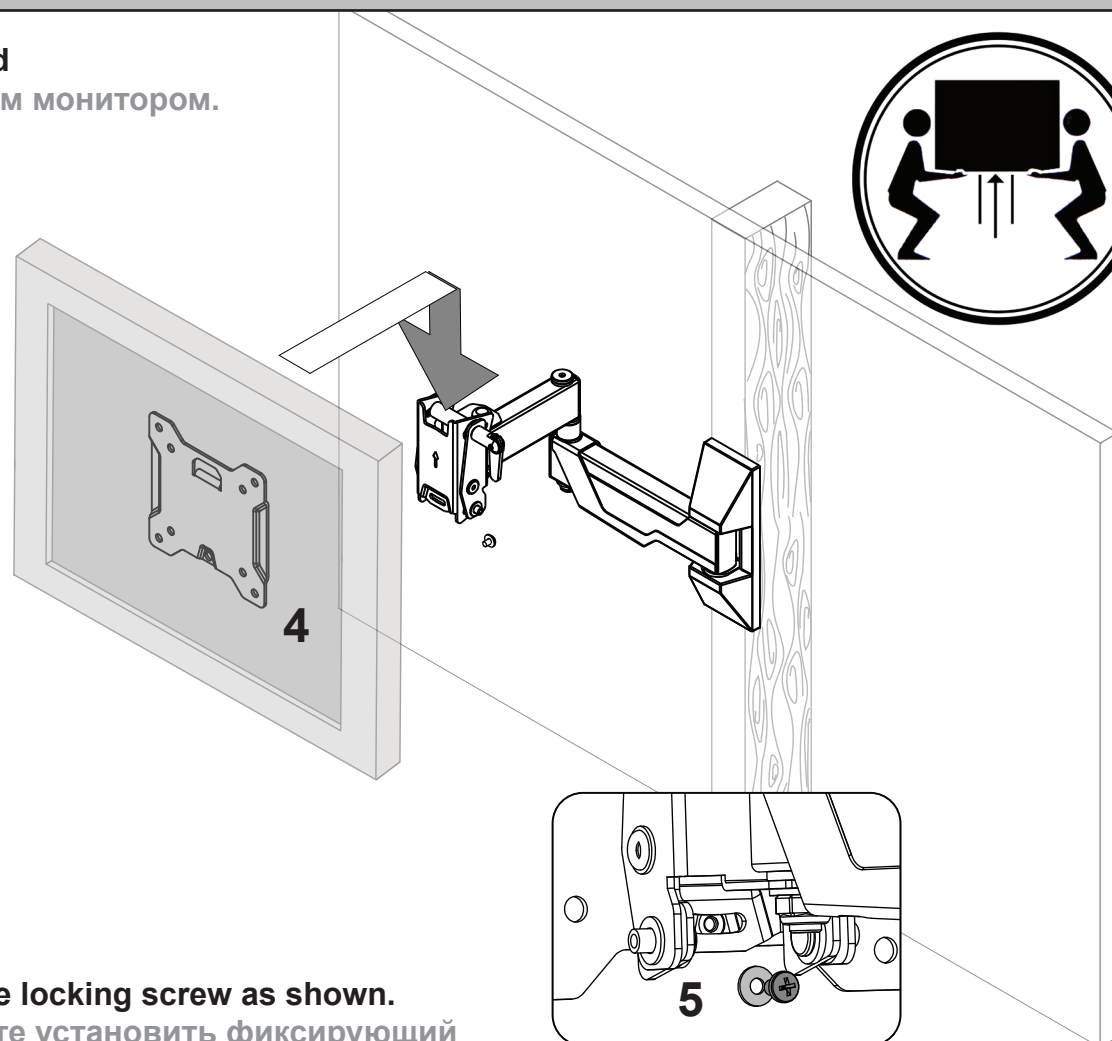

NOTE: Be sure to install the locking screw as shown.

ПРИМЕЧАНИЕ: Не забудьте установить фиксирующий винт, как показано.

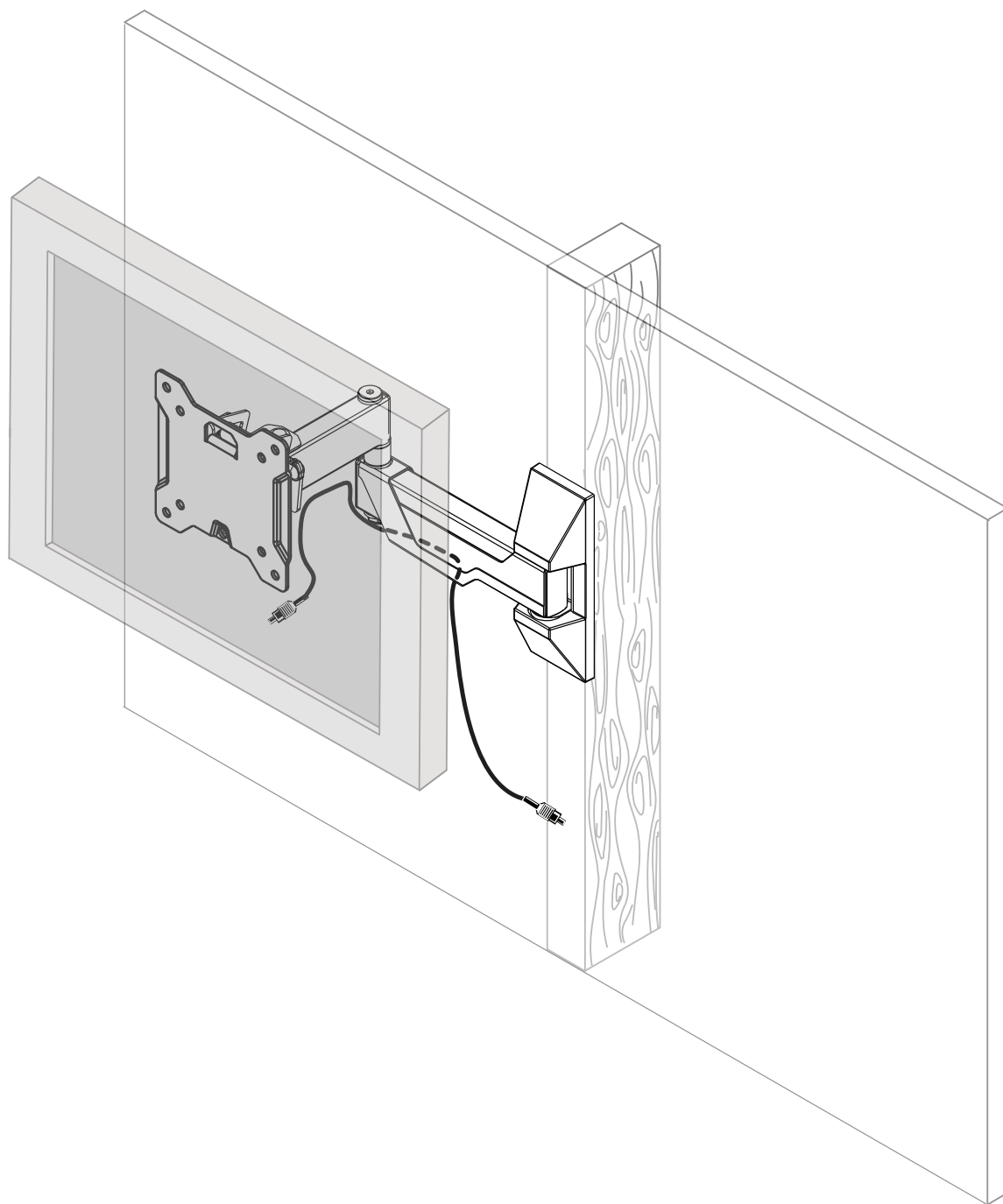

NOTE: To install cables, gently push the cable between the small slit in the cable management cover. Do not pry open cable management covers, doing so may cause breakage.

Примечание: Для установки кабелей, аккуратно вставьте кабель между маленьким разрезом в крышке кабель-канала. Не дергайте крышки кабель-каналов, это может привести к поломке

STEP 9 - ADJUST TILT TENSION

Adjust to Desired Location or Tilt

Отрегулируйте нужное положение и угол наклона

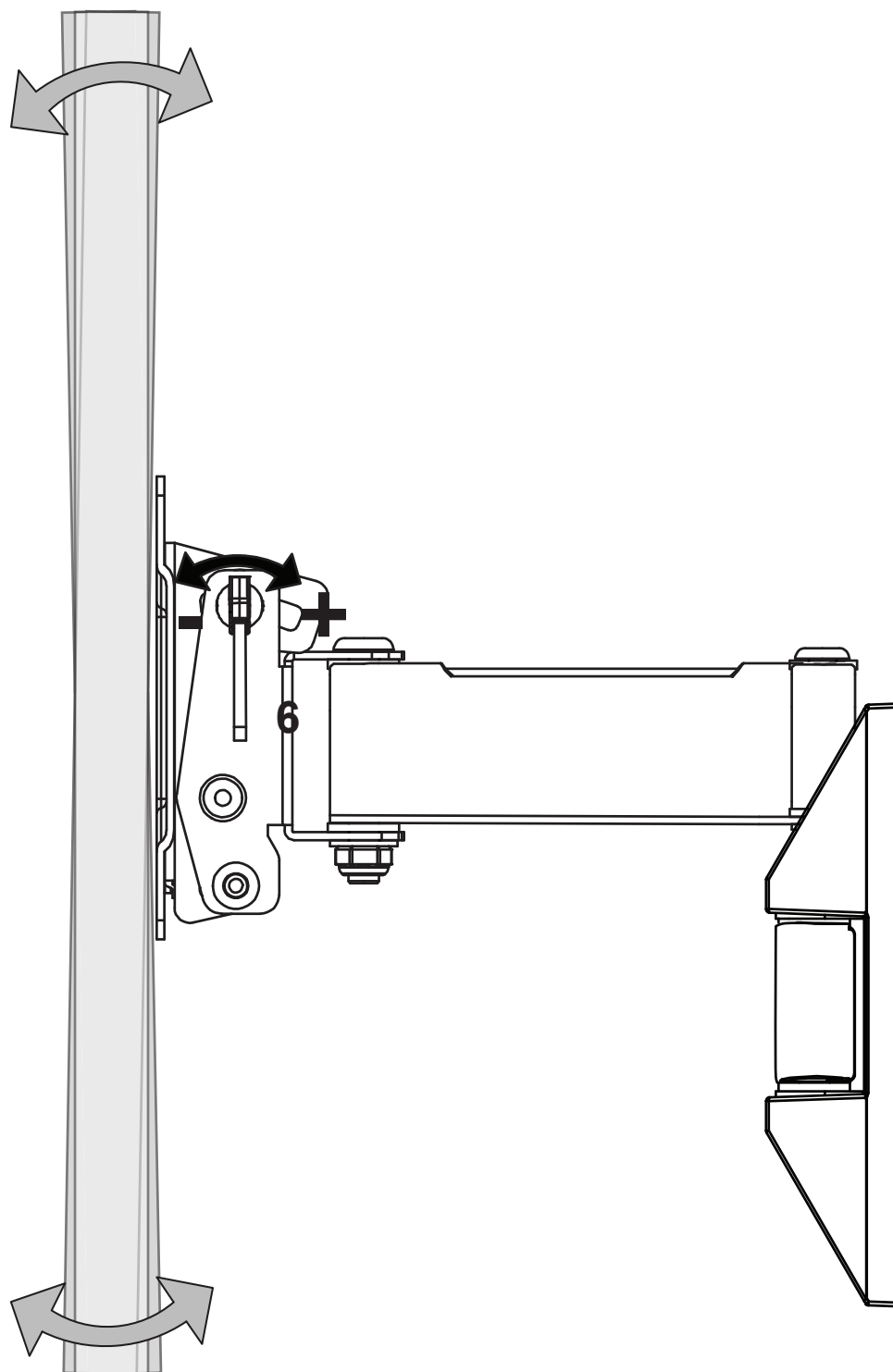

WARRANTY

This warranty applies to US Residents who purchase from an authorized OmniMount Dealer. OmniMount products are covered against defects in materials and workmanship for 5 years. OmniMount will repair or replace the defective component or product, at its sole discretion. Failure to follow product care instructions from OmniMount will result in void of warranty. To obtain warranty service, contact OmniMount customer service at 800.MOUNT.IT (800.668.6848) or info@omnimount.com. You must supply a copy of your original receipt. If your product must be shipped to OmniMount for inspection, you will be responsible for the shipping charges. Replacement product shipped to you will be returned freight pre-paid. OmniMount disclaims any liability for modifications, improper installations, installations over the specified weight range, or failure to follow care instructions provided by OmniMount. To the maximum extent permitted by law, OmniMount disclaims any other warranties, expressed or implied, including warranties of fitness for a particular purpose and warranties of merchantability. OmniMount will not be liable for any damages arising out of the use of, or inability to use, OmniMount products. OmniMount bears no responsibility for incidental or consequential damages. This includes, but is not limited to, any labor charges for the repair of OmniMount products performed by anyone other than OmniMount. This warranty gives you specific legal rights, and you may also have other rights which vary from state to state. Specifications are subject to change without prior notice.

INTERNATIONAL WARRANTY

Notice to customer outside the United States: Please contact the dealer where you purchased this product for details about how to obtain warranty service in your country.

Примечание для клиентов, находящихся за пределами США. Обращайтесь к дилеру, у которого приобретено изделие, чтобы узнать подробную информацию о гарантийном обслуживании в вашей стране.

THANK YOU

Thank you for purchasing an OmniMount product
Благодарим вас за приобретение изделия OmniMount

NEED HELP? PLEASE CALL
НУЖНА ПОМОЩЬ? ЗВОНИТЕ

1-800-MOUNT-IT (1-800-668-6848)

1-800-MOUNT-IT
(USA ONLY)



Ergotron, Inc.
4409 E Baseline Road Ste130
Phoenix, AZ 85042
1-800-MOUNT-IT (1-800-668-6848)
www.omnimount.com

Ergotron Europe
Beeldschermweg 3
3821 AH Amersfoort
The Netherlands
+31 334545600
www.omnimount.com

All trademarks are the property of their respective companies. OmniMount is a registered trademark of Ergotron Inc. © 2013