

## Electro - Acoustic parameters

	ET20	EM 100	EV 130	EV 165	EV 165 L	EV 570	ECX 87	ECX 100	ECX 130	ECX 165	ECX 570	ECX 690
<b>D</b> mm	20	88	110	134	134	143	70	84	110	134	139	171
<b>Xmax</b> mm	-	0,5	3	3	4,5	4,5	2	2	3	3	3	3,5
<b>Re</b> ohm	3,4	3,5	2,9	3,0	3,2	3,2	3,0	3,0	2,9	2,9	3,0	3,2
<b>Fs</b> Hz	1250	164	89	77	62	98	190	121	94	72	83	67
<b>Le</b> mH@1kHz	0,57	0,33	0,52	0,51	0,61	0,48	0,42	0,42	0,52	0,50	0,47	0,62
<b>Le</b> mH@10kHz	0,05	0,07	0,20	0,21	0,24	0,19	0,06	0,06	0,07	0,07	0,06	0,07
<b>Vas</b> lit	-	1,29	4,45	9,5	12,10	7,00	0,60	1,20	4,60	12,30	9,30	25,20
<b>Mms</b> gr	-	3,8	9,0	12,6	15,3	12,5	2,3	6,6	8,0	11,2	12,6	16,8
<b>Cms</b> mm/N	-	0,25	0,35	0,33	0,43	0,20	0,30	0,26	0,36	0,44	0,29	0,34
<b>BL</b> T-m	-	2,39	3,83	4,55	4,60	4,60	2,50	3,80	3,63	4,42	4,43	5,40
<b>Qts</b>	0,53	1,67	0,85	0,77	0,81	1,10	1,00	0,90	0,88	0,66	0,79	0,62
<b>Qes</b>	1,52	2,43	0,99	0,88	0,90	1,20	1,20	0,95	1,03	0,75	0,99	0,77
<b>Qms</b>	0,81	5,33	5,78	6,30	8,20	10,60	5,30	7,50	6,22	5,54	4,00	3,23
<b>Spl</b> dB	91	90	91	93	92	91	87	88	91	93	93	95

energy

# ADVANCED MANUAL

COMP / SYSTEM / COAX

Gentile cliente,  
complimenti per aver acquistato un prodotto HERTZ ENERGY. La vostra soddisfazione è il primo requisito cui devono rispondere i nostri prodotti: la stessa soddisfazione di chiunque voglia vivere l'emozione del car audio.



GLI ALTOPARLANTI HERTZ ENERGY SONO IN GRADO DI CREARE SISTEMI AUDIO AD ALTA POTENZA CHE POSSONO GENERARE ELEVATISSIME PRESSIONI SONORE INDISTORTE. RICORDATE CHE PROLUNGATE ESPOSIZIONI AD UN LIVELLO ECCESSIVO DI PRESSIONE ACUSTICA POSSONO PRODURRE DANNI AL VOSTRO UDITO; UTILIZZATE DUNQUE EQUILIBRIO E BUON SENSO NELL'ASCOLTO.

La sicurezza durante la marcia deve restare sempre al primo posto. In ogni situazione il volume d'ascolto deve avere un livello tale da non coprire i rumori provenienti dall'esterno; dovrete essere in condizione di udire anche quelli del Vostro veicolo per affrontare prontamente situazioni di emergenza.

Per ottenere il massimo delle prestazioni dal Vostro nuovo sistema di altoparlanti Vi consigliamo di seguire attentamente le istruzioni del presente manuale. La realizzazione di un sistema hi-fi car di alto livello richiede una buona conoscenza delle problematiche meccaniche ed elettriche delle autovetture; qualora riteneste di non possedere gli attrezzi necessari o la conoscenza adeguata, non esitate a contattare un installatore specializzato. Un'installazione a regola d'arte Vi assicurerà prestazioni entusiasmanti e coinvolgenti, senza influire sulla sicurezza e l'affidabilità della Vostra autovettura.

Questo manuale è stato redatto per fornire le indicazioni principali e necessarie all'installazione e all'uso del sistema. La varietà delle applicazioni possibili è tuttavia molto ampia; per avere ulteriori informazioni non esitate a contattare il Vostro rivenditore HERTZ o l'assistenza ufficiale HERTZ via mail, scrivendo direttamente agli indirizzi:

Per l'Italia - [supporto.tecnico@elettromedia.it](mailto:supporto.tecnico@elettromedia.it)

Per l'estero - [support@elettromedia.it](mailto:support@elettromedia.it)

## SAFE SOUND

Dear Customer,  
Congratulation for purchasing a product of the **HERTZ ENERGY** line. Your satisfaction is the first requirement that our products must meet: the same satisfaction as that of those who long for the car audio emotion.

**HERTZ ENERGY SPEAKERS CAN CREATE HIGH POWER AUDIO SYSTEMS WHICH MAY GENERATE VERY HIGH UNDISTORTED SOUND PRESSURE. PLEASE REMEMBER THAT LONG EXPOSURE TO AN EXCESSIVELY HIGH SOUND PRESSURE LEVEL MAY DAMAGE YOUR HEARING; THEREFORE , PLEASE USE COMMON SENSE AND PRACTICE SAFE SOUND.**

Safety must be at the first place while driving. In every situation, the listening volume should not cover the noise coming from the outside; You should also be able to hear the noise generated by Your car in order to promptly face any emergency.

In order get the best performance from Your new speakers system we recommend to carefully follow the instructions herein. In order to make a top level car hi-fi system You need to know the car mechanical and electrical issues very well; if You think You lack the required tools or the sufficient knowledge, please contact a specialty installer. A workmanlike installation will ensure You exciting, enthralling performance, without affecting Your car safety and reliability.

This manual has been drawn to provide the main instructions required to install and use the system. However, the range of possible applications is very wide; in order to get further information, please contact Your **HERTZ** dealer or **HERTZ** authorized service sending an e-mail directly to the following email address:

Italy - [supporto.tecnico@elettromedia.it](mailto:supporto.tecnico@elettromedia.it)

Worldwide - [support@elettromedia.it](mailto:support@elettromedia.it)

## INDICE / TABLE OF CONTENTS

Safe Sound / Safe Sound	02
Indice / Table of contents	03
Installazione / Installation	04
Fissaggio Woofer e coassiali / Woofer and coaxial fixing	05
Montaggio EM 100 / EM 100 Mounting	07
Montaggio ET 20 / ET 20 Mounting	08
Regolazione del RHFC / RHFC tuning	10
Crossover / Crossover	11
Collegamenti / Connection	12
Esempi di collegamento / Connection patterns	14
Schema elettrico dei filtri / Electrical diagram	15
Taratura elettroacustica / Electro-acoustic tuning	16
Dimensionamento del cablaggio / Connection cables	17
Specifiche tecniche / Technical specifications	18
Parametri elettroacustici / Electro-acoustic parameters	20

■ **Installazione / Installation**

**DISTANZE CONSIGLIATE / SUGGESTED LENGTH**

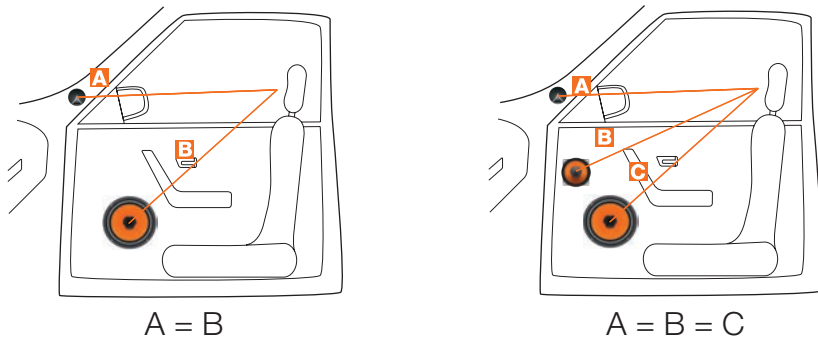

**INCLINAZIONE CONSIGLIATA / SUGGESTED ANGLE**

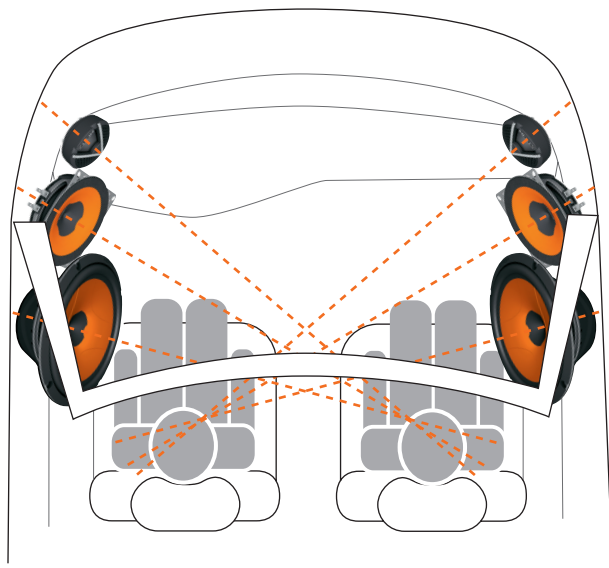

■ **Fissaggio woofer e coassiali / Woofer and coaxial fixing**

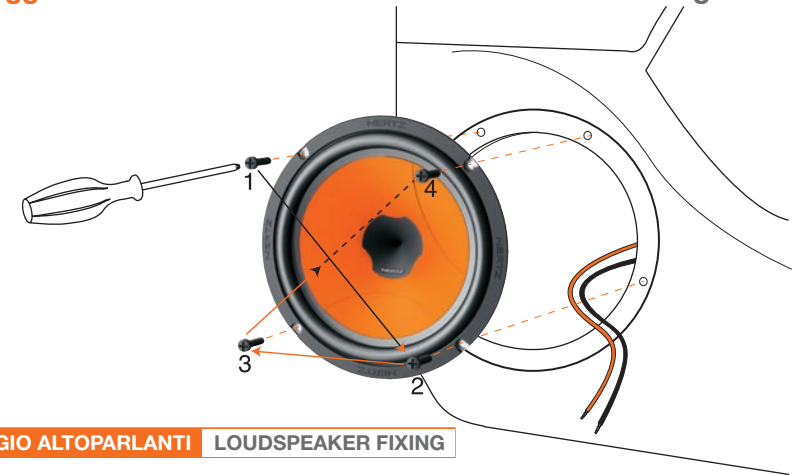

**FISSAGGIO ALTOPARLANTI / LOUSPEAKER FIXING**

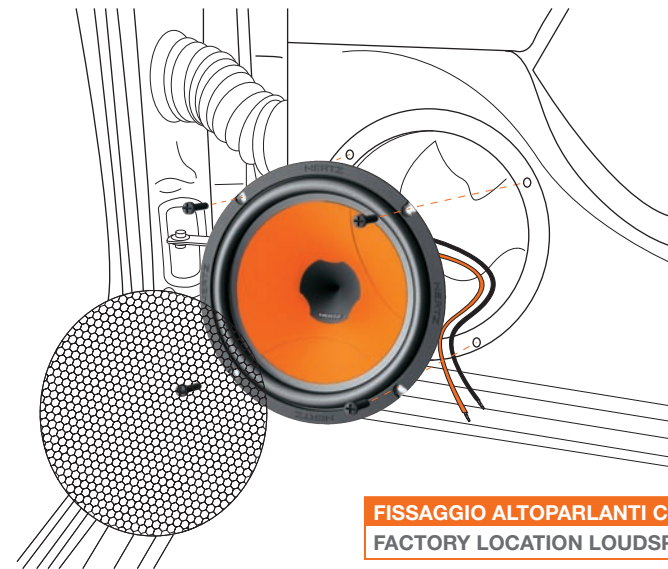

**FISSAGGIO ALTOPARLANTI CON GRIGLIA DI SERIE / FACTORY LOCATION LOUSPEAKER FIXING**

**FISSAGGIO CON GRIGLIA HERTZ HERTZ GRILLE FIXING**



**USARE UNA GUARNIZIONE HOW TO USE GASKET**



**Montaggio EM 100 / EM 100 mounting**

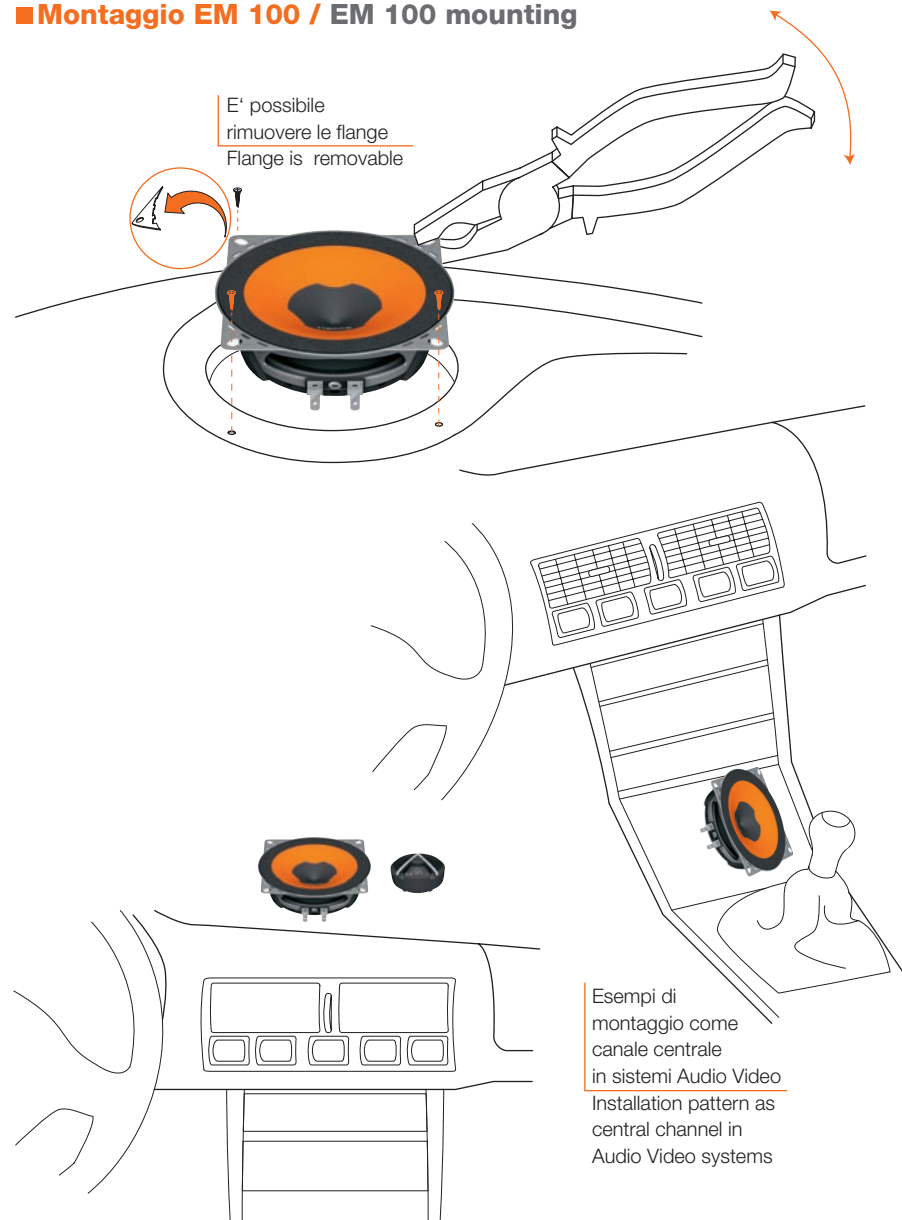

E' possibile  
rimuovere le flange  
Flange is removable

Esempi di  
montaggio come  
canale centrale  
in sistemi Audio Video  
Installation pattern as  
central channel in  
Audio Video systems

■ Montaggio ET 20 / ET 20 mounting

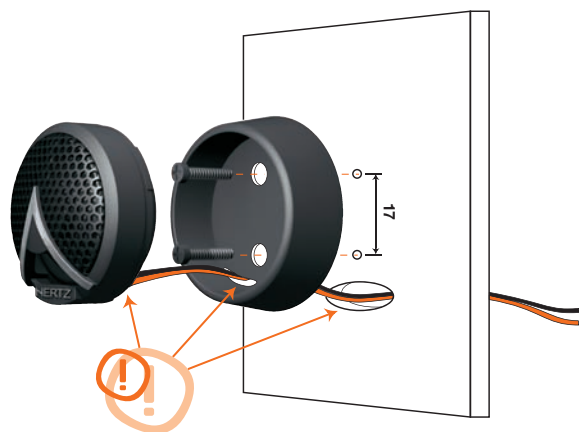

MONTAGGIO A SUPERFICIE | SURFACE MOUNTING

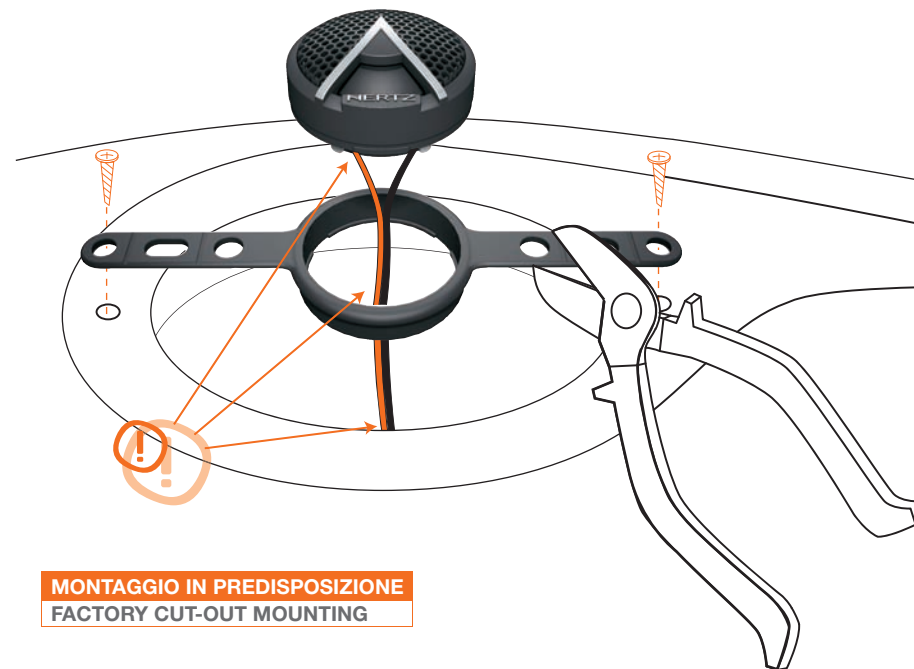

MONTAGGIO IN PREDISPOSIZIONE  
FACTORY CUT-OUT MOUNTING

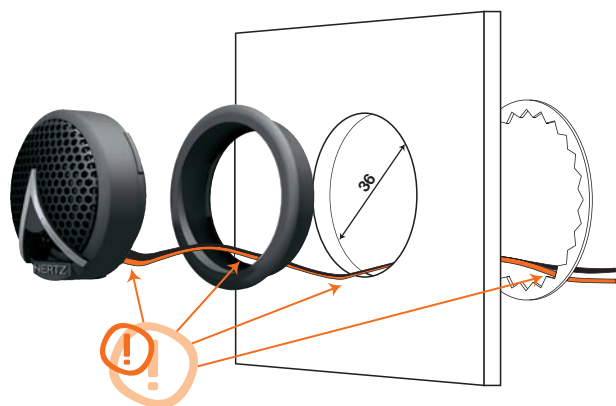

MONTAGGIO A FILO DEL PANNELLO | FLUSH MOUNTING

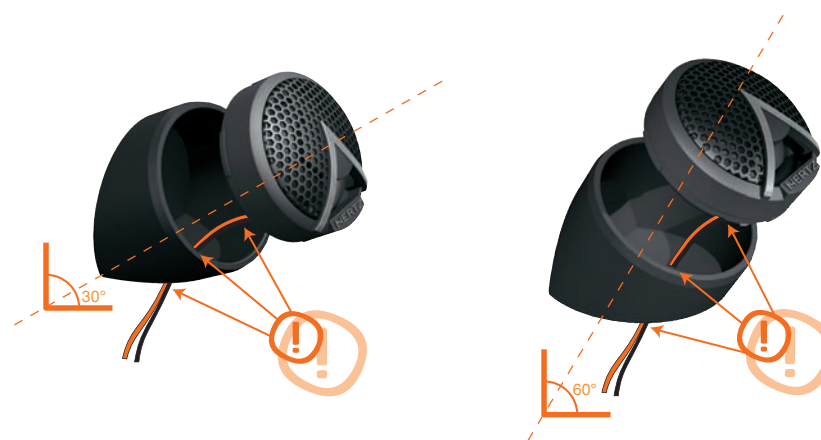

MONTAGGIO CON SUPPORTO INCLINATO | WEDGE MOUNTING



Regolazione del Rotative High Frequency Contour dei Coax HERTZ Energy per l'ottimizzazione delle alte frequenze.  
Rotative High Frequency Contour tuning for high frequency range optimization of HERTZ Energy Coax.

240°

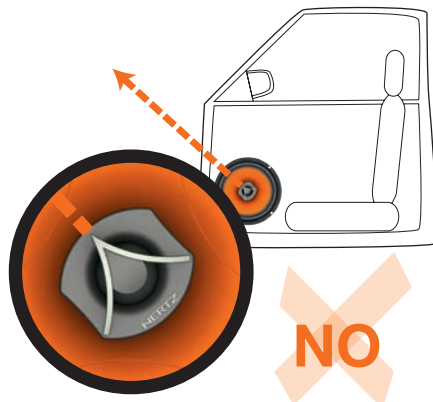
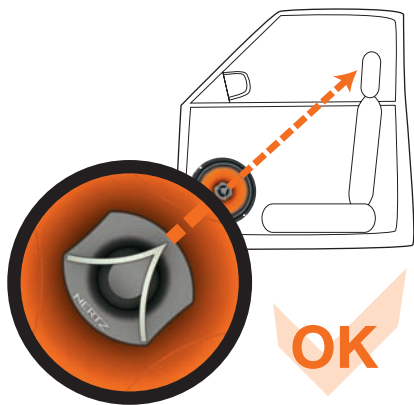

■ Crossover

Rimozione del coperchio  
How to remove the cover



PUSH



PULL

Sistema di fissaggio  
Fixing system



■ CX 200 dimensions

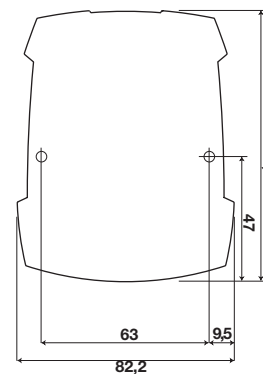

■ CX 300 dimensions

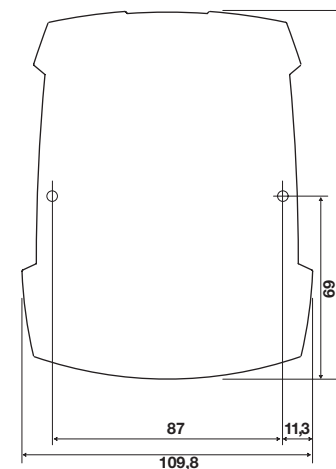

■ Collegamenti / Connection

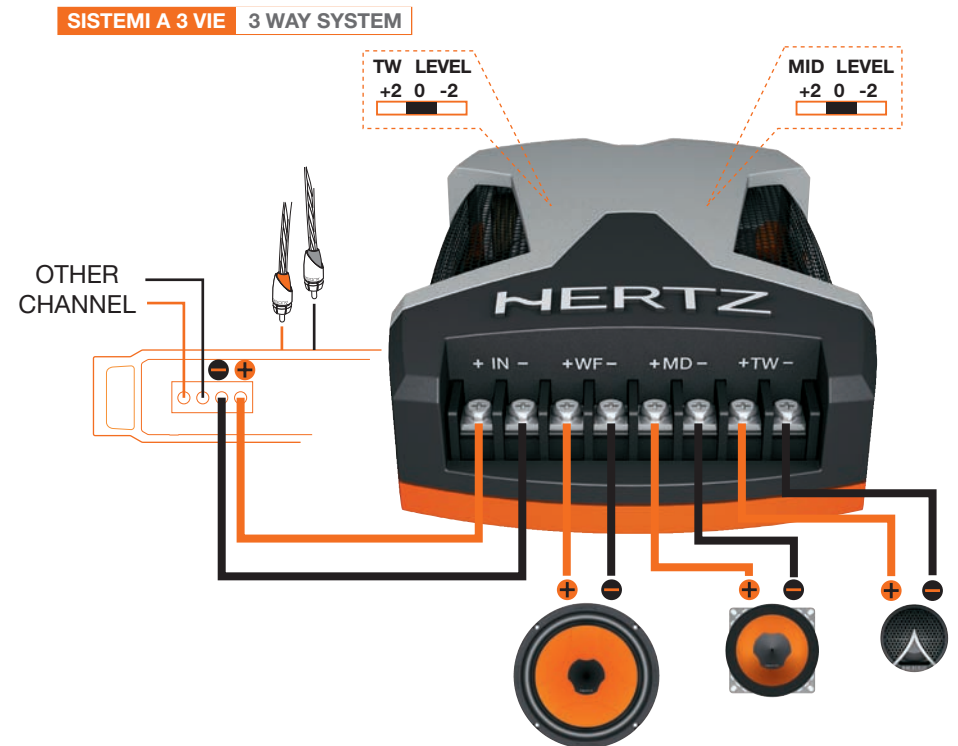
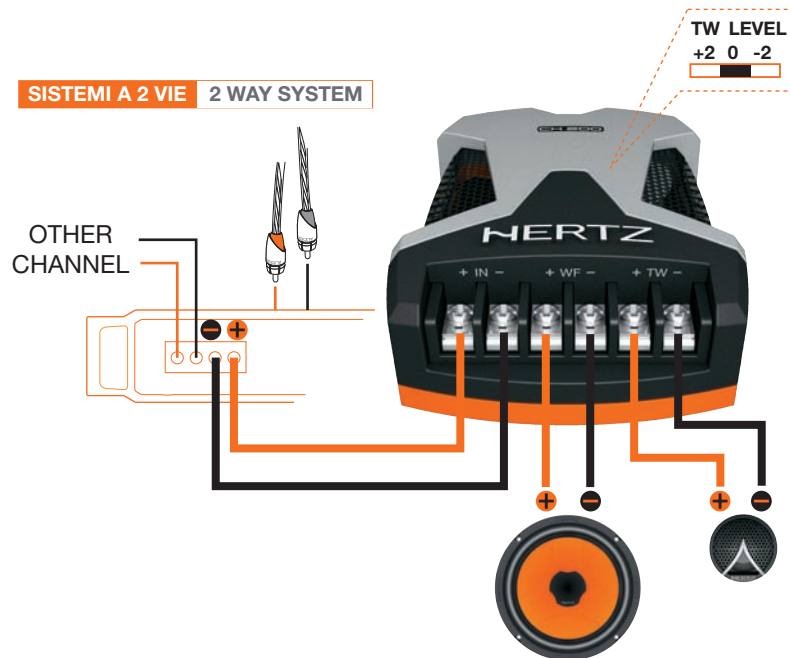
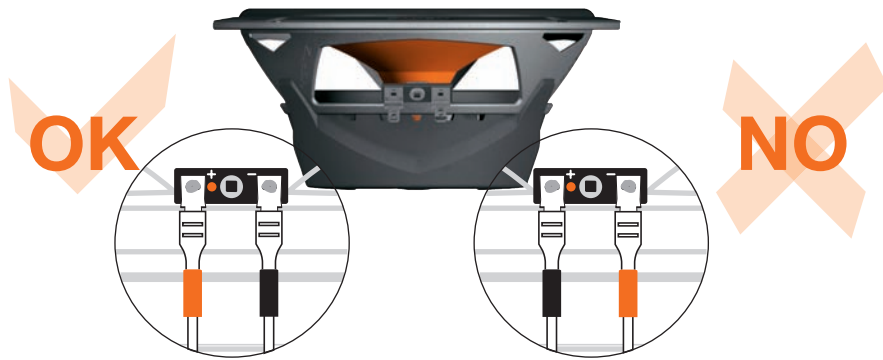

■ Esempi di collegamento / Connection patterns

Singolo, in parallelo o misto.  
One speaker, parallel or mixed

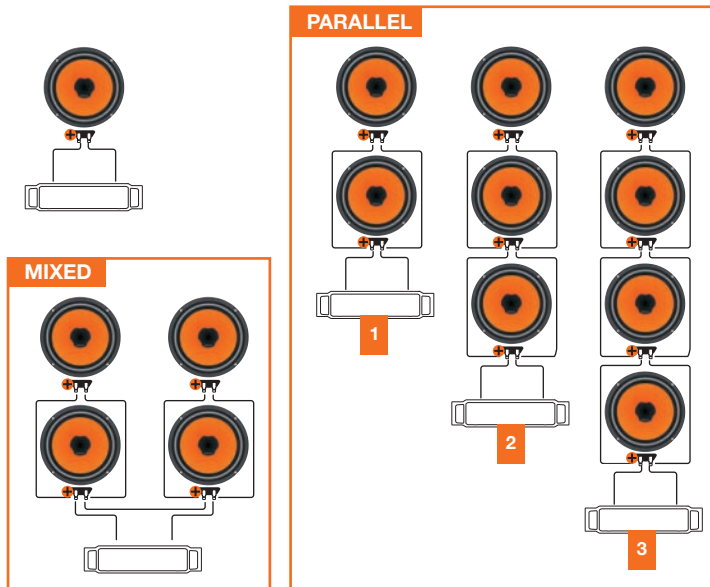

FREE AIR DC RESISTANCE

	ET 20	EM 100	EV 130	EV165	EV 165 L
--	-------	--------	--------	-------	----------

<b>1 Speaker</b>	3,40	3,50	2,90	3,00	3,20
------------------	------	------	------	------	------

<b>Parallel</b>	<b>1</b>	1,70	1,75	1,45	1,50	1,60
	<b>2</b>	1,13	1,17	0,97	1,00	1,07
	<b>3</b>	0,85	0,88	0,73	0,75	0,80

<b>Mixed</b>	3,40	3,50	2,90	3,00	3,20
--------------	------	------	------	------	------

Misure espresse in Ohm / Measure in Ohms

■ Schema elettrico dei filtri / Crossover electrical diagram

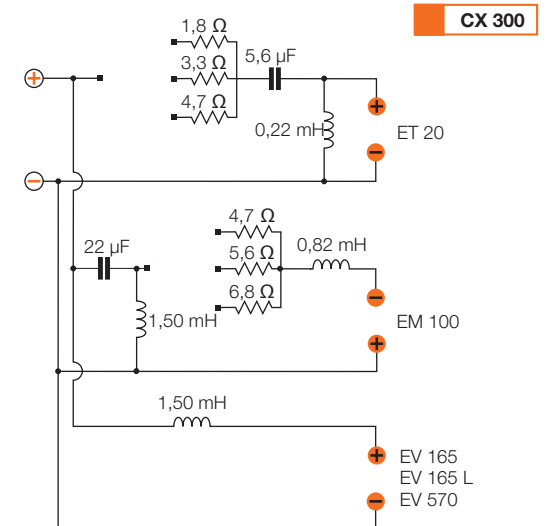
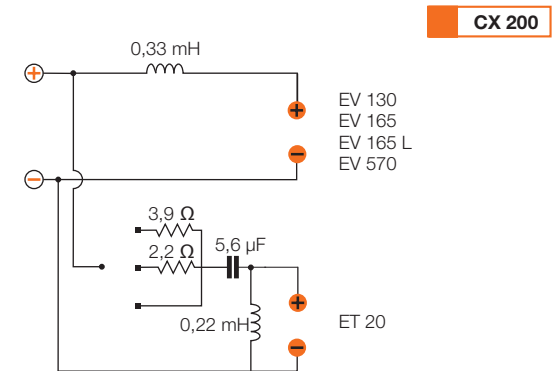



### Taratura Electroacustica / Electro-acoustic tuning

Una volta realizzato il sistema, dedicate alcune attenzioni alla messa a punto dell'impianto e alla taratura dell'amplificazione specifica.

After installing the speakers in your car and checking all connections, you need to spend some time to tune your system and calibrate your amplifier.

#### L - R levels

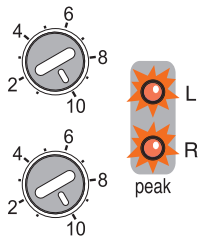

Gain al massimo  
LED sempre accesi  
Amplificatore in distorsione

Maximum gain  
Leds always on  
Distorted amplifier



#### L - R levels

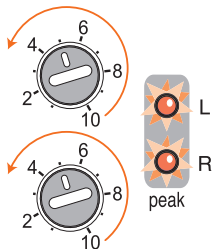

Gain regolati più bassi  
Led che lampeggiano  
Amplificatore in funzionamento lineare

Lower regulated gains  
Flashing leds on signal peaks  
Amplifier in linear functioning area

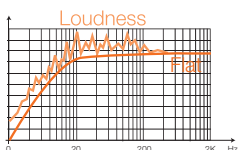

Evitate l'utilizzo del loudness o di equalizzazioni in gamma bassa.  
Avoid using loudness or excessive equalization.

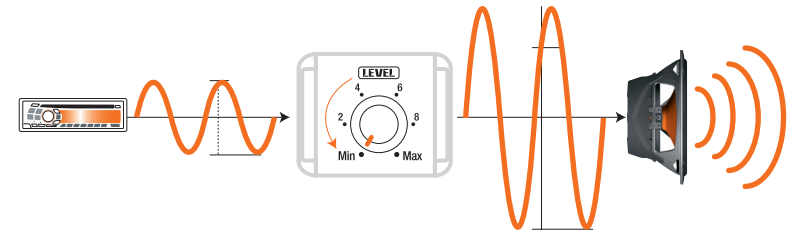

Regolate il livello del gain dell'amplificatore in modo da sfruttare tutta la potenza indistorta dell'amplificatore.

Adjust the input sensitivity control tuning the amplifier input section according to the signal which comes from the source; this way you exploit the amplifier maximum power without distortion.

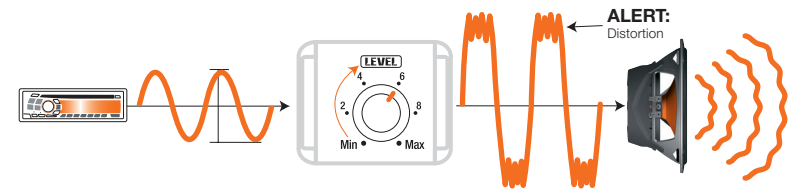

### Dimensionamento del cablaggio / Choosing your cables

Il cablaggio di potenza riveste un ruolo importante poichè influenza direttamente il fattore di smorzamento del sistema e la qualità del suono; nella tabella allegata potete trovare una indicazione della sezione del cavo, consigliata in funzione della lunghezza e della potenza applicata.

Power cables are extremely important since they directly affect the system damping factor and sound quality; in the table below we show cable diameter, which we recommend according to length and applied power.

La tavola si riferisce alla potenza continua su un carico di 4 ohm. Qualora il carico scenda, si dovranno aumentare proporzionalmente le dimensioni del cavo.

The table refers to continuous power with 4 Ohm load. If load decreases, the cable size needs to be proportionally increased.

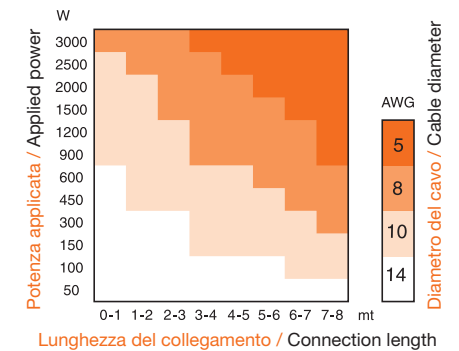

TECHNICAL SPECIFICATIONS

Component	Size	mm	peak	continuous program	ohm	Hz	dB/SPL	mm	mm
ET 20	Tweeter	20 (3/4")	100	100W@3,5k Hz12dB Oct.	4	2k - 23k	91	33,5	36
EM 100	Cone Midrange	100 (4")	150	75	4	400 - 14,5k	90	102	95
EV 130	Woofers	130 (5" 1/4)	100	50	4	65 - 8k	91	130	120
EV 165	Woofers	165 (6" 1/2)	140	70	4	60 - 8k	93	165	145
EV 165 L	Woofers	165 (6" 1/2)	140	70	4	50 - 6k	92	165	145
ESK 130	2 Way System	Tweeter 20 (3/4") Woofers 130 (5" 1/4)	150	75	4	65 - 23k	91	130	120
ESK 165	2 Way System	Tweeter 20 (3/4") Woofers 165 (6" 1/2)	200	100	4	60 - 23k	93	165	145
ESK 165 L	2 Way System	Tweeter 20 (3/4") Woofers 165 (6" 1/2)	200	100	4	50 - 23k	92	165	145
ESK 570	2 Way System	Tweeter 20 (3/4") Woofers (5x7")	200	100	4	60 - 23k	93	195	184
ESK 163 L	3 Way System	Tweeter 20 (3/4") Midrange 100 (4") Woofers 165 (6" 1/2)	250	125	4	50 - 23k	92	165	145
ECX 87	2 W Coaxial	Tweeter 15 (19/32") Woofers 87 (3" 1/2)	60	30	4	120 - 21k	87	87	80
ECX 100	2 W Coaxial	Tweeter 20 (3/4") Woofers 100 (4")	80	40	4	70 - 23k	88	102	95
ECX 130	2 W Coaxial	Tweeter 20 (3/4") Woofers 130 (5" 1/4)	100	50	4	65 - 23k	91	130	120
ECX 165	2 W Coaxial	Tweeter 20 (3/4") Woofers 165 (6" 1/2)	140	70	4	60 - 23k	93	165	145
ECX 570	2 W Coaxial	Tweeter 20 (3/4") Woofers (5x7")	140	70	4	60 - 23k	93	195	184
ECX 690	3 W Coaxial	Supertweeter 15 (19/32") Tweeter 40 (1,5") Woofers (6x9")	200	100	4	40 - 23k	95	237	225

Magnet size	Total depth	Mounting depth	Weight of one component	Voice coil diameter	Magnet	Cone / Dome
23,5	19	11	0,033	20	Neodymium REN	Tetolon
58	33	28	0,236	25	Neodymium REN	V-Cone, treated paper
80	60	56	0,754	25	High density flux ferrite	V-Cone, treated paper
85	72	66	0,911	25	High density flux ferrite	V-Cone, treated paper
85	72	66	0,920	25	High density flux ferrite	V-Cone non pressed paper
80	60	56	0,754	25		
85	72	66	0,911	25		
85	72	66	0,920	25		
85	72	65	0,948	25		
85	72	66	0,920	25		
60	46	35	0,317	25	High density flux ferrite	Water-repellent paper
75	60	46	0,573	25	High density flux ferrite	RHFC on treated paper
80	73	56	0,794	25	High density flux ferrite	RHFC on treated paper
85	77	66	0,954	25	High density flux ferrite	RHFC on treated paper
85	77	65	0,988	25	High density flux ferrite	RHFC on treated paper
100	98	78	1,420	25	High density flux ferrite	Water-repellent paper

