

TANNOY®

MERCURY Vi

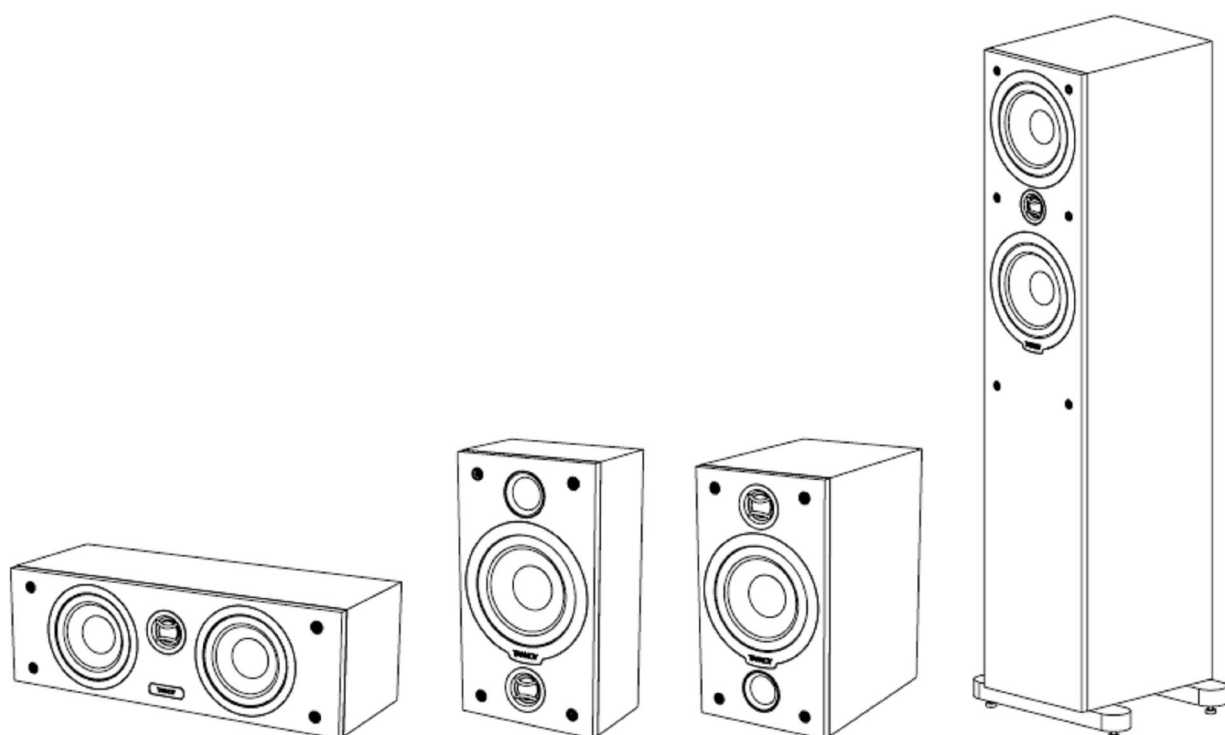

MERCURY Vi

Tannoy

Tannoy

www.tannoy.com

1

Tannoy,

(~24)

Tannoy

« »,

« »

(),

()

90-100%,

60-70%

Mercury V4i:

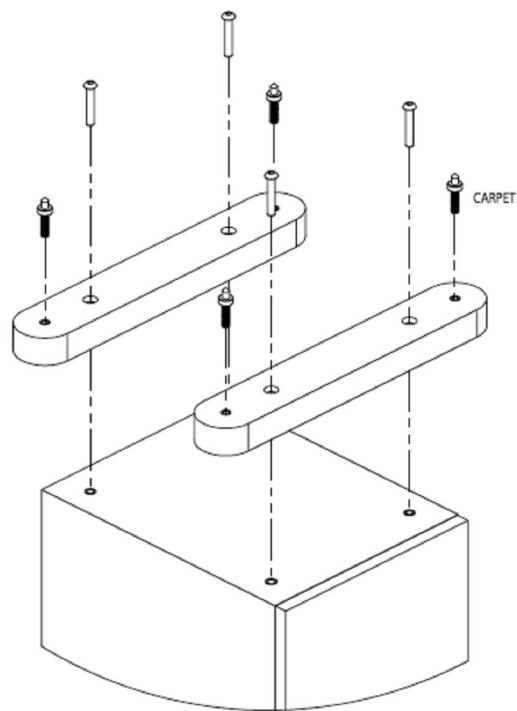

Mercury V1i, VCi, VRi:

(
«
V i V1i
2
VRi «M5».

Mercury V1i, VCi VRi:

(Plus) («+»)

(Minus) («-»)

(Plus) («+»)

(Minus) («-»)

(, CD)

(,)

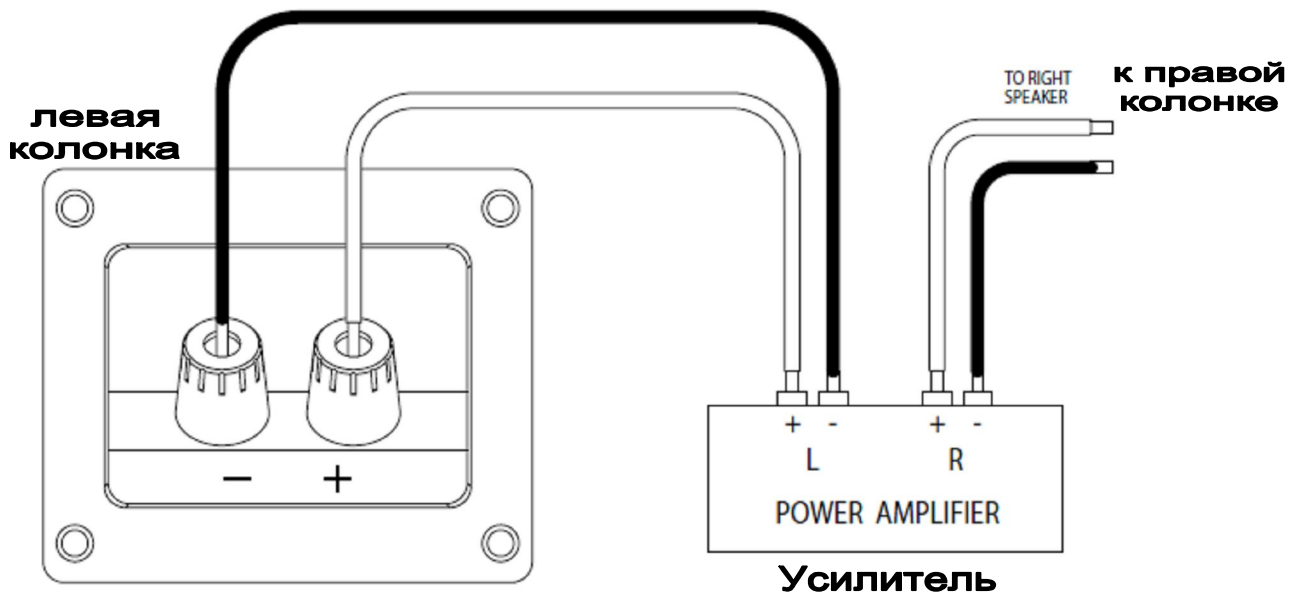

Mercury V4i:

1. - Single Wire - 2
- HF,+HF.

**!!! переключки
прикручены**

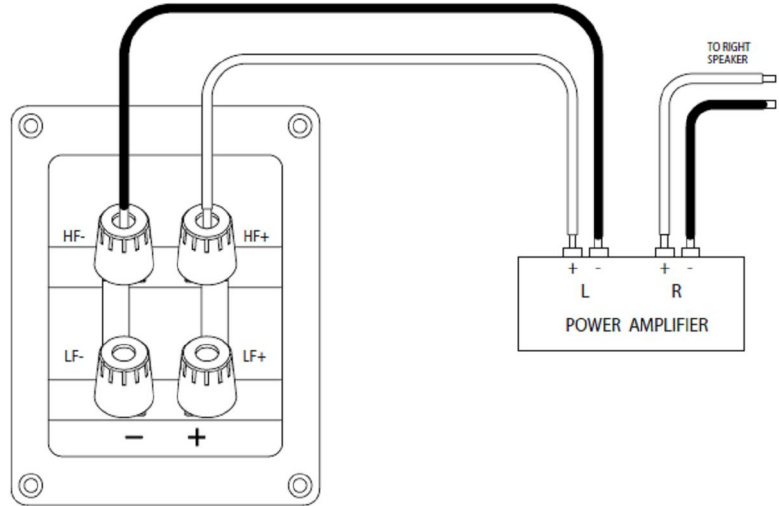

2 . Bi-Wire, 2- (,) ,
 4 ').
 : Right LF (), Left LF (), Left HF ().
 Right HF (), Right HF ().
 2- bi-wire / bi-amp
 + Left LF () + Left HF ()
 +
 - Left LF () - Left HF ()
 2 : - Left HF + Left HF
 - Left LF + Left LF
 - Right LF + Right LF : - Right HF + Right HF

**!!! переключки
сняты**

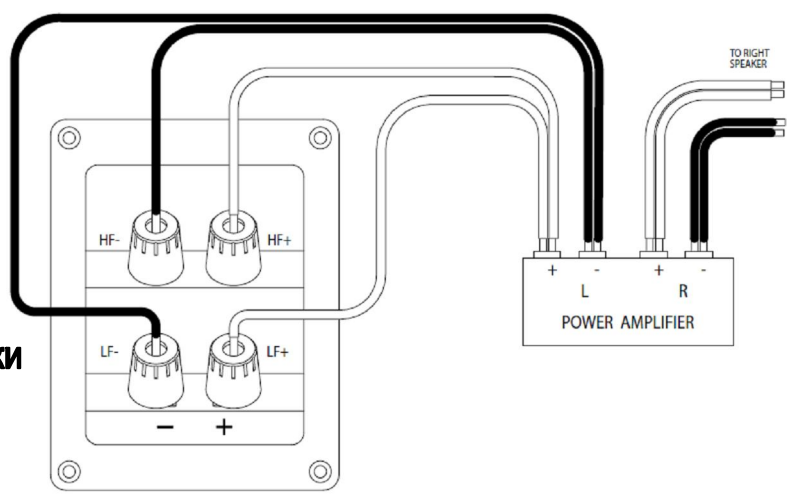

2 . Bi-Amp:

2

() CD

2

!!! переключки
сняты

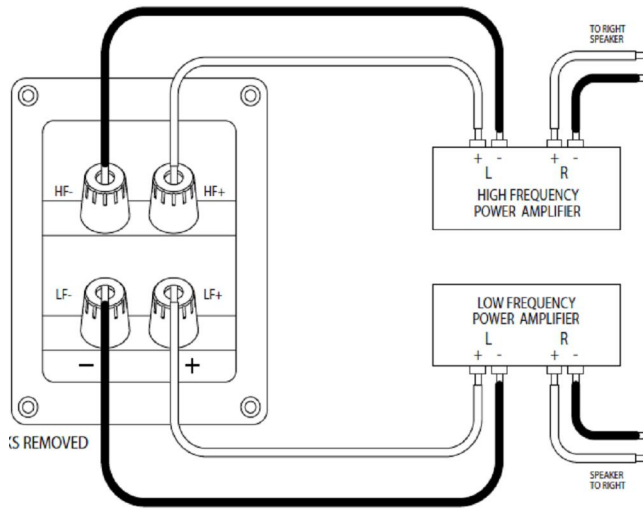

Surround back.

(

).

1

).

(0.4-0.5

V4i

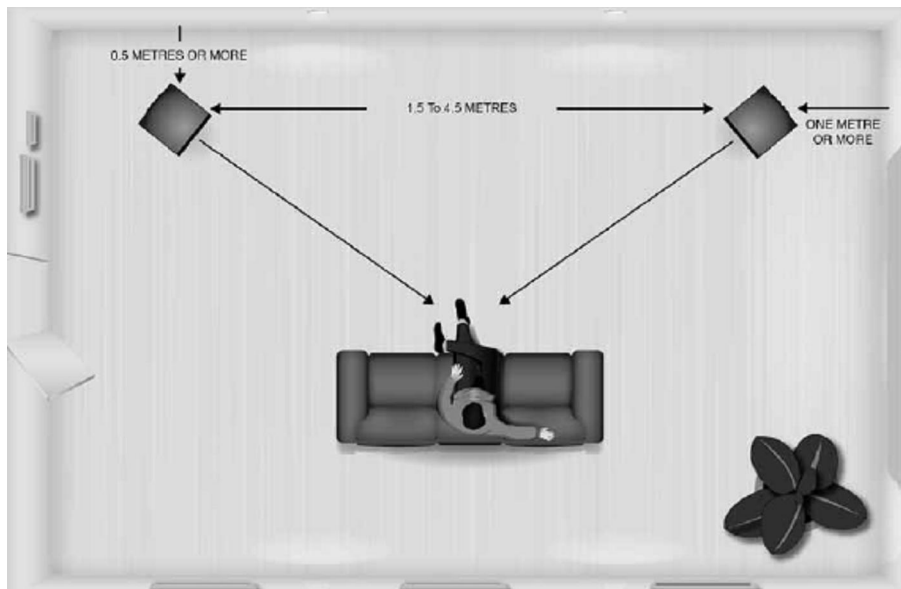

()

Mercury Vi Home Theatre 5.1:

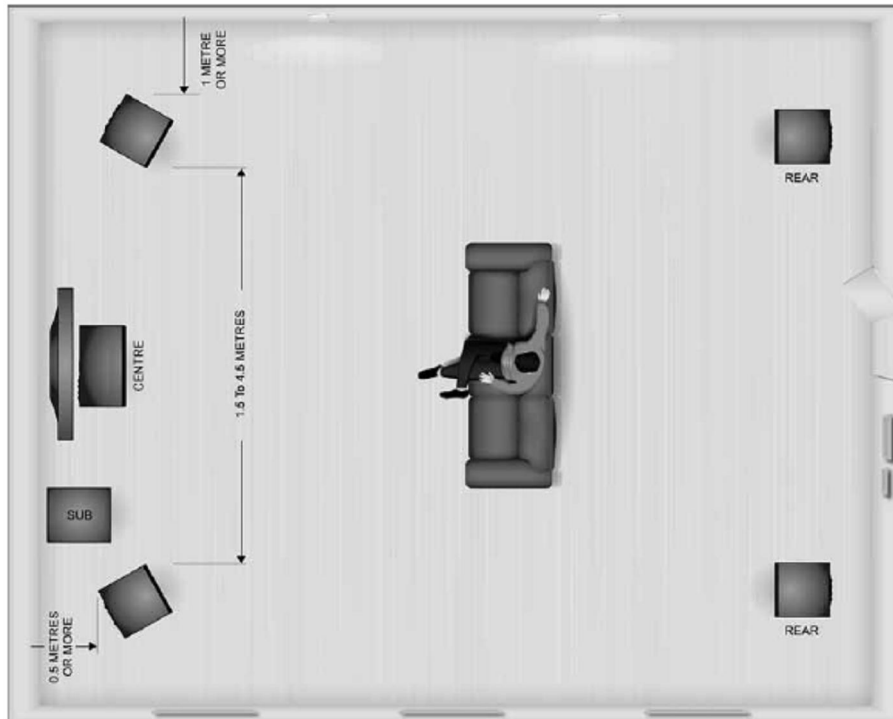

V4i, VCi, V1i

V4i

V1i

VCi

V1i

VRi

1.5-2

Mercury

Tannoy TS2.10

TS2.12.

Mercury V i:

: 10-90 (RMS),

: 70 (RMS),

: 90

: 8

: 67 -53 (-6),

: 25

: 2 100

(2),

() : 140 430 170

: 4.9

Mercury V4i:

: 10-140 (RMS),
 : 100 (RMS),
 : 200 ,
 : 91 ,
 : 8 ,
 : 32 -53 (-6) ,
 : 25 ,
 : 2 152 ,
 : 2.6 ,
 : 4- « - » ,
 : MDF, 18 , 15 ,
 () . : 996 204 281 ,
 : 38.5 ,
 : 14.7 .
 : Dark walnut, Sugar maple (,).

Mercury V1i:

: 10-70 (RMS),
 : 50 (RMS),
 : 100 ,
 : 86 ,
 : 8 ,
 : 45 -53 (-6) ,
 : 25 ,
 : 130 ,
 : 3.2 ,
 : 4- « - » ,
 : MDF, 18 , 15 ,
 () . : 300 170 255 ,
 : 4.5 .

Mercury VRi:

: 10-60 (RMS),
 : 40 (RMS),
 : 80 ,
 : 86 ,
 : 8 ,
 : 57 -53 (-6) ,
 : 25 ,
 : 130 ,
 : 3.2 ,
 : 4- « - » ,
 : MDF, 18 , 15 ,
 () . : 300 170 122 ,
 : 2.6 .