

Blu-ray Disc Player

BD-S473

*Инструкция по эксплуатации
Owner's Manual*

Русский

English

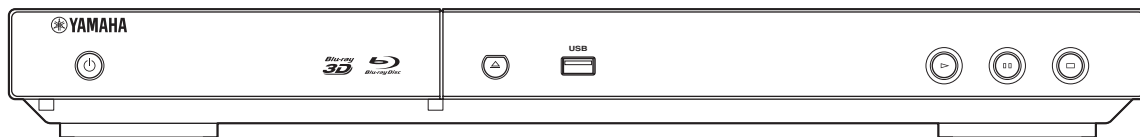

Предупреждение: внимательно прочитайте это перед использованием аппарата.

- 1 Для обеспечения наилучшего результата, пожалуйста, внимательно прочитайте данную инструкцию. Храните ее в безопасном месте для будущих справок.
- 2 Данный аппарат следует устанавливать в хорошо проветриваемом, прохладном, сухом месте, вдали от прямого воздействия солнечных лучей, источников тепла, вибрации, пыли, влаги и/или холода. Для надлежащей вентиляции необходимо обеспечить следующие минимальные просветы.
Сверху: 10 см
Сзади: 10 см
По сторонам: 10 см
- 3 Во избежание шумов и помех, данный аппарат следует размещать на некотором расстоянии от других электрических приборов, двигателей или трансформаторов.
- 4 Во избежание накопления влаги внутри данного аппарата, что может вызвать электрошок, пожар, привести к поломке данного аппарата, и/или представлять телесное повреждение, не следует размещать данный аппарат в среде, подверженной резким изменениям температуры с холодной на жаркую, или в среде с повышенной влажностью (например, в комнате с увлажнителем воздуха).
- 5 Не устанавливайте данный аппарат в местах, где есть риск падения других посторонних объектов на данный аппарат и/или где данный аппарат может подвергнуться попаданию капель брызг жидкостей. На крышке данного аппарата, не следует располагать:
 - Другие компоненты, так как это может привести к поломке и/или обесцвечиванию поверхности данного аппарата.
 - Горящие объекты (например, свечи), так как это может привести к пожару, поломке данного аппарата и/или представлять телесное повреждение.
 - Емкости с жидкостями, так как при их падении жидкости могут вызвать поражение пользователя электрическим током и/или привести к поломке данного аппарата.
- 6 Во избежание прерывания охлаждения данного аппарата, не следует покрывать данный аппарат газетой, скатертью, занавеской и т.д. Повышение температуры внутри данного аппарата может привести к пожару, поломке данного аппарата и/или представлять телесное повреждение.
- 7 Пока все соединения не завершены, не следует подключать данный аппарат к розетке.
- 8 Не используйте данный аппарат, установив его верхней стороной вниз. Это может привести к перегреву и возможной поломке.
- 9 Не применяйте силу по отношению к переключателям, ручкам и/или проводам.
- 10 При отсоединении силового кабеля питания от розетки, вытягивайте его, удерживая за вилку; ни в коем случае не тяните кабель.
- 11 Не применяйте различные химические составы для очистки данного аппарата; это может привести к разрушению покрывающего слоя. Используйте чистую сухую ткань.
- 12 Используйте данный аппарат с соблюдением напряжения, указанном на данном аппарате. Использование данного аппарата при более высоком напряжении, превышающем указанное, является опасным, и может стать причиной пожара, поломки данного аппарата, и/или представлять телесное повреждение. Yamaha не несет ответственности за любую поломку или ущерб вследствие использования данного аппарата при напряжении, не соответствующем указанному напряжению.
- 13 Во избежание поломки от молнии, отключите силовой кабель питания от розетки во время электрической бури.
- 14 Не пробуйте модифицировать или починить данный аппарат. При необходимости свяжитесь с квалифицированным сервисным центром Yamaha. Корпус аппарата не должен открываться ни в коем случае.
- 15 Если вы не собираетесь использовать данный аппарат в течение продолжительного промежутка времени (например, во время отпуска), отключите силовой кабель переменного тока от розетки.
- 16 Перед тем как прийти к заключению о поломке данного аппарата, обязательно изучите раздел “Устранение неисправностей”, описывающий часто встречающиеся ошибки во время использования.
- 17 Перед перемещением данного аппарата, установите данный аппарат в режим ожидания нажатием кнопки , и отсоедините силовой кабель переменного тока от розетки.
- 18 При внезапном изменении окружающей температуры образовывается конденсация. Отсоедините силовой кабель питания от сети и не пользуйтесь аппаратом.
- 19 Аппарат может нагреваться при его продолжительном использовании. Отключите питание, затем дайте аппарату остыть.
- 20 Данный аппарат следует устанавливать возле розетки переменного тока, куда можно свободно протянуть силовой кабель.
- 21 Батарейки не должны подвергаться нагреву от солнечных лучей, огня или похожих источников.

Данный аппарат считается не отключенным от источника переменного тока все то время, пока он подключен к розетке, даже если данный аппарат находится в выключенном положении через . Данное положение является режимом ожидания. В этом режиме электропотребление данного аппарата снижается до минимума.

ПРЕДУПРЕЖДЕНИЕ
ВО ИЗБЕЖАНИЕ ПОЖАРА ИЛИ УДАРА ЭЛЕКТРИЧЕСКИМ ТОКОМ НЕ ПОДВЕРГАЙТЕ ДАННЫЙ АППАРАТ ВОЗДЕЙСТВИЯМ ДОЖДЯ ИЛИ ВЛАГИ.

Лазерный компонент данного изделия может выделять радиацию, превышающую ограниченный уровень радиации для Класса 1.

1. Введение

Возможности этого проигрывателя	2
Прилагаемые компоненты	2
О дисках и файлах	3
Типы дисков/файлов, которые можно использовать с этим проигрывателем.....	3
Загрузка диска.....	3
Меры предосторожности при обращении с диском	4
Примечание по просмотру видеоизображений в формате 3D	4
Технология Cinavia.....	4
Органы управления и функции	5
Передняя панель	5
Задняя панель	5
Пульт дистанционного управления	6

2. Подключение

Подключение HDMI	10
Подключение к разьему HDMI	10
Подключение для воспроизведения дисков Blu-ray 3D.....	10
Сетевое и USB-подключение	11
Подключение к разьему NETWORK.....	11
Подключение к разьему USB	11

3. Воспроизведение

Начальные установки/	
Простая установка	12
Настройки с помощью функции “Начальные установки”/“Простая установка”.....	12
Меню HOME/MEDIA	13
Воспроизведение фотографий, музыки и видео.....	13
Использование содержимого сети.....	15
Использование сетевых служб	16
Воспроизведение видео с YouTube™	16
Расширенные операции воспроизведения	17
Экранное меню	17
Меню состояния	18
Использование функции “Закладка”	19
Программное воспроизведение.....	19
Использование поиска	19
Просмотр BONUSVIEW™ и BD-Live™	20
Использование функции “Картинка в картинке” (воспроизведение вторичного аудио/видеосигнала)	20
Использование возможностей BD-Live™.....	20

4. Установки

Меню УСТАНОВКИ	21
Пример выполнения операции с помощью меню УСТАНОВКИ	23
Общие установки	24
Настройка дисплея	26
Настройка звука	27
Информация о системе	27
Форматы аудиовыходов	28
Форматы видеовыходов	29
Обновление программного обеспечения ...	30
Обновление программного обеспечения	30

5. Дополнительная информация

Устранение неисправностей	31
Питание	31
Основные операции	31
Воспроизведение диска	31
Изображение	32
Звук.....	32
Сеть.....	33
Сообщения на экране.....	33
Глоссарий	34
Технические характеристики	35
Общая часть	35
Входные/выходные терминалы	35
Авторское право	36
Алфавитный указатель	37

(в конце руководства)

Information about software	i
---	----------

■ Об этом руководстве

- В данном руководстве описывается управление проигрывателем с помощью пульта дистанционного управления за исключением случаев, когда такой тип управления недоступен. Некоторые из описанных действий можно также выполнять с помощью кнопок на передней панели.
- Примечания содержат важную информацию о безопасности и инструкции по эксплуатации. Советы содержат полезную информацию для работы с устройством.
- Это руководство отпечатано до производства устройства. Конструкция и технические характеристики могут быть частично изменены в результате усовершенствований и т.д. В случае различий между руководством и устройством приоритет имеет устройство.

Значки, используемые в данном руководстве

Значки используются для обозначения доступных для определенного формата кнопок или функций. Для получения дополнительной информации о типах дисков и форматах, которые можно воспроизвести, см. стр. 3.

- BD** : BD-Видео
- DVD** : DVD-Видео, DVD-VR, DVD+VR
- CD** : Аудио CD
- VIDEO** : Видеофайлы
- MUSIC** : Аудиофайлы
- PHOTO** : Файлы фотографий

Возможности этого проигрывателя

Простая настройка языка, разрешения, соотношения сторон экрана → стр. 12

Можно выполнить настройки языка и телевизора.

Воспроизведение доступных в продаже дисков Blu-ray Disc™/Blu-ray 3D™/DVD/CD* → стр. 17

Кроме дисков Blu-ray, на этом проигрывателе можно воспроизводить множество других дисков.

Воспроизведение BONUSVIEW™, BD-Live™ и т.д.* → стр. 20

Можно посмотреть дополнительные фильмы, содержащиеся на последних дисках Blu-ray.

Воспроизведение видеофайлов, музыкальных файлов или файлов фотографий, содержащихся на диске или устройстве памяти USB* → стр. 13

На этом проигрывателе можно воспроизвести файлы, записанные на диски или устройства памяти USB.

Воспроизведение видеофайлов, музыкальных файлов или файлов фотографий, содержащихся на сервере домашней сети* ** → стр. 15

Можно воспроизвести содержимое ПК с помощью телевизора или аудио/видео ресивера, подсоединив этот проигрыватель к серверу сети.

Управление телевизором, аудио/видео ресивером и т.д. с помощью прилагаемого пульта дистанционного управления → стр. 24

Соединив устройства кабелем HDMI, можно управлять ими с одного пульта дистанционного управления с помощью функции “HDMI контроль”.

Распределение содержимого воспроизведения по сетевым службам** → стр. 16

С помощью этого проигрывателя можно мгновенно воспроизводить видео через Интернет.

* Для получения дополнительной информации о типах дисков и форматах, которые можно воспроизвести, см. стр. 3.

** Для использования этой функции необходимо выполнить настройки сети.

Прилагаемые компоненты

Убедитесь, что к изделию прилагаются следующие аксессуары.

Пульт дистанционного



Батарейки (x2)
(AAA, R03, UM-4)

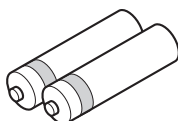

■ Типы дисков/файлов, которые можно использовать с этим проигрывателем

- На этом проигрывателе можно воспроизводить диски диаметром 12 см и 8 см. Не используйте адаптер 12 см для дисков 8 см.
- Используйте диски, соответствующие совместимым стандартам, что обозначается наличием официальных логотипов на этикетке диска. Воспроизведение дисков, не соответствующих данным стандартам, не гарантируется. Кроме того, не гарантируется качество изображения или качество звука даже в том случае, если данные диски могут быть воспроизведены.

Тип носителя	Формат записи
BD-ROM/BD-R/ BD-RE	BD-Video/файлы с данными
DVD-ROM	DVD-Video
DVD-R/DVD-R DL/DVD-RW	DVD-Video/DVD-VR/AVCHD/файлы с данными
DVD+R/DVD+R DL/DVD+RW	DVD-Video/DVD+VR/AVCHD/файлы с данными
CD-ROM	CDDA/HDCD
CD-R/CD-RW	CDDA/файлы с данными
USB*	Файлы с данными
DLNA	Файлы с данными

* Этот проигрыватель совместим с устройствами памяти USB, отформатированными в файловой системе FAT 16/32 и NTFS.

Поддерживаемые форматы аудиофайлов	Поддерживаемые форматы видеофайлов	Поддерживаемые форматы файлов фотографий
MUSIC	VIDEO	PHOTO
MP3 (.mp3) WMA (.wma) AAC (.aac/m4a) WAV (.wav) FLAC (.flac)	MKV с H.264 (.mkv) MPEG PS (.mpeg/ .mpg) MPEG TS (.ts) MPEG-4 (.mp4) VOB (.vob) AVI (.avi) ASF (.asf) WMV (.wmv)	JPEG (.jpeg/.jpg) GIF (.gif) PNG (.png)



Примечания

- Воспроизведение файлов, перечисленных в списке, не гарантируется в зависимости от способов создания файла или использованных кодеков.
- Файлы, защищенные авторским правом, не удастся воспроизвести.
- При использовании носителя DLNA файл должен соответствовать требованию сервера DLNA.

Информация о выборе региона для видеформата Blu-ray Disc/DVD

- Видеопроеигрыватели и диски Blu-ray Disc/DVD имеют региональные коды, указывающие регионы, в которых диск может быть воспроизведен. Проверьте метку с кодом региона на задней панели проигрывателя.
- Для воспроизведения диска Blu-ray Disc требуется проигрыватель с таким же кодом региона, для которого предназначен диск, или с кодом региона “ABC”.

- Для воспроизведения диска DVD требуется проигрыватель с таким же кодом региона, для которого предназначен диск, или с кодом региона “ALL”.

Примеры кодов региона	
BD-Video	DVD-Video
Код региона “A” или “ABC”	Код региона “1” или “ALL”
	

Примечания

- Операции с видеодисками Blu-ray Disc/DVD могут отличаться от пояснений в данном руководстве, а некоторые операции могут быть запрещены по установке изготовителя диска.
- Если во время воспроизведения диска появляется экран меню или инструкции по работе, следуйте указанному процессу.
- Воспроизведение некоторых дисков может быть невозможным в зависимости от диска.
- Все носители записи, воспроизводимые на этом проигрывателе, должны быть финализированы.
- “Финализация” означает обработку записываемого диска записывающим устройством, с тем, чтобы его можно было воспроизводить в других проигрывателях/записывающих устройствах, в том числе и с помощью данного проигрывателя. На данном проигрывателе можно воспроизвести только финализированные диски. (Этот проигрыватель не оснащен функцией финализации дисков.)
- Воспроизведение всех файлов на диске, устройстве памяти USB или в сети не гарантируется.
- Файл, защищенный авторским правом, не удастся воспроизвести с помощью устройства памяти USB или сети.

Требование к аудиофайлу

- Частота дискретизации: в пределах 32–48 кГц (MP3/WMA), LPCM 44,1 кГц/16 бит/стерео (WAV), 192 кГц/24 бит (FLAC)
- Битрейт: в пределах 8–320 кбит/с (MP3), 32–192 кбит/с (WMA)

Требования к файлу WMV

- WMV9 с максимальным разрешением 1920 × 1080.

■ Загрузка диска

- Диск должен быть расположен таким образом, чтобы этикетка была наверху.
- В случае, если диск записан с обеих сторон, разместите его так, чтобы сторона для воспроизведения была внизу.

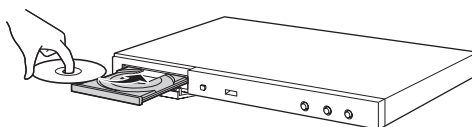

Продолжение на следующей ➔

Примечания

- В зависимости от диска и настроек проигрывателя воспроизведение может начаться автоматически.
- В зависимости от диска сначала может появиться меню.
- Время загрузки диска может варьировать в зависимости от диска.

■ Меры предосторожности при обращении с диском

Не допускайте появления царапин и попадания пыли

- Диски Blu-ray Disc, DVD и CD чувствительны к пыли, отпечаткам пальцев и особенно к царапинам. Поцарапанные диски не могут воспроизводиться. Обращайтесь с дисками осторожно и храните их в безопасном месте.

Правильное хранение дисков

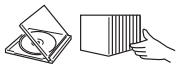
Поместите диск в центр футляра для диска и храните их в вертикальном положении.	
Не хранить диски в местах, подверженных попаданию прямых солнечных лучей, рядом с нагревательными приборами или в местах с высокой влажностью.	
Не роняйте диски и не подвергайте их сильной вибрации или ударам.	
Не храните диски в местах с высоким содержанием пыли или повышенной влажностью.	

Меры предосторожности при очистке



- Если поверхность загрязнена, осторожно вытрите ее мягкой, увлажненной (только водой) тканью. Протирая диски, всегда проводите тканью от центрального отверстия по направлению к внешнему краю.
- Не используйте аэрозоли для стирания надписей, бензин, обрабатывающие средства, жидкость для снятия статического электричества или любые другие растворители.
- Старайтесь не прикасаться к поверхности.
- Не приклеивайте на диск бумагу или наклейки.
- Если рабочая поверхность диска загрязнена или поцарапана, проигрыватель может воспринять его, как несовместимый, и открыть лоток диска, или может воспроизвести диск, но неправильно. Сотрите мягкой тканью грязь с рабочей поверхности.



Очистка считывающей линзы

- Ни в коем случае не используйте имеющиеся в продаже очищающие диски. Использование этих дисков может привести к повреждению линзы.
- Для очистки линзы обратитесь в ближайший сервисный центр, официально рекомендованный компанией Yamaha.

■ Примечание по просмотру видеоизображений в формате 3D

- Некоторые люди могут испытывать дискомфорт (например, напряжение глаз, утомление или тошнота) при просмотре видеоизображений в формате 3D. Мы рекомендуем всем зрителям делать регулярные перерывы при просмотре видеоизображений в формате 3D.
- Если вы испытываете какой-либо дискомфорт, прекратите просмотр видеоизображений в формате 3D, пока дискомфорт не пройдет. При наличии значительных неприятных ощущений обратитесь к врачу.
- Внимательно прочтите инструкции для владельца (на диске Blu-ray Disc и на экране телевизора) и/или предупреждающие сообщения на экране телевизора.
- Зрение маленьких детей (особенно детей младше шести лет) находится в стадии развития. Проконсультируйтесь с врачом (с педиатром или окулистом), прежде чем разрешать маленьким детям просмотр видеоизображений в формате 3D.
- Взрослые должны следить за маленькими детьми, чтобы гарантировать соблюдение представленных выше рекомендаций.

■ Технология Cinavia

- Технология Cinavia является частью системы защиты содержимого, встроенной в проигрыватель Blu-ray Disc.

Примечание

- Проигрыватель дисков Blu-ray Disc может отобразить следующие сообщения или приостановить вывод изображения или звука при попытке воспроизведения несанкционированной копии содержимого с технологией защиты Cinavia.

Сообщения отображаются только на английском языке.

Остановка воспроизведения. Воспроизводимое содержание охраняется технологией Cinavia™ и не разрешено для воспроизведения на этом устройстве. За дополнительной информацией обращайтесь на веб-сайт <http://www.cinavia.com>. Код сообщения 1.

Аудиовыход временно приглушен. Не настраивайте громкость воспроизведения. Воспроизводимое содержание охраняется технологией Cinavia™ и не разрешено для воспроизведения на этом устройстве. За дополнительной информацией обращайтесь на веб-сайт <http://www.cinavia.com>. Код сообщения 3.

Примечание относительно технологии Cinavia

В этом устройстве используется технология Cinavia, ограничивающая использование несанкционированных копий доступных в продаже фильмов, видеоматериалов и их звуковых дорожек. При обнаружении запрещенного использования несанкционированной копии на экране отобразится сообщение, и воспроизведение или копирование будет прервано. Для получения дополнительной информации о технологии Cinavia посетите веб-сайт Интерактивного информационного центра поддержки потребителей Cinavia по адресу <http://www.cinavia.com>. Чтобы запросить дополнительную информацию о технологии Cinavia по почте, отправьте почтовую карточку, указав на ней свой почтовый адрес, по адресу: Cinavia Consumer Information Center, P.O. Box 86851, San Diego, CA, 92138, США.

■ Передняя панель

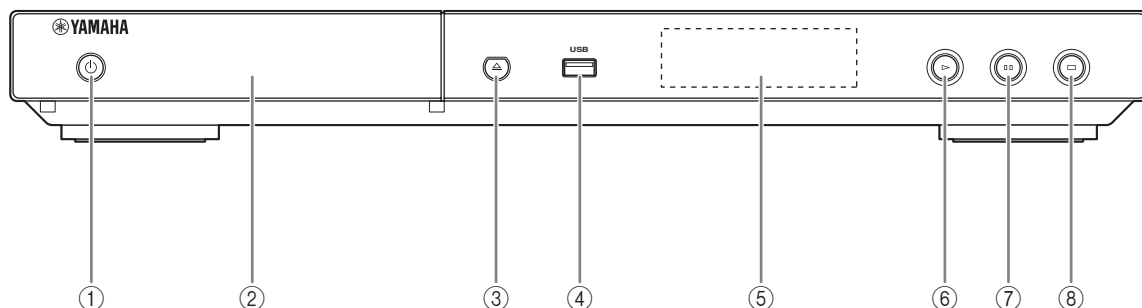

- ① **⏻ (Включение/Режим ожидания)**
Включение проигрывателя/переход в режим ожидания. Нажмите и удерживайте кнопку ⏻ на передней панели более 5 секунд, а затем отпустите, чтобы сбросить настройки проигрывателя (системный сброс).
- ② **Дверца лотка для дисков**
- ③ **▲ (Извлечение)**
Открытие и закрытие лотка диска.
- ④ **Разъем USB (стр. 11)**
- ⑤ **Дисплей передней панели**
Отображение различной информации о состоянии выполняемых действий.
- ⑥ **▶ (Воспроизведение)**
Начало воспроизведения.
- ⑦ **■ ■ (Пауза)**
Приостановка воспроизведения.
- ⑧ **■ (Остановка)**
Остановка воспроизведения.

Примечание

- При поставке с завода передняя панель проигрывателя закрыта защитной пленкой. Перед началом работы с проигрывателем снимите защитную пленку.

■ Задняя панель

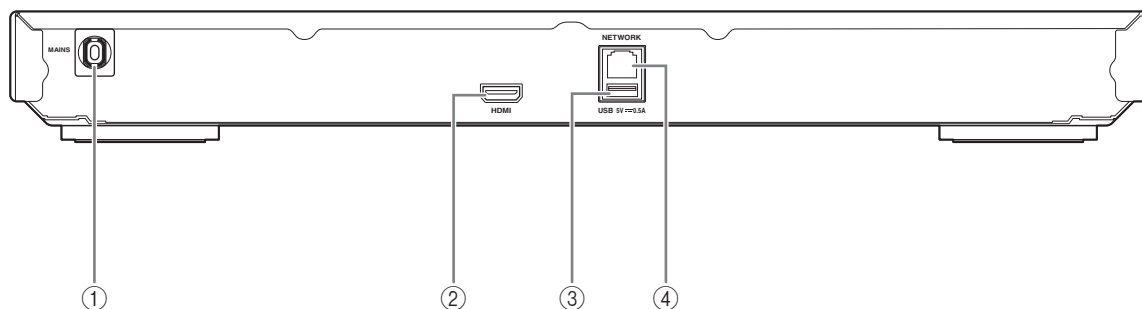

- ① **Кабель питания**
Проигрыватель оснащен встроенным кабелем питания. Прежде чем подключить его к розетке переменного тока, выполните предварительно все прочие подключения (стр. 10).
- ② **Разъем HDMI (стр. 10)**
- ③ **Разъем USB (стр. 11)**
- ④ **Разъем NETWORK (стр. 11)**

Примечание





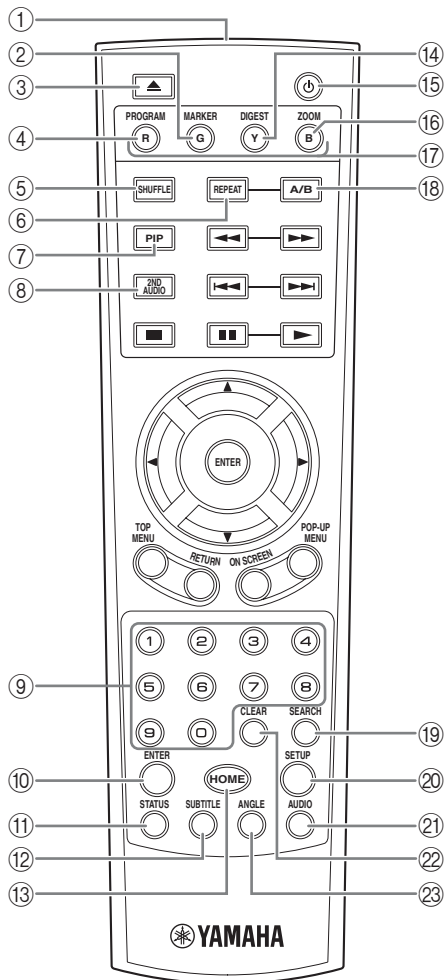

- Для предотвращения поражения электрическим током не прикасайтесь к неизолированным частям любых кабелей в то время, как кабель питания переменного тока подсоединен к розетке.

Пульт дистанционного управления

Примечание

-  отобразится в верхнем левом углу экрана при нажатии кнопки, которая недоступна.



- 1 Передатчик инфракрасных сигналов:** Используется для вывода инфракрасного сигнала. Наведите его на датчик дистанционного управления (стр. 9).
- 2 MARKER DVD VIDEO:** создается элемент “Закладка” (стр. 19) в выбранном месте фильма. После создания элемента “Закладка” нажмите кнопку **DIGEST**, чтобы выбрать установленную точку, к которой нужно перейти. Можно сохранить до 12 закладок.
- 3 ▲:** Открытие и закрытие лотка диска.
- 4 PROGRAM DVD CD:** Установка порядка воспроизведения (стр. 19). Можно установить до 15 дорожек (для аудиодиска) или заголовков/глав (DVD-Видео).
- 5 SHUFFLE DVD CD VIDEO MUSIC PHOTO:** Выбор режима воспроизведения в случайном порядке (стр. 17).
- 6 REPEAT BD DVD CD VIDEO MUSIC PHOTO:** Изменение режима повтора. Режимы повтора будут меняться при каждом нажатии кнопки, как показано далее.
 - : Повтор заголовка, воспроизводимого в данный момент.
 - : Повтор главы, воспроизводимой в данный момент.
 - : Повтор папки, воспроизводимой в данный момент.
 - : Повтор всех треков/файлов на диске.
 - : Повтор трека/файла, воспроизводимого в данный момент.
- 7 PIP BD:** Включение/выключение функции “Картинка в картинке” (стр. 20). Если эта функция доступна, на экране отображается PIP метка () . Этот элемент можно также выбрать в экранном меню (стр. 17).

Примечание

- PIP метка отображается, только если включен параметр “PIP метка” (стр. 25).

- 8 2ND AUDIO BD:** Выбор вторичного аудио функции “Картинка в картинке” (стр. 20) или аудиокментариев. На экране отображается Метка вторичного аудио () , если эта функция доступна (стр. 27). Этот элемент можно также выбрать в экранном меню (стр. 17).

Примечание

- Метка вторичного аудио отображается, только если включен параметр “Метка вторичного аудио” (стр. 25).

- ⑨ **Цифровые кнопки:** Ввод цифр, а также во время воспроизведения переход к треку/главе, которая соответствует введенному числу. Работа этих кнопок зависит от типа диска и состояния воспроизведения.
- ⑩ **ENTER:** Подтверждение выбранного меню/элемента.
- ⑪ **STATUS:** Отображение информации о воспроизведении (стр. 18).
- ⑫ **SUBTITLE [BD] [DVD] [VIDEO]:** Изменение языка субтитров (стр. 35) (при наличии). Этот элемент можно также выбрать в экранном меню (стр. 17).
- ⑬ **HOME:** Отображение на экране меню HOME (стр. 13).
- ⑭ **DIGEST [PHOTO]:** Отображение 12 пиктограмм фотографий. При отображении пиктограмм не удастся перейти к следующей/предыдущей странице с помощью кнопок ◀◀/▶▶.
- [DVD] [VIDEO]:** Отображение панели выбора элементов “Закладка” (стр. 19).
- ⑮ **⏸:** Включение проигрывателя или перевод в режим ожидания.
- ⑯ **ZOOM [DVD] [VIDEO] [PHOTO]:** Увеличение или уменьшение. Размер экрана будет изменяться при каждом нажатии кнопки (увеличение/уменьшение: по 3 уровня для каждого).
- ⑰ **Цветные кнопки [BD]:** Используйте эти кнопки в соответствии с инструкциями на экране.
- ⑱ **A/B [BD] [DVD] [CD] [VIDEO] [MUSIC]:** Воспроизведение определенного участка, который требуется повторить.
- 1 Нажмите **A/B** при просмотре момента, в котором требуется установить точку начала. На экране отобразится значок “A-”.
 - 2 Нажмите **A/B** еще раз при просмотре момента, в котором требуется установить точку окончания. На экране отобразится значок “A-B”. Начнется повторное воспроизведение.
 - 3 Чтобы отменить повторное воспроизведение, нажмите **A/B**. Значок “A-B” исчезнет, и повторное воспроизведение будет завершено.

Примечание

- Эту функцию, возможно, не удастся выполнить в зависимости от параметров диска.

- ⑲ **SEARCH [BD] [DVD] [CD] [VIDEO] [MUSIC]:** Быстрый переход к указанной точке во время воспроизведения. Для получения дополнительной информации об этой функции см. раздел “Использование поиска” (стр. 19). Этот элемент можно также выбрать в меню состояния (стр. 18).
- ⑳ **SETUP:** Отображение на экране меню УСТАНОВКИ (стр. 21).
- ㉑ **AUDIO [BD] [DVD]:** Изменение языка звучания или формата аудио. Этот элемент можно также выбрать в экранном меню (стр. 17).
- ㉒ **CLEAR:** Удаление введенного номера или установленного элемента.
- ㉓ **ANGLE [BD] [DVD]:** Изменение угла камеры, если видео записано с разными углами зрения. Если эта функция доступна, на экране отображается Угловая метка (📐). Этот элемент можно также выбрать в экранном меню (стр. 17).

Примечание

- Угловая метка отображается, только если включен параметр “Угловая метка” (стр. 25).

Продолжение на следующей ➔

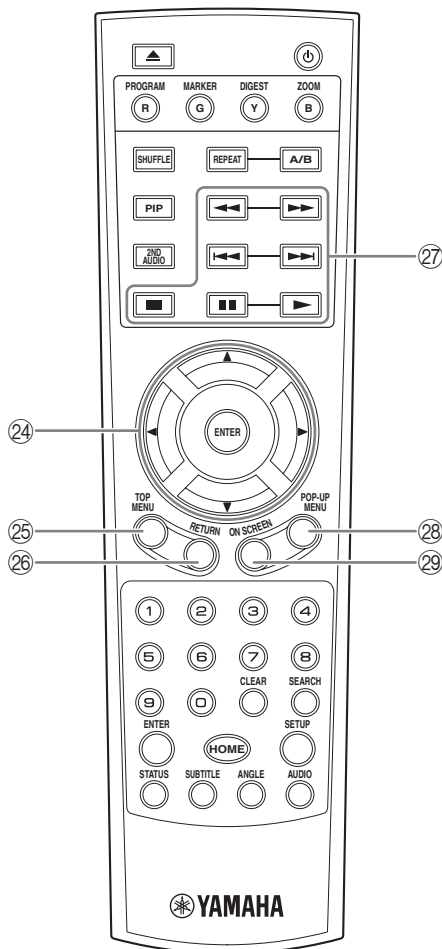

24 **Кнопки управления курсором (▲/▼/◀/▶):** Используются для перемещения по экрану меню. **ENTER:** подтверждение выбранного меню/элемента.

25 **TOP MENU [BD] [DVD]:** Отображение на экране главного меню, если оно имеется на диске. Выберите требуемый элемент с помощью кнопок ▲/▼/◀/▶ и нажмите **ENTER**.

Примечание

– В зависимости от диска некоторые операции могут отличаться. Следуйте указаниям на экранах меню.

26 **RETURN:** Возврат к предыдущему меню или экрану и т.д.

27 **Кнопки управления**

[BD] [DVD] [CD] [VIDEO] [MUSIC] [PHOTO]

■: Остановить воспроизведение. Для полной остановки воспроизведения нажмите эту кнопку дважды.

■ ■: Пауза в воспроизведении.

▶: Воспроизведение содержимого.



[BD] [DVD] [CD] [VIDEO] [MUSIC]:

Поиск вперед/назад. Скорость поиска будет меняться при каждом нажатии кнопки (поиск назад/поиск вперед: по 5 уровней для каждого). Нажмите ▶ для возобновления обычного воспроизведения.

[PHOTO]: Изменение скорости слайд-шоу (медленнее/быстрее: 3 уровня).

◀◀/▶▶: пропуск назад/вперед.

Примечание

– Проигрыватель возобновит воспроизведение с того места, где произошла остановка, в зависимости от диска. Для воспроизведения с начала дважды нажмите ■, а затем ▶.

28 **POP-UP/MENU [BD] [DVD]:** Отображение всплывающего меню. Содержание появившегося меню изменяется в зависимости от диска. Для получения дополнительной информации об управлении всплывающим меню обратитесь к руководству пользователя диска. В зависимости от диска DVD, главное меню можно вывести на экран, нажав кнопку **POP-UP/MENU**.

29 **ON SCREEN:** Отображение экранного меню (стр. 17).

Установка батарей в пульт дистанционного управления

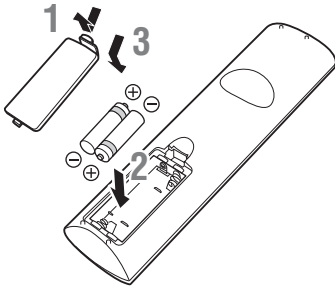

Примечания

- В случае уменьшения рабочего диапазона пульта дистанционного управления замените обе батарейки.
- Используйте батарейки типа AAA, R03, UM-4.
- При установке батареек соблюдайте полярность. См. изображение внутри отсека для батареек.
- Извлеките батарейки, если пульт дистанционного управления не будет использоваться в течение длительного периода времени.
- Не используйте старые батарейки вместе с новыми.
- Не используйте вместе батарейки разного типа (например, щелочные и марганцевые). Внимательно прочитайте информацию на упаковке, так как батарейки разного типа могут иметь одинаковую форму и цвет.
- Если батарейка начала протекать, незамедлительно утилизируйте ее. Не прикасайтесь к вытекшему электролиту и не допускайте его попадания на одежду и т.п. Перед установкой новых батареек тщательно очистите отсек для батареек.
- Не выбрасывайте батарейки вместе с бытовыми отходами. Утилизируйте их в соответствии с местным законодательством.
- Не давайте батарейки детям. Если ребенок случайно проглотил батарейку, незамедлительно обратитесь к врачу.
- Если пульт дистанционного управления не будет использоваться в течение длительного времени, извлеките из него батарейки.
- Не заряжайте и не разбирайте прилагаемые батарейки.

Приблизительный диапазон работы пульта дистанционного управления

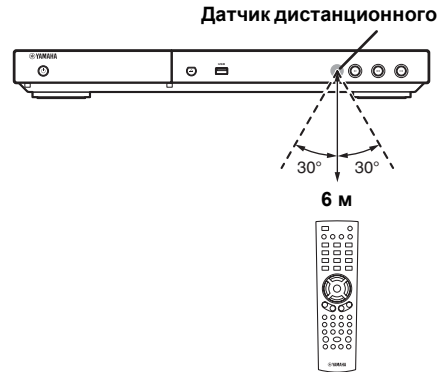

Подключение HDMI

■ Подключение к разъему HDMI

- Можно воспроизводить высококачественное цифровое изображение и звук с помощью разъема HDMI.
- Надежно подключите кабель HDMI (продается отдельно) к разъему HDMI.
- См. стр. 28 для получения информации о форматах аудио/видео для вывода.
- Используйте кабели HIGH SPEED HDMI, имеющие логотип HDMI (как указано на последней странице обложки).

Предупреждение!

Не подключайте кабель питания проигрывателя, пока не завершены все подключения.

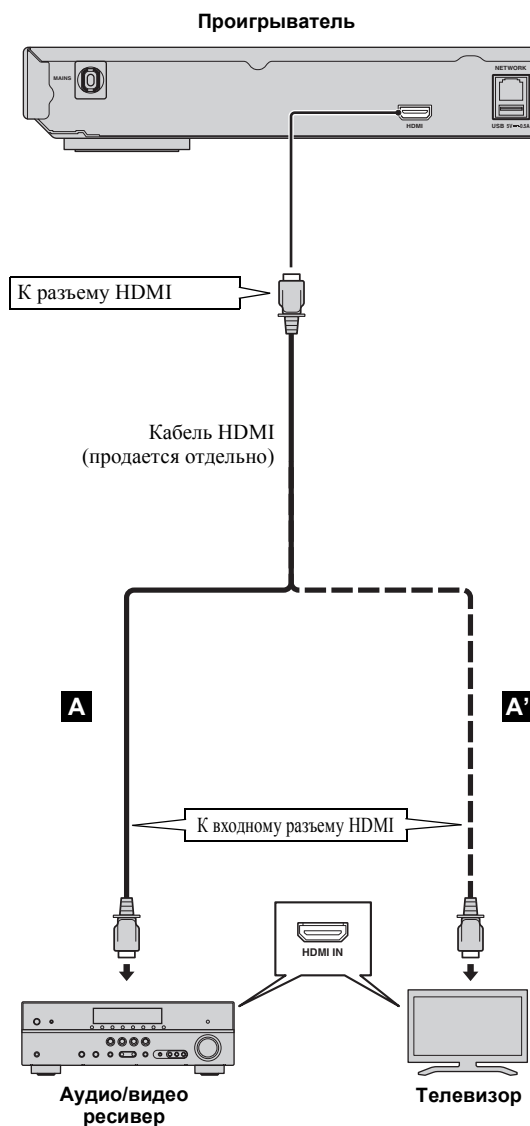

Советы

- При использовании функции "HDMI контроль" см. раздел "HDMI контроль" (стр. 24).
- Для получения информации о режиме вывода разъема HDMI см. раздел "HDMI" (стр. 27).
- Если изображение не появилось, см. раздел "Устранение неисправностей" (стр. 32).

■ Подключение для воспроизведения дисков Blu-ray 3D

Для воспроизведения дисков Blu-ray 3D с помощью этого проигрывателя требуется следующее оборудование и подключения.

- Телевизор и аудио/видео ресивер (если требуется) с функцией 3D.
- Все компоненты должны быть подключены с помощью кабелей HDMI.
- Диск Blu-ray Disc должен содержать изображения в формате 3D.
- Необходимо установить для параметра "3D Выход" в меню "Настройка дисплея" (стр. 26) значение Авто.

■ Подключение к разъему NETWORK

- Можно воспроизвести содержимое ПК, подключив проигрыватель к сети.
- Можно воспроизвести разнообразное содержимое с интерактивными функциями, подключившись к сети Интернет во время воспроизведения BD-Live-совместимых дисков. Для получения дополнительной информации о функциях BD-Live см. стр. 20.

Примечания

- Надежно подключите сетевой кабель (продается отдельно) к разъему NETWORK.
- Используйте для этой цели только сетевой кабель типа STP (экранированная витая пара).
- При использовании Интернет требуется широкополосный доступ в Интернет, как показано ниже.
- Другой конец сетевого кабеля подключите к концентратору или широкополосному маршрутизатору.
- При использовании широкополосного доступа в Интернет необходим договор с провайдером услуг Интернет. Для получения более подробной информации обратитесь к ближайшему провайдеру услуг Интернет.
- Обратитесь к руководству пользователя данного оборудования, так как подключаемое оборудование и метод подключения могут различаться в зависимости от имеющейся инфраструктуры Интернет.
- Используйте сетевой кабель/маршрутизатор, поддерживающий 10BASE-T/100BASE-TX.

■ Подключение к разъему USB

- Можно подключить устройство памяти USB в качестве устройства “Запоминающее устройство” к разъему USB на задней панели (или на передней панели) проигрывателя, чтобы сохранить данные BD-Live или обновить программное обеспечение проигрывателя.
- Надежно подключите устройство памяти USB (продается отдельно) к разъему USB.

ПРЕДУПРЕЖДЕНИЕ!

- Не извлекайте устройство памяти USB и не вынимайте кабель питания из розетки во время выполнения операций для BD-Live (стр. 20) или обновления программного обеспечения.
- Не используйте удлинительный кабель USB при подключении устройства памяти USB к разъему USB проигрывателя. Использование удлинительного кабеля USB может помешать правильной работе проигрывателя.

Примечание

- Компания Yamaha не может гарантировать, что устройства памяти USB всех марок будут работать с данным проигрывателем.

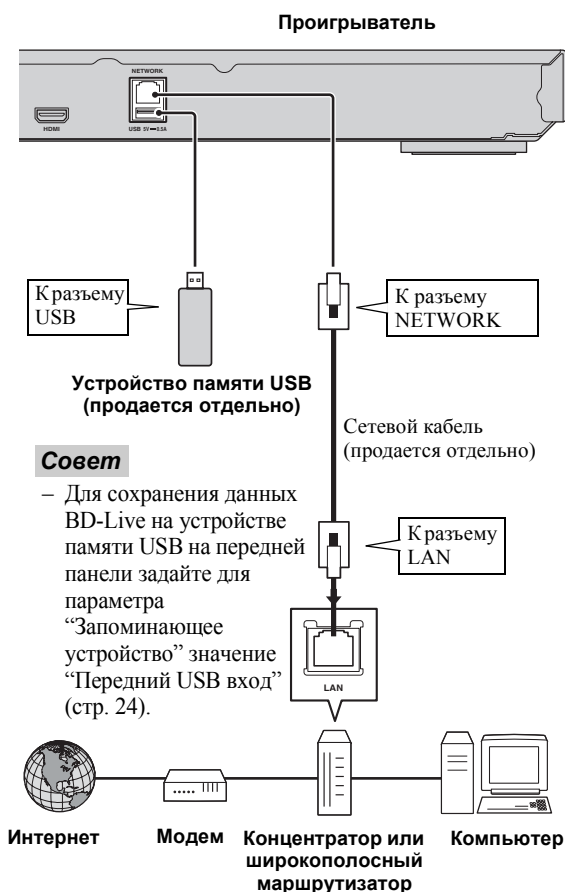

После подключения

- При выполнении настроек параметра “Сеть” вручную см. раздел “Сеть” (стр. 25).
- Чтобы воспроизвести содержимое ПК по сети, см. раздел “Использование содержимого сети” (стр. 15).

Начальные установки/Простая установка

■ Настройки с помощью функции “Начальные установки”/“Простая установка”

Функции “Начальные установки”/“Простая установка” позволяют легко установить язык, разрешение и соотношения сторон. Экран “Начальные установки” отображается при первом включении проигрывателя после покупки. Эти же настройки можно выполнить из меню УСТАНОВКИ → Система → Простая установка.

- 1 Когда отображается экран “Простая установка”, нажмите кнопку **ENTER**, чтобы запустить функцию “Простая установка”.

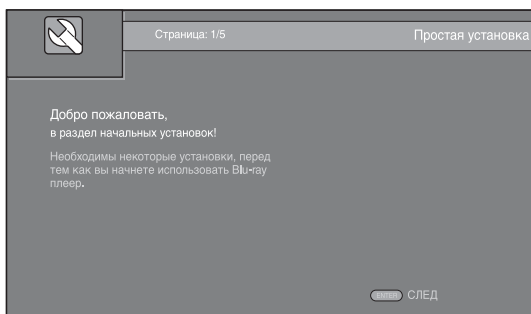

- 2 Настройте язык, разрешение и соотношение сторон экрана, следуя указаниям на экране.

Примечания

- Если после завершения работы функций “Начальные установки”/“Простая установка” изображения не появилось, см. раздел “Устранение неисправностей” (стр. 32).
- При включении проигрывателя появится предупреждающее сообщение, касающееся воспроизведения видео в формате 3D. Нажмите **ENTER**, чтобы закрыть сообщение или **CLEAR**, чтобы отключить его (стр. 24).

Меню HOME/MEDIA

В меню HOME и MEDIA можно просмотреть и воспроизвести все файлы мультимедиа на дисках с данными, устройствах памяти USB и в домашней сети.

Примечание

- Для получения дополнительной информации о типах дисков и форматах, которые можно воспроизвести, см. стр. 3.

■ Воспроизведение фотографий, музыки и видео

Основные операции

◀/▶/▲/▼: Перемещение по экрану.

◀: Возврат в корневую папку.

HOME: Переход на экран/выход с экрана меню HOME.

ENTER: Подтверждение папки или файла.

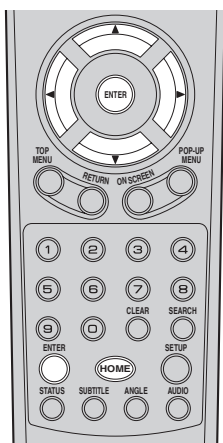

Значки на первой странице меню MEDIA

: Воспроизведение диска в лотке или отображение содержимого диска с данными.

: Отображение содержимого устройства памяти USB, подключенного к разъему USB.

: Поиск сервера DLNA (стр. 15) в сети.

: Отображение содержимого подключенного сервера DLNA.

Основные операции для воспроизведения файлов в выбранной папке

Пример: Выбор фильма на устройстве памяти USB

Примечание

- Перед тем, как перейти на экран меню MEDIA, остановите воспроизведение видео.

- 1 Нажмите кнопку **HOME** для отображения экрана меню HOME.

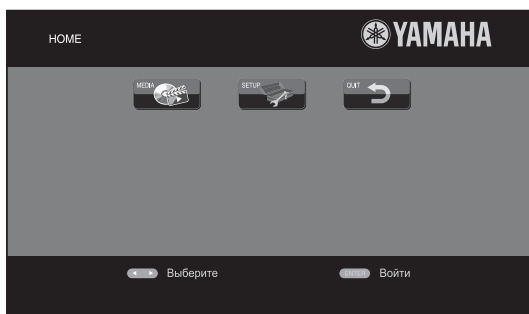

Совет

- Экран меню HOME может отличаться в зависимости от модели.

- 2 С помощью кнопок ◀/▶/▲/▼ выберите элемент “MEDIA”, а затем нажмите кнопку **ENTER**. Появится экран MEDIA.

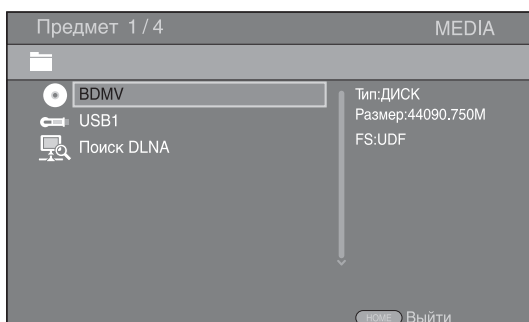

3

Воспроизведение

Русский

Продолжение на следующей ➔

- 3 Выберите элемент, содержащий файл, который требуется воспроизвести, и нажмите **ENTER**.

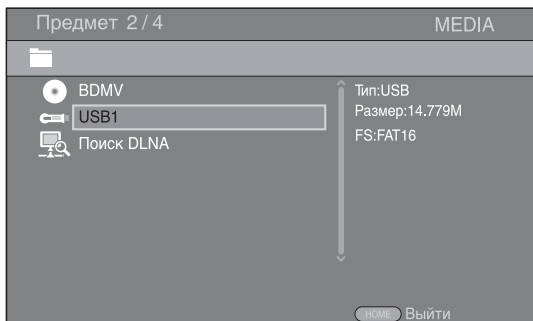

- 4 Выберите папку “Фото”, “Музыка”, “ВИДЕО” или “AVCHD”, которую требуется воспроизвести, и нажмите **ENTER**.

Чтобы вернуться в корневую папку, нажмите ◀ или выберите значок ▲.

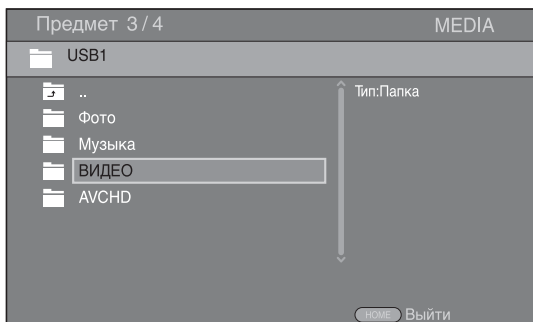

Примечание

- Обратите внимание, что в следующем шаге будет отображен только тип файлов, выбранный в этом шаге. Например, если в этом шаге выбрать папку “Фото”, то в следующем шаге будут отображены только файлы фотографий. Чтобы воспроизвести другие файлы, кроме фотографий, вернитесь к этому шагу и снова выберите тип файлов.

- 5 Выберите папки, содержащие файлы, которые требуется воспроизвести.

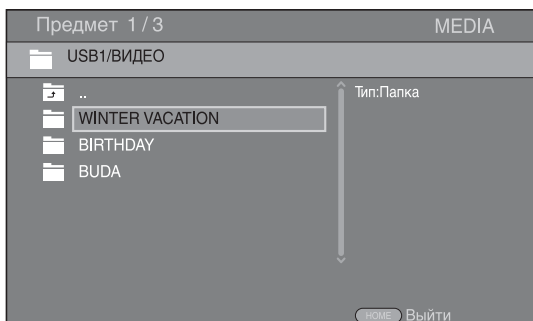

- 6 Выберите файл, который требуется воспроизвести, и нажмите **ENTER**.

При выборе видеофайла начнется воспроизведение.

При выборе музыкального файла отобразится экран состояния и начнется воспроизведение.

При выборе файла фотографии начнется слайд-шоу.

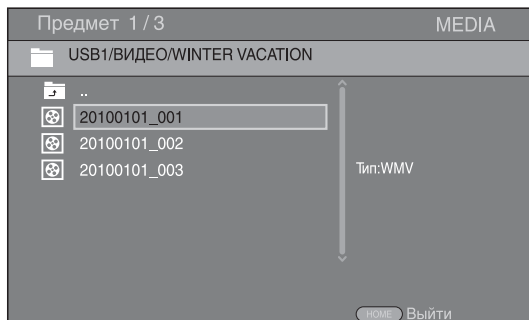

Совет

- Чтобы просматривать слайд-шоу с музыкой, нажмите **HOME** для возврата на экран меню HOME во время воспроизведения музыки и выберите файл фотографии.

Примечание

- Отображаемый файл, возможно, не удастся воспроизвести в зависимости от содержимого.

Операции для просмотра фотографий

Во время просмотра фотографий кнопки на пульте дистанционного управления работают следующим образом.

- : остановка слайд-шоу и возврат к диспетчеру файлов.
- : приостановка слайд-шоу.
- ▶: показ слайд-шоу.
- ▶▶: переход к следующей фотографии.
- ◀◀: переход к предыдущей фотографии.
- ▶▶▶: увеличение скорости слайд-шоу на 3 уровня.
- ◀◀◀: уменьшение скорости слайд-шоу на 3 уровня.
- ▲: инвертирование фотографии.
- ▼: зеркальное отражение фотографии.
- ◀: поворот фотографии против часовой стрелки.
- ▶: поворот фотографии по часовой стрелке.
- ZOOM**: увеличение/уменьшение фотографии (увеличение/уменьшение: по 3 уровня для каждого).
 - ▲/▼/◀/▶: режим увеличения с панорамированием, когда размер фотографии больше экрана.

DIGEST: переключение в режим пиктограмм (стр. 7). При отображении пиктограмм не удастся перейти к следующей/предыдущей странице с помощью кнопок ◀◀/▶▶.

■ Использование содержимого сети

Этот проигрыватель сертифицирован по стандарту DLNA (стр. 34). С его помощью можно управлять фотографиями, музыкой и видео, которые хранятся на серверах DLNA в домашней сети.

Воспроизведение общего содержимого

- 1 Чтобы воспроизводить файлы на компьютере, установите программное обеспечение DLNA, например Windows Media Player 12, и сделайте файлы, которые требуется воспроизвести, доступными для совместного использования.
- 2 Включите компьютер с установленным программным обеспечением для поддержки серверов DLNA или устройство DLNA, подключенное к домашней сети.
- 3 Нажмите **HOME** для отображения экрана меню HOME. Затем выберите MEDIA, чтобы перейти к меню MEDIA. На этом экране перечислены серверы DLNA, подключенные к сети.

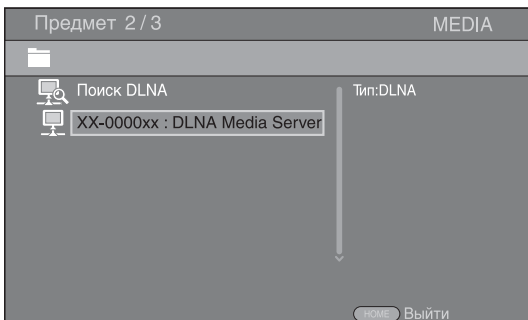

Примечания

- Если требуемый сервер DLNA отсутствует в списке, выберите пункт “Поиск DLNA”, чтобы найти его.
 - В зависимости от сервера DLNA, возможно, потребуется разрешить на сервере доступ проигрывателю.
 - Чтобы воспроизвести файл на сервере DLNA, проигрыватель и сервер должны быть подключены к одной точке доступа.
 - Некоторые файлы могут быть несовместимыми в силу своих требований. Доступ к файлу может быть ограничен в зависимости от характеристик файла и возможностей сервера DLNA.
- 4 Выберите файл, который требуется воспроизвести.

Примечания

- Качество воспроизведения и работы может зависеть от условий домашней сети.
- Возможно, не удастся правильно предоставить совместный доступ к файлам, сохраненным на съемных носителях, например устройствах памяти USB или DVD-приводе медиасервера.

Использование сетевых служб

Можно мгновенно просмотреть видеоизображения, предоставляемые следующими сетевыми службами.

- YouTube

Примечания

- Для доступа к содержимому, предоставляемому третьими сторонами, требуется высокоскоростное подключение к Интернету, а также может потребоваться регистрация учетной записи и платной подписки.
- Услуги третьих сторон по предоставлению содержимого могут быть изменены, приостановлены, прерваны или прекращены в любое время без уведомления, при этом компания Yamaha снимает с себя какую-либо ответственность, связанную с подобными случаями.
- Некоторые виды содержимого могут быть доступны только для конкретных стран и могут быть представлены на определенных языках.
- Компания Yamaha не предоставляет и не гарантирует продолжение оказания или доступности услуг по предоставлению содержимого в течение конкретного периода времени, и любые подобные гарантии, явные или подразумеваемые, не признаются.

Воспроизведение видео с YouTube™

С помощью этого проигрывателя можно просматривать фильмы с YouTube через Интернет.

Данные услуги могут быть изменены без уведомления.

- 1 Нажмите **HOME** для отображения экрана меню HOME.

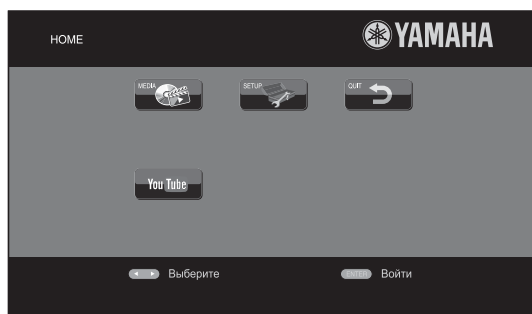

Совет

- Экран меню HOME может отличаться в зависимости от модели.

- 2 С помощью кнопок ◀/▶/▲/▼ выберите элемент “YouTube”, а затем нажмите кнопку **ENTER**.

Совет

- Для возврата на экран меню HOME нажмите **RETURN**.

Расширенные операции воспроизведения

В этой главе описывается процесс воспроизведения имеющихся в продаже дисков Blu-ray, DVD и CD, а также записанных дисков DVD-RW/R.

Примечание

- Описание основных операций воспроизведения см. на стр. 6

■ Экранное меню

Чтобы отобразить экранное меню, нажмите **ON SCREEN**. Затем нажмите **▲/▼/◀/▶**, чтобы выбрать пункт, и нажмите **ENTER**, чтобы выполнить требуемую функцию.

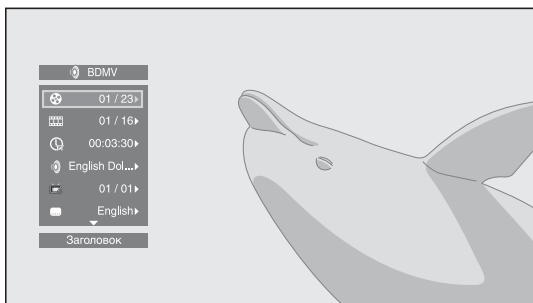

В экранном меню содержатся следующие пункты.

Заголовок **BD** **DVD** **VIDEO**: отображение номера заголовка, воспроизводимого в данный момент. Можно пропустить требуемый заголовок, выбрав его в этом пункте.

Глава **BD** **DVD** **VIDEO**: отображение номера главы, воспроизводимой в данный момент. Можно пропустить требуемую главу, выбрав ее в этом пункте.

Трек/Файл **CD** **VIDEO** **MUSIC** **PHOTO**: отображение номера трека/файла, воспроизводимого в данный момент. Можно пропустить требуемый трек/файл, выбрав его в этом пункте.

Время **BD** **DVD** **CD** **VIDEO** **MUSIC**: отображение времени воспроизведения. Выберите подходящий тип отображения:

- Прошедшее время воспроизведения заголовка, главы, трека или файла
- Оставшееся время воспроизведения заголовка, главы, трека или файла

Режим/Режим воспроизведения

DVD **CD** **VIDEO** **MUSIC** **PHOTO**: отображение текущего режима воспроизведения. Можно выбрать один из следующих режимов воспроизведения:

- CD**
 - Нормальный: обычное воспроизведение.
 - Перемешать: воспроизведение в случайном порядке без повтора.
 - Случайный: воспроизведение в случайном порядке с повтором.

DVD

- Нормальный
- Перемешать главы (глава)
- Перемешать заголовки (заголовок)
- Перемешать все
- Случайные CH (глава)
- Случайные TT (заголовок)
- Случайные Все

VIDEO MUSIC PHOTO

- Нормальный
- Перемешать F (папка)
- Случайный F (папка)

Аудио **BD** **DVD** **VIDEO**: отображение текущего режима воспроизведения Blu-ray Disc/DVD. Возможен выбор нужного типа аудио.

Угол **BD** **DVD**: отображение выбранного в данный момент номера угла зрения. При наличии записи с несколькими углами зрения можно изменить угол зрения.

Субтитры **BD** **DVD** **VIDEO**: отображение выбранного в данный момент языка субтитров, если они имеются.

Стиль субтитров **BD**: отображение выбранного в данный момент стиля субтитров. Эту функцию можно использовать только для внешних субтитров видеофайла. Можно выбрать требуемый стиль текста субтитров.

Битрейт **BD** **DVD** **CD** **VIDEO** **MUSIC**: отображение скорости передачи данных аудио/видеосигнала.

Вторичное видео **BD**: включение/отключение функции PIP (стр. 6).

Вторичное аудио **BD**: включение/отключение функции вторичного аудио (стр. 6).

Мгновенный Поиск

BD **DVD** **CD** **VIDEO** **MUSIC**: пропуск 30 секунд.

Мгновенный Повтор

BD **DVD** **CD** **VIDEO** **MUSIC**: повторное воспроизведение содержимого, начиная с точки за 10 секунд до данного момента.

Слайд-шоу

PHOTO:

отображение скорости слайд-шоу. Можно выбрать следующие значения скорости слайд-шоу: Медленно/Средний/Быстро.

Перемещение **PHOTO**: просмотр того, как фотография отображается на экране. Можно выбрать тип перемещения.

■ Меню состояния

Используется для отображения различных настроек: субтитры, установки угла зрения, а также номер заголовка/главы/трека, воспроизводимых в данный момент. Чтобы отобразить меню состояния, нажмите **STATUS**. В меню состояния содержатся следующие меню.

BD DVD VIDEO

Пример: значки при воспроизведении диска Blu-ray Disc

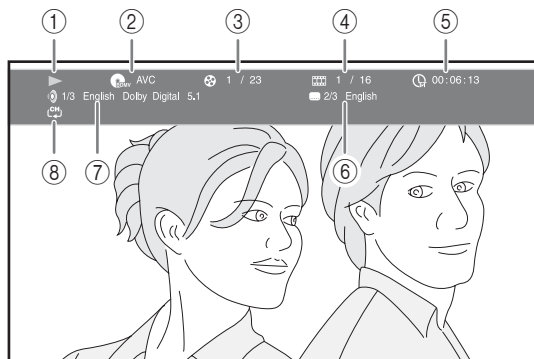

- ① **▶ (Воспроизведение)**
- ② **BD/MV (Значок типа диска/видеофайла)**
- ③ **⊗ (Номер воспроизводимого заголовка):** можно перейти к требуемому заголовку с помощью кнопки **SEARCH** (стр. 7).
- ④ **⌂ (Номер воспроизводимой главы):** можно перейти к требуемой главе с помощью кнопки **SEARCH** (стр. 7).
- ⑤ **⌚ (Прошедшее время воспроизведения):** можно перейти к определенной точке с помощью кнопки **SEARCH** (стр. 7).
- ⑥ **⋮ (Текущие субтитры):** можно выбрать язык субтитров с помощью кнопки **SUBTITLE**.
- ⑦ **🔊 (Текущий звук):** можно выбрать язык или формат звучания с помощью кнопки **AUDIO**.
- ⑧ **↺ (Режим повтора):** отображение текущего режима повтора (стр. 6).

CD MUSIC

Пример: значки при воспроизведении музыкального файла

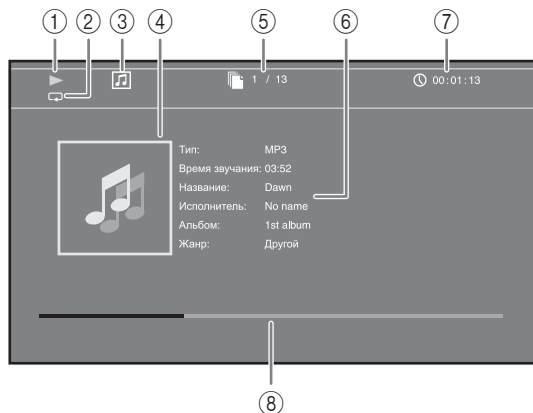

- ① **▶ (Воспроизведение)**
- ② **↺ (Режим повтора):** отображение текущего режима повтора (стр. 6).
- ③ **🎵 (Значок типа диска/музыкального файла)**
- ④ **(Изображение) MUSIC:** Отображение рисунка, если он содержится в файле.
- ⑤ **📄 (Номер воспроизводимого трека/файла):** можно перейти к требуемому треку с помощью кнопки **SEARCH** (стр. 7).
- ⑥ **(Информация) MUSIC:** Отображение информации о композиции, если она содержится в файле.
- ⑦ **⌚ (Прошедшее время воспроизведения):** можно перейти к определенной точке с помощью кнопки **SEARCH** (стр. 7).
- ⑧ **(Полоса воспроизведения) MUSIC:** Отображение состояния воспроизведения текущей композиции.

PHOTO



- ① **▶ (Воспроизведение)**
- ② **🖼️ (Значок файла фотографии)**
- ③ **📄 (Номер отображаемого файла)**
- ④ **↺ (Режим повтора):** отображение текущего режима повтора (стр. 6).
- ⑤ **(Скорость слайд-шоу)**

■ Использование функции “Закладка” **DVD VIDEO**

Используется для создания элемента “Закладка” в указанной точке видеофайла. После создания элемента “Закладка” с помощью данной функции можно перейти к этой точке. Можно сохранить до 12 закладок.

- 1 Нажмите кнопку **MARKER** во время воспроизведения фильма, чтоб создать элемент “Закладка”. Отобразятся номер элемента “Закладка” и состояние.

Закладка: 1/12 Заголовок: 1 Глава: 1 Время: 00:01:26

- 2 После создания элемента “Закладка” нажмите кнопку **DIGEST**, чтобы отобразить панель выбора элементов “Закладка”.

Заголовок:01 Глава:01 Время: 00:01:26 Закладка
 01 02 03 04 05 06 07 08 09 10 11 12

- 3 Нажмите **◀▶**, чтобы выбрать элемент “Закладка”, который требуется воспроизвести, и нажмите **ENTER**. Нажмите **CLEAR**, чтобы удалить выбранный элемент “Закладка”.

Примечание

- По окончании воспроизведения (например, при извлечении диска или двойном нажатии **■**) закладки автоматически удаляются.

■ Программное воспроизведение **DVD CD**

Используется для программирования порядка воспроизведения треков аудиодисков или глав DVD. Нажмите **PROGRAM** во время воспроизведения, чтобы отобразить окно ПРОГРАММА и запрограммировать порядок воспроизведения. Можно запрограммировать до 15 треков/глав.

Пример: Программирование порядка воспроизведения треков CD

- 1 Нажмите **PROGRAM** во время воспроизведения.

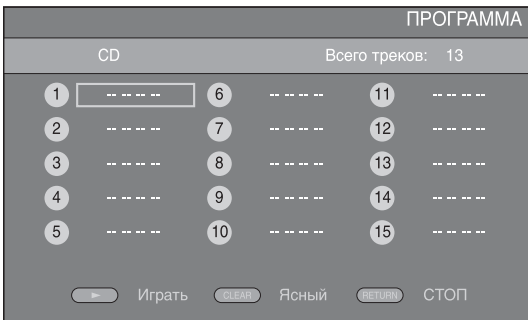

- 2 Нажмите **ENTER**, чтобы запрограммировать порядок воспроизведения. При воспроизведении аудиодисков выберите нужный трек с помощью кнопок **▲/▼**, а затем нажмите кнопку **ENTER**. При воспроизведении диска DVD-Видео выберите требуемый заголовок (отображаются с пометкой TT) и главу (отображаются с пометкой CH) вместо трека. Чтобы удалить выбранный трек из программы, выберите трек, который требуется удалить, и нажмите **CLEAR**. Чтобы отменить программное воспроизведение, нажмите **RETURN**.



- 3 Завершив программирование, нажмите **▶**, чтобы установить и запустить программное воспроизведение.
- 4 Чтобы отменить программное воспроизведение, полностью остановите воспроизведение, дважды нажав **■**.

■ Использование поиска

BD DVD CD VIDEO MUSIC PHOTO

Используется для быстрого перехода к указанной точке во время воспроизведения.

- 1 Нажмите **SEARCH** во время воспроизведения. Появится строка состояния.
- 2 Нажмите **▲/▼/◀▶**, чтобы выбрать один из перечисленных элементов, затем нажмите **ENTER**.

BD DVD :

- Номер заголовка (отображаются с пометкой **TT**)
- Номер главы (отображаются с пометкой **CH**)
- Прошедшее время заголовка (отображаются с пометкой **⌚**)
- Прошедшее время главы (отображаются с пометкой **⌚ CH**)

CD :

- Номер трека (отображаются с пометкой **⊙**)
- Прошедшее время трека (отображаются с пометкой **⌚ TRACK**)
- Прошедшее время диска (отображаются с пометкой **⌚ DISC**)

VIDEO MUSIC :

- Номер файла (отображаются с пометкой **📄**)
- Прошедшее время файла (отображаются с пометкой **⌚**)

PHOTO :

- Номер файла (отображаются с пометкой **📄**)

- 3 С помощью кнопок ▲/▼ или цифровых кнопок установите или отрегулируйте значение выбранного элемента и нажмите **ENTER**, чтобы перейти к указанной точке.
- 4 Чтобы закрыть строку состояния, нажмите **STATUS**.

■ Просмотр BONUSVIEW™ и BD-Live™

Этот проигрыватель поддерживает функции воспроизведения BONUSVIEW (стр. 34) (BD-ROM Профиль 1 Версия 1.1) и BD-Live (стр. 34) (BD-ROM Профиль 2).

Примечание

- Функции и способ воспроизведения могут отличаться в зависимости от диска. См. указания на диске или в прилагаемом руководстве пользователя.

■ Использование функции “Картинка в картинке” (воспроизведение вторичного аудио/видеосигнала)

BD-Видео, которое включает в себя функцию вторичного аудио/видео, совместимую с функцией Картинка в картинке, может одновременно воспроизводить вторичное аудио и видео в виде маленького видеокна в углу экрана.

Первичное видео Вторичное видео

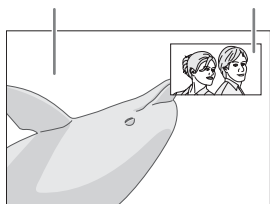

Если отображается PIP метка (PIP) или Метка вторичного аудио (A), нажмите кнопку PIP, чтобы включить или отключить функцию “Картинка в картинке”.

Примечания

- Для прослушивания вторичного аудио убедитесь, что для параметра “Аудиовыход” (HDMI) установлено значение “PCM” или “Перекодировать” (стр. 27).
- В зависимости от диска для прослушивания вторичного аудио, возможно, потребуется включить вторичное аудио в главном меню диска (стр. 8).
- Вторичное аудио и видео для функции Картинка в картинке может автоматически появляться и исчезать в зависимости от содержимого. Кроме того, области воспроизведения могут быть ограничены.

■ Использование возможностей BD-Live™

1. Выполните настройки сети (стр. 25).

2. Подключите устройство памяти USB к проигрывателю (стр. 11).

Данные BD-Live будут сохранены в устройстве памяти USB, подключенном к этому проигрывателю. Чтобы использовать эти функции, подключите устройство памяти USB, поддерживающее протокол USB 2.0 High Speed (480 Мбит/с), к разъему USB, выбранному в параметрах “Запоминающее устройство” (стр. 24). По умолчанию задан разъем USB на задней панели.

- При необходимости папка BUDA будет автоматически создана на устройстве памяти USB.
- Если на устройстве памяти будет недостаточно свободного места, данные не будут скопированы/загружены. Удалите ненужные данные или воспользуйтесь новым устройством памяти USB.
- Для загрузки данных (считывания/записи) может потребоваться некоторое время.

Примечания

- Компания Yamaha не может гарантировать, что устройства памяти USB всех марок будут работать с данным проигрывателем.
- Не используйте удлинительный кабель USB при подключении устройства памяти USB к разъему USB проигрывателя. Использование удлинительного кабеля USB может помешать правильной работе проигрывателя.

3. Воспроизведите диск.

4. Запустите BD-Live в соответствии с указаниями на диске.



Примечания

- Относительно способа воспроизведения содержимого BD-Live и т.п., выполняйте операции в соответствии с указаниями в руководстве диска Blu-ray Disc.
- Чтобы использовать функции BD-Live, установите сетевое подключение (стр. 11) и настройте параметр “Сеть” (стр. 25).
- Для получения информации об установке ограничения доступа к содержимому BD-Live см. раздел “BD-Live соединения” (стр. 25).
- Время, необходимое для загрузки предоставляемых программ на устройство памяти USB, подключаемое к данному проигрывателю, зависит от скорости Интернет-соединения и объема данных программ.
- С помощью программ BD-Live, предоставляемых через Интернет, возможно, не удастся отобразить соединение в зависимости от статуса (обновления) провайдера. В таких случаях извлеките диск и попробуйте еще раз.
- Причиной того, что при выборе функции BD-Live в меню диска Blu-ray Disc и по прохождении некоторого времени, не появляется экранное изображение BD-Live, может быть то, что на устройстве памяти USB недостаточно места. В таких случаях извлеките диск из проигрывателя, а затем удалите данные с устройства памяти USB, используя меню “Форматировать” в меню “Запоминающее устройство” (стр. 24).

Меню УСТАНОВКИ

Меню УСТАНОВКИ позволяет выполнять различные аудиовизуальные установки и настройки функций с помощью пульта дистанционного управления.

Меню/подменю	Элемент	Функция	Стр.	
 Общие установки	Система	Сохранение экрана	Включение и выключение хранителя экрана.	24
		Автоматическое воспроизведение дисков	Проигрыватель будет автоматически запускать воспроизведение дисков.	24
		HDMI контроль	Позволяет настроить проигрыватель для получения управляющего сигнала от пульта дистанционного управления телевизора или аудио/видео ресивера.	24
		Загрузка исходных параметров	Сброс всех настроек к значениям по умолчанию, кроме настроек параметра "Безопасность".	24
		Обновление программного обеспечения	Выполнение обновления проигрывателя.	24
		Простая установка	Настройка языка, разрешения, соотношения сторон экрана.	24
		Запоминающее устройство	Отображение состояния устройства "Запоминающее устройство" (стр. 24), форматирование устройства "Запоминающее устройство" и выбор переднего/заднего порта USB для устройства "Запоминающее устройство".	24
		Сообщение о 3D воспроизведении	Отображение предупреждающего сообщения, касающегося воспроизведения видео в формате 3D, при включении проигрывателя.	24
	Язык	Экранное меню	Выбор языка экранного меню.	24
		Меню диска	Установка приоритетного языка для меню диска.	24
		Аудио	Установка приоритетного языка для звучания.	24
		Субтитры	Установка приоритетного языка для субтитров.	25
	Воспроизведение	Угловая метка	Позволяет включать и выключать режим "Угловая метка" при воспроизведении диска Blu-ray Disc/DVD, записанного с разными углами зрения.	25
		PIP метка	Позволяет включать и выключать режим "PIP метка" при воспроизведении диска Blu-ray Disc/DVD с функцией "Картинка в картинке".	25
		Метка вторичного аудио	Позволяет включать и выключать режим "Метка вторичного аудио" при воспроизведении диска Blu-ray Disc/DVD, записанного с дополнительной звуковой дорожкой.	25
		Последняя память	Проигрыватель запоминает место на диске, где было остановлено воспроизведение последнего файла, при переходе в режим ожидания или в случае открытия лотка диска.	25
	Безопасность	Изменение пароля	Изменение пароля для функции "Родительский контроль" и "Код страны".	25
		Родительский контроль	Позволяет включать функцию "Родительский контроль" в зависимости от содержания диска.	25
		Код страны	Установка "Код страны".	25
	Сеть	Подключение к Интернет	Установка для параметра "Подключение к Интернет" значения "Разрешать"/"Выключать".	25
		Информация	Отображение экрана с информацией о сети.	25
		Проверка соединения	Выполнение проверки соединения с сетью.	25
		Настройка IP	Установка для параметра "Настройка IP" значения "Авто" или "Вручную".	25
		BD-Live соединения	Установка для подключения BD-Live значения "Разрешенное", "Частичное Разрешенное" или "Запрещенные".	25
		DLNA	Установка для параметра DLNA значения "Разрешать" или "Выключать".	25
		Настройки прокси-сервера	Выполнение настроек прокси-сервера.	26

Меню/подменю	Элемент	Функция	Стр.	
 Настройка дисплея	TV	3D Выход	Выбор видеоизображения в формате 3D или 2D.	26
		ТВ экран	Можно установить соотношение сторон экрана подключенного телевизора и отрегулировать выводимое изображение.	26
		Выбор видео выхода	Выбор разрешения выводимого изображения.	26
		ТВ система	Установка для параметра “ТВ система” значения “NTSC”, “PAL” или “Мультисистемный”.	26
		Цветовое пространство	Установка для параметра “Цветовое пространство” значения “YCbCr 4:4:4”, “YCbCr 4:2:2”, “Full RGB” или “RGB”.	26
		HDMI Deep Color	Установка для параметра “HDMI Deep Color” значения “30 bits”, “36 bits”, “48 bits” или “Выкл”.	26
		HDMI 1080p 24Hz	Установка для параметра “HDMI 1080p 24Hz” значения “Авто” или “Выкл”.	27
		Lip Sync	Настройка задержки между видео и аудио, например в случае, когда движение губ не синхронизировано с речью.	27
	Видео обработка	Режим видеосъемки	Настройка видимого изображения.	27
		Color Adjust	Настройка параметров “Яркость”, “Насыщенность” и “Оттенок” для каждого цвета.	27
		Шумоподавление	Установка уровня параметра “Шумоподавление”.	27
Режим деинтерлейсинга		Выбор способа обнаружения видеосигнала.	27	
 Настройка звука	Аудиовыход	HDMI	Установка для разъема HDMI режима вывода “Bitstream”, “PCM”, “Перекодировать” или “Выкл”.	27
		DRC	Настройка параметра “DRC” (компрессия динамического диапазона).	27
 Информация о системе		Отображение версии программного обеспечения и MAC-адреса (стр. 35).	27	

■ Пример выполнения операции с помощью меню УСТАНОВКИ

Для выполнения настроек проигрывателя необходимо вывести на экран меню УСТАНОВКИ. Ниже приведены пояснения, касающиеся основных операций с меню УСТАНОВКИ.

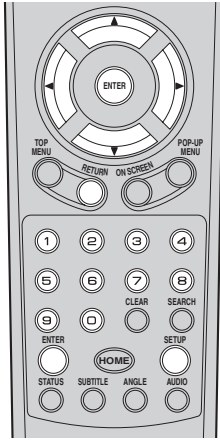

Пример: настройка параметра “Родительский контроль”

Примечание

- Настройку некоторых элементов не удастся выполнить во время воспроизведения. В этом случае дважды нажмите **■**, чтобы полностью остановить воспроизведение, и переходите к настройкам.

1. Отображение экрана меню УСТАНОВКИ.

Нажмите **SETUP** для отображения экрана меню УСТАНОВКИ.

С помощью кнопок **◀/▶** выберите элемент “Общие установки”, а затем нажмите кнопку **ENTER** или **▼**.

2. Выберите подменю.

С помощью кнопок **▲/▼** выберите элемент “Безопасность”, а затем нажмите кнопку **ENTER** или курсорную кнопку **▶**.

3. Выберите элемент меню.

С помощью кнопок **▲/▼** выберите элемент “Родительский контроль”, а затем нажмите кнопку **ENTER** или курсорную кнопку **▶**.

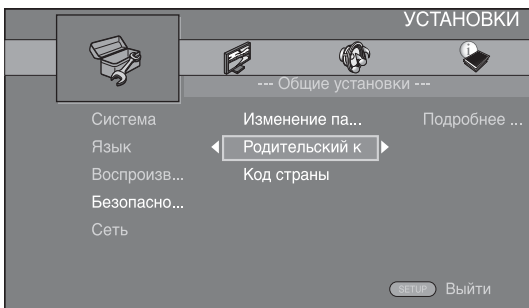

4. Введите пароль.

- Введите пароль с помощью цифровых кнопок.
- Паролем по умолчанию является 0000.
- Переход к следующему экрану установки невозможен без ввода правильного пароля.
- Чтобы изменить пароль, см. раздел “Изменение пароля” (стр. 25).

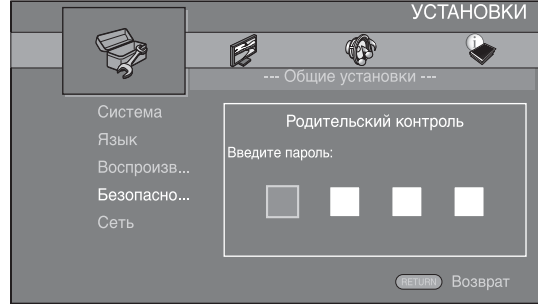

5. Выберите следующий элемент.

С помощью кнопок **▲/▼** выберите уровень параметра “Родительский контроль” для диска Blu-ray Disc/DVD и нажмите кнопку **ENTER**.

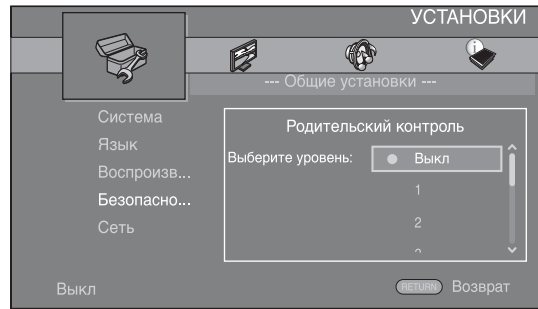

6. Закройте экран меню.

Нажмите **◀**, чтобы вернуться в предыдущее меню.

■ Общие установки

Установки по умолчанию обозначены символом “*”.

Система

Сохранение экрана

Можно включить или выключить хранитель экрана. Если эта функция включена, проигрыватель перейдет в режим сохранения экрана, если в течение 3 минут не будет выполнено ни одного действия. Если после этого в течение 27 минут не будет выполнено ни одного действия, проигрыватель перейдет в режим ожидания.

Вкл*, Выкл

Автоматическое воспроизведение дисков

Включение или выключение режима “Автоматическое воспроизведение дисков”. Если эта функция включена, диск автоматически будет воспроизведен после загрузки.

Вкл*, Выкл

HDMI контроль

Можно настроить проигрыватель для получения управляющего сигнала от телевизора или аудио/видео ресивера, совместимого с функцией “HDMI контроль”, с помощью кабеля HDMI (стр. 10).

Вкл, Выкл*

Использование функции “HDMI контроль”

Используя функцию “HDMI контроль”, можно в интерактивном режиме управлять данным проигрывателем с помощью телевизора (поддерживающего функцию “HDMI контроль”). Подключив с помощью кабеля HDMI проигрыватель к телевизору, поддерживающему функцию “HDMI контроль”, и включив функцию “HDMI контроль” в меню УСТАНОВКИ (стр. 24), можно использовать перечисленные ниже функции.

- Функция автоматического выбора входного сигнала
В случае начала воспроизведения на данном проигрывателе, селектор входов телевизора (и аудио/видео ресивера, если проигрыватель подключен к телевизору через аудио/видео ресивер) автоматически переключается на проигрыватель. В зависимости от телевизора подача питания может включаться автоматически.
- Функция автоматического выключения питания
В случае выключения телевизора в то время, когда проигрыватель находится в режиме остановки и на экране не отображается меню УСТАНОВКИ, питание проигрывателя отключается автоматически.

Примечания

- В зависимости от телевизора могут наблюдаться отклонения в работе функции “HDMI контроль”.
- Работа других функций, кроме указанных, зависит от телевизора или аудио/видео ресивера.
- Чтобы сделать доступной функцию “HDMI контроль”, выполните настройку функции “HDMI контроль” на ВСЕХ компонентах (данный проигрыватель, телевизор и аудио/видео ресивер). Может потребоваться выполнить некоторые операции.
- В зависимости от телевизора, каждая функция может быть настроена на самостоятельную активацию/деактивацию.
- Для получения более подробной информации по установке обратитесь к руководству пользователя для телевизора и/или аудио/видео ресивера.
- При включении функции потребление питания в режиме ожидания возрастает в результате работы функции “HDMI контроль”.

Загрузка исходных параметров

Можно сбросить все настройки проигрывателя к значениям по умолчанию, кроме настроек параметра “Безопасность” (стр. 25). Для получения дополнительной информации о настройках по умолчанию см. стр. 21–27.

Обновление программного обеспечения

Можно вручную обновить программное обеспечение с USB устройства или с сети Network. Для получения дополнительной информации об обновлении программного обеспечения см. раздел “Обновление программного обеспечения” (стр. 30).

Простая установка

Выполнение процедуры “Простая установка” (стр. 12).

Запоминающее устройство

Отображение информации об устройстве “Запоминающее устройство”, форматирование устройства “Запоминающее устройство” и выбор значения “Передний USB вход” или “Задний USB вход” для сохранения данных BD-Live. Чтобы выполнить форматирование (очистить) папку “BUDA” на устройстве памяти USB, выберите пункт “Информация”, а затем нажмите кнопку **ENTER**, выделив на экране элемент “Форматировать”.

Передний USB вход, Задний USB вход*

Совет

- Запоминающее устройство используется в качестве вспомогательной памяти при воспроизведении диска Blu-ray Disc.

Сообщение о 3D воспроизведении

Можно включить или отключить предупреждающее сообщение, касающееся воспроизведения видео в формате 3D, которое появляется на экране телевизора при включении проигрывателя.

Вкл*, Выкл

Язык

Экранное меню

Можно выбрать язык экранного меню, на котором будут отображаться сообщения или меню на экране, например, меню УСТАНОВКИ.

Русский, Français, Español, Deutsch, Italiano, Svenska, Nederlandse, Русский, 中文

Меню диска

Можно установить приоритетный язык для меню диска.

Русский, Français, 中文, Español, Deutsch, Italiano, Nederlandse, Португальский, Датский, Svenska, Финский, Норвежский, Русский, Корейский, Японский, Больше

Аудио

Можно установить приоритетный язык звучания для воспроизведения диска Blu-ray Disc/DVD. Для получения дополнительной информации о настройке элементов меню см. раздел “Меню диска” (стр. 24).

Субтитры

Можно установить приоритетный язык для Субтитры.

Русский, Français, 中文, Español, Deutsch, Italiano, Nederlandse, Португальский, Датский, Svenska, Финский, Норвежский, Русский, Корейский, Японский, Больше, Выкл

(Значение по умолчанию в меню [Язык] зависит от модели устройства.)

Воспроизведение

Угловая метка

Позволяет включать и выключать режим “Угловая метка” () при воспроизведении диска Blu-ray Disc/DVD, записанного с разными углами зрения.

Вкл*, Выкл

PIP метка

Позволяет включать и выключать режим “PIP метка” () при воспроизведении диска Blu-ray Disc с функцией “Картинка в картинке” (стр. 20).

Вкл*, Выкл

Метка вторичного аудио

Позволяет включать и выключать режим “Метка вторичного аудио” () при воспроизведении диска Blu-ray Disc, записанного с дополнительной звуковой дорожкой.

Вкл*, Выкл

Последняя память

Проигрыватель запоминает место на диске, где было остановлено воспроизведение последнего файла, при переходе в режим ожидания или в случае открытия лотка диска.

Вкл*, Выкл

Примечание

– Некоторые диски не поддерживают данную функцию.

Безопасность

Изменение пароля

Установка пароля для изменения уровня параметра “Родительский контроль” и значения параметра “Код страны”. См. раздел “Родительский контроль” (стр. 25) и “Код страны” (стр. 25).

Примечания

- Паролем по умолчанию является 0000.
- Если вы забыли пароль, обратитесь к разделу “Устранение неисправностей” (стр. 31) и восстановите для параметров “Безопасность” значения по умолчанию.

Родительский контроль

На некоторых дисках Blu-ray/DVD уровень контроля для просмотра диска устанавливается в зависимости от возраста зрителя. Можно установить для параметра “Родительский контроль” значение, показанное на экране, в зависимости от содержимого диска. Пароль (см. раздел “Изменение пароля” на стр. 25) необходимо ввести до установки уровня параметра “Родительский контроль”. После установки параметра “Родительский контроль” при воспроизведении диска, уровень параметра “Родительский контроль” для которого выше установленного, а также при попытке изменить уровень параметра “Родительский контроль” отобразится диалоговое окно с предложением ввести пароль.

Выкл*, 1–8

Код страны

Можно установить значение для параметра “Код страны”. Пароль (см. раздел “Изменение пароля” на стр. 25) необходимо ввести до установки параметра “Код страны”. Эти настройки можно использовать для оценки параметра “Родительский контроль” и воспроизведения диска.

Сеть

Подключение к Интернет

Установите для этого элемента значение “Разрешать” при использовании BD-Live (стр. 20), DLNA (стр. 15), при обновлении программного обеспечения по сети (стр. 30) и выполнении других функций по сети.

Разрешать*, Выключать

Информация

Можно отобразить экран с информацией о сети. На этом экране можно просмотреть следующую информацию: интерфейс (Ethernet), Тип адреса, IP адрес, Маска подсети, Основной шлюз и DNS.

Проверка соединения

Выполнение проверки подключения к Интернету. В случае неудачного результата проверки см. раздел “Настройка IP” (стр. 25) и повторите проверку.

Настройка IP

Можно настроить параметры сети.

- Авто*** Выбор автоматической настройки параметров сети для проигрывателя с помощью сервера DHCP.
- Вручную** Выбор настройки параметров сети (IP адрес, Маска подсети, Основной шлюз и DNS) вручную.

Советы

- **Цифровые клавиши** Ввод символов.
-  Перемещение цветового выделения.
- **CLEAR** Удаление символа.
- **ENTER** Сохранение настроек и выход из меню.

BD-Live соединения

Можно установить ограничение доступа к содержимому BD-Live.

Разрешенное Все диски с поддержкой BD-Live могут подключаться к сети.

Частичное Разрешенное* Разрешены только диски с сертификацией владельца.

Запрещенные Всем дискам с поддержкой BD-Live запрещено подключаться к сети.

DLNA

Можно установить для параметра DLNA (стр. 34) значения “Разрешать” или “Выключать”. Если функция DLNA не используется, установите значение “Выключать”.

Разрешать*, Выключать

Настройки прокси-сервера

Выполнение процедуры “Настройки прокси-сервера”. Для обычного использования выберите значение “Выключать”. Для настройки прокси-сервера установите значение “Разрешать”.

Разрешать Включение прокси-сервера и порта прокси-сервера.

Выключать* Прокси-сервер будет выключен. Выберите этот элемент, если прокси-сервер не используется.

Прокси-сервера Выполняются настройки прокси-сервера.

Порт прокси Выполнение настроек порта прокси-сервера.

■ Настройка дисплея

Установки по умолчанию обозначены символом “* ”.

TV

3D Выход

Можно выбрать вывод видеоизображения в формате 3D или 2D с помощью проигрывателя.

Авто* Проигрыватель автоматически выбирает видеоизображения в формате 3D или 2D.

Выкл Проигрыватель всегда выбирает видеоизображения в формате 2D.

Примечание

- Даже если для параметра “3D Выход” задано значение “Авто” и воспроизводится диск Blu-ray 3D, проигрыватель выбирает изображения в формате 2D в зависимости от соединения и настройки телевизора, и т.д. (стр. 10).

ТВ экран

Можно установить соотношение сторон экрана подключенного телевизора и отрегулировать выводимое изображение.

В случае замены телевизора (например, из-за покупки нового) и изменения соотношения сторон экрана подключенного телевизора необходимо изменить настройки параметра “ТВ экран”.



16:9 Full Выберите это значение, если проигрыватель подключен к телевизору с экраном 16:9. При воспроизведении видео с соотношением сторон экрана 4:3 видео отображается следующим образом.

16:9 Normal* Выберите это значение, если проигрыватель подключен к телевизору с экраном 16:9. При воспроизведении видео с соотношением сторон экрана 4:3 видео отображается следующим образом.

4:3 Pan Scan Выберите это значение, если проигрыватель подключен к телевизору с экраном 4:3. При воспроизведении видео с соотношением сторон экрана 16:9 видео отображается следующим образом.

4:3 Letter Box Выберите это значение, если проигрыватель подключен к телевизору с экраном 4:3. При воспроизведении видео с соотношением сторон экрана 16:9 видео отображается следующим образом.

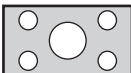
Истинный размер изображения	На телевизоре 16:9 (широкоэкранный)	
	16:9 Full	16:9 Normal
 4:3		

Истинный размер изображения	На телевизоре 4:3	
	4:3 Pan Scan	4:3 Letter Box
 16:9		

Выбор видео выхода

Для разрешения видеовыхода можно выбрать значения “Авто”, “480i/576i”, “480p/576p”, “720p”, “1080i” и “1080p”. При выборе значения “Авто” устанавливается максимальное разрешение в соответствии с подключенным телевизором. Для получения дополнительной информации о форматах вывода см. раздел “Форматы видеовыходов” (стр. 29).

Авто*, 480i/576i, 480p/576p, 720p, 1080i, 1080p

Примечание

- Для вывода аудиоформата HD (например, Dolby TrueHD или DTS-HD Master Audio) с разъема HDMI установите для параметра “Выбор видео выхода” значение “Авто” или значение выше, чем 720p.

ТВ система

Для параметра “ТВ система” можно установить значение “PAL”, “NTSC” и “Мультисистемный”. Выберите значение параметра “ТВ система” в соответствии с используемым телевизором. Для получения дополнительной информации о форматах вывода см. раздел “Форматы видеовыходов” (стр. 29).

NTSC, PAL, Мультисистемный

(Значение по умолчанию зависит от модели устройства.)

Цветовое пространство

Настройки параметра “Цветовое пространство” (стр. 35) можно выбрать в меню “HDMI”. Эта функция доступна, если проигрыватель подключен с помощью кабеля HDMI.

YCbCr 4:4:4* Установите для параметра “Цветовое пространство” значение “YCbCr 4:4:4”.

YCbCr 4:2:2 Установите для параметра “Цветовое пространство” значение “YCbCr 4:2:2”.

Full RGB Если при выборе значения “RGB” черные и белые тона на экране слишком блеклые, выберите этот элемент. Данный параметр работает, когда подключенный компонент поддерживает диапазон RGB 0–255.

RGB Видеосигнал выводится в нормальном диапазоне сигналов.

Примечание

- Эта функция доступна, только если телевизор поддерживает эту функцию.

HDMI Deep Color

Если телевизор и/или аудио/видео ресивер совместим с функцией “Deep Color” (стр. 34), выберите этот элемент в соответствии с телевизором или аудио/видео ресивером. Эта функция доступна, если проигрыватель подключен с помощью кабеля HDMI.

30 bits, 36 bits, 48 bits, Выкл*

HDMI 1080p 24Hz

При этом сигнал BD-Видео будет выводиться с частотой кадров 24 Hz в режиме HDMI 1080p 24Hz. С помощью этой функции воспроизведение видео будет более сглаженным. Эта функция доступна, если телевизор или аудио/видео ресивер поддерживает ее, и если проигрыватель подключен с помощью кабеля HDMI. Для получения дополнительной информации о форматах вывода см. раздел “Форматы видеовыходов” (стр. 29).

Авто*, Выкл

Примечание

- Если установлено другое разрешение, кроме 1080p, этот параметр будет отключен.

Lip Sync

Установка/настройка функции “Lip Sync” (стр. 35).

Авто*	Проигрыватель выполняет настройку функции “Lip Sync” автоматически.
Вручную	Можно настроить функцию “Lip Sync” вручную. Можно задать задержку аудиосигнала для содержимого в формате 2D и 3D независимо. 2D 3D
Выкл	Проигрыватель не выполняет настройку функции “Lip Sync” автоматически.

Видео обработка

Режим видеосъемки

Ниже можно выбрать значение параметра “Режим видеосъемки”.

Стандартный*	Изображение наиболее естественное и хорошо сбалансировано. Данный режим подходит для обычного использования.
Яркий	Изображение более яркое и резкое.
Кинотеатр	Подходит для просмотра фильма в темной комнате.
Обычай	Можно настроить видимое изображение вручную. С помощью кнопок ▲/▼ выберите данный параметр, а затем нажмите ◀/▶, чтобы установить значение.
Яркость	Используется для настройки общего уровня яркости изображения.
Насыщенность	Настройка сочности цвета изображения на экране.
Оттенок	Настройка тона изображения на экране.
Контрастность	Используется для настройки ярких областей (уровней белого) в изображении.
Резкость	Регулировка резкости объектов видеозображения.

СТ1

Смягчение краев цветных изображений. Отрисовка цветных изображений становится более отчетливой.

По умолчанию установлено значение 0.

Color Adjust

Настройка параметров “Яркость”, “Насыщенность” и “Оттенок” для каждого цвета (Красный/Зеленый/Синий/Желтый/Супер/Пурпурный). Для использования этой функции установите для параметра “Режим видеосъемки” значение “Обычай”. Для получения дополнительной информации о настройке элементов меню см. раздел “Режим видеосъемки” (стр. 27).

По умолчанию установлено значение 0.

Шумоподавление

Для параметра “Шумоподавление” можно установить уровень от 0 до 3, 0 соответствует значению “выключено”, а 3 - максимальному уровню.

0, 1, 2*, 3

Режим деинтерлейсинга

Выбор способа обнаружения видеосигнала. Для обычного использования выберите значение “Авто”. Если на экране появляются помехи в виде горизонтальных полос, установите для данного параметра значение “Пленка” или “ВИДЕО”.

Авто*, Пленка, ВИДЕО

Настройка звука

Установки по умолчанию обозначены символом “*”.

Аудиовыход

HDMI

Можно выбрать режим вывода разъема HDMI. Для получения дополнительной информации о форматах вывода см. раздел “Форматы аудиовыходов” (стр. 28).

Bitstream*, PCM, Перекодировать, Выкл

Примечание

- Для вывода аудиоформата HD (например, Dolby TrueHD или DTS-HD Master Audio) с разъема HDMI установите для параметра “Выбор видео выхода” значение “Авто” или значение выше, чем “720p” (стр. 26).

DRC

Можно установить для параметра “DRC” (компрессия динамического диапазона) (стр. 34) значения “Вкл”, “Выкл” или “Авто”. При установке значения “Авто” параметр DRC включается автоматически для источника с информацией DRC в формате Dolby TrueHD. Параметр DRC уменьшает громкость чрезмерно громких звуков, таких как взрывы, и повышает громкость диалогов. Это удобно при просмотре фильмов в ночное время.

Выкл, Вкл, Авто*

Информация о системе

Отображение версии программного обеспечения и MAC-адреса (стр. 35).

■ Форматы аудиовыходов

Формат источника	HDMI		
	Bitstream	PCM	Перекодировать
2-канальный PCM	с поддержкой ВА* или ЗНК**	2-канальный PCM	
	без поддержки ВА* или ЗНК**	2-канальный PCM	
5.1-канальный PCM	с поддержкой ВА* или ЗНК**	5.1-канальный PCM	
	без поддержки ВА* или ЗНК**	5.1-канальный PCM	
7.1-канальный PCM	с поддержкой ВА* или ЗНК**	7.1-канальный PCM	
	без поддержки ВА* или ЗНК**	7.1-канальный PCM	
Dolby Digital	с поддержкой ВА* или ЗНК**	Dolby Digital	До 5.1-канального PCM
	без поддержки ВА* или ЗНК**		Dolby Digital
Dolby Digital Plus	с поддержкой ВА* или ЗНК**	Dolby Digital Plus	До 7.1-канального PCM
	без поддержки ВА* или ЗНК**		Dolby Digital Plus
Dolby TrueHD	с поддержкой ВА* или ЗНК**	Dolby TrueHD	До 7.1-канального PCM
	без поддержки ВА* или ЗНК**		Dolby TrueHD
DTS	с поддержкой ВА* или ЗНК**	DTS	До 5.1-канального PCM
	без поддержки ВА* или ЗНК**		DTS
DTS HD High Resolution	с поддержкой ВА* или ЗНК**	DTS HD High Resolution	До 5.1-канального PCM
	без поддержки ВА* или ЗНК**		(Core decode) DTS HD High Resolution
DTS-HD Master Audio	с поддержкой ВА* или ЗНК**	DTS-HD Master Audio	До 5.1-канального PCM
	без поддержки ВА* или ЗНК**		(Core decode) DTS DTS-HD Master Audio

* “ВА” обозначает “вторичное аудио”.

** “ЗНК” обозначает “звук нажатия кнопки”, т.е. звуковой эффект для всплывающих окон и т.д.

Примечания

- При установке для параметра “HDMI” значения “Bitstream” дополнительная звуковая дорожка не воспроизводится (стр. 27).
- Для вывода аудиоформата HD (например, Dolby TrueHD или DTS-HD Master Audio) с разъема HDMI установите для параметра “Выбор видео выхода” значение “Авто” или значение выше, чем “720p” (стр. 26).

■ Форматы видеовыходов

Для параметра “ТВ система” установлено значение “NTSC”

	Разрешение	Авто	480i/576i	480p/576p	720p	1080i	1080p
HDMI	BD-Video с содержимым 1080p/24 Hz	*1, *2	480i	480p	720p 60 Hz	1080i 60 Hz	1080p 24/60 Hz *2
	Прочее						1080p 60 Hz

Для параметра “ТВ система” установлено значение “PAL”

	Разрешение	Авто	480i/576i	480p/576p	720p	1080i	1080p
HDMI	BD-Video с содержимым 1080p/24 Hz	*1, *2	576i	576p	720p 50 Hz	1080i 50 Hz	1080p 24/50 Hz *2
	Прочее						1080p 50 Hz

*1 Установлено максимальное разрешение, поддерживаемое подключенным телевизором. Например, если максимальное разрешение, поддерживаемое подключенным телевизором, составляет 1080p, будет установлено разрешение 1080p.

*2 Если с источника выводится содержимое в формате 1080p 24 Hz, и подключенный телевизор поддерживает вывод содержимого в формате 1080p 24 Hz, вместо сигнала 1080p 50/60 Hz будет выводиться сигнал 1080p 24 Hz при выборе разрешения “Авто” или “1080p” и установке значения “Авто” для параметра “HDMI 1080p 24Hz” (стр. 27) в меню “Настройка дисплея”.

Для параметра “ТВ система” установлено значение “Мультисистемный”

При установке для параметра “ТВ система” значения “Мультисистемный” видеосигнал выводится с частотой сигнала источника. Для получения дополнительной информации о параметрах частоты телевизора и разрешении выходного видеосигнала см. таблицу выше.

Примечания

- Если установлено другое разрешение, кроме 1080p, параметр HDMI 1080p 24Hz будет отключен.
- Если для параметра “ТВ система” установлено значение “NTSC”, но частота источника видео не соответствует значению 60 Hz, видеосигнал на выходе будет преобразован в сигнал с частотой 60 Hz.
- Если для параметра “ТВ система” установлено значение “PAL”, но частота источника видео не соответствует значению 50 Hz, видеосигнал на выходе будет преобразован в сигнал с частотой 50 Hz.

Обновление программного обеспечения

Некоторые из недавно выпущенных дисков Blu-ray не могут быть воспроизведены до тех пор, пока не будет установлена последняя версия программного обеспечения проигрывателя. Рекомендуется провести обновление программного обеспечения проигрывателя с помощью функции обновления программного обеспечения, чтобы использовать проигрыватель в соответствии с последней версией программного обеспечения.

Проверить наличие обновления программного обеспечения можно по адресу:
<http://download.yamaha.com/>

Примечание

- Не извлекайте устройство памяти USB, не переводите проигрыватель в режим ожидания и не отсоединяйте кабель питания/кабель LAN во время обновления программного обеспечения.

■ Обновление программного обеспечения

- ③ Выберите элемент, в котором содержится файл с пакетом обновления, с USB устройства или с сети Network.

1. Выполните подготовку к обновлению программного обеспечения.

При обновлении программного обеспечения с USB устройства:

- ① Сохраните файл с пакетом обновления в соответствующую папку на устройстве памяти USB. Для получения дополнительной информации см. инструкцию, прилагаемую к файлу с пакетом обновления.

- ② Подключите устройство памяти USB. Выполнять шаг 2 не требуется.

При обновлении программного обеспечения с сети Network:

Убедитесь, что проигрыватель подключен к сети.

2. Выберите способ обновления и запустите обновление в меню УСТАНОВКИ.

- ① Нажмите **SETUP** для отображения экрана меню УСТАНОВКИ.
- ② Выберите “Общие установки” → “Система” → “Обновление программного обеспечения”.

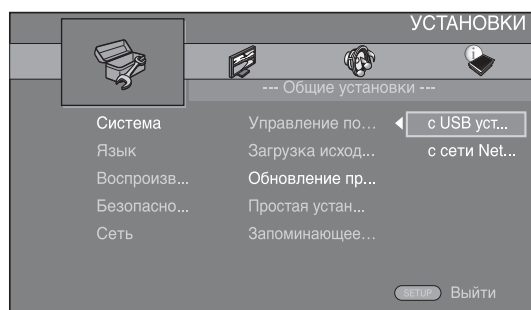

Система выполнит поиск файла с пакетом обновления.

3. Выполните обновление программного обеспечения, следуя указаниям на экране.

Обновление завершено. Система будет перезапущена.





Устранение неисправностей

Если проигрыватель функционирует неправильно, обратитесь к приведенной ниже таблице. В случае, если проблема не указана в таблице или проблему не удалось устранить, выключите проигрыватель, отсоедините силовую кабель и обратитесь к ближайшему авторизованному дилеру или в сервисный центр Yamaha.

■ Питание

Неисправность	Вероятная причина и методы устранения
Нет питания.	<ul style="list-style-type: none"> – Правильно подсоедините прилагаемый кабель питания переменного тока. – Нажмите кнопку  на передней панели, чтобы включить питание.
Питание проигрывателя выключается.	<ul style="list-style-type: none"> – Питание будет автоматически выключаться через 30 минут непрерывного бездействия (отсутствия воспроизведения).

■ Основные операции

Неисправность	Вероятная причина и методы устранения
Пульт дистанционного управления не работает.	<ul style="list-style-type: none"> – Используйте пульт дистанционного управления в пределах его рабочего диапазона. (стр. 9) – Замените батарейки. (стр. 9)
Кнопки не работают.	<ul style="list-style-type: none"> – Нажмите и удерживайте кнопку  на передней панели более 5 секунд, а затем отпустите, чтобы сбросить настройки проигрывателя (системный сброс). – Для полной перезагрузки проигрывателя отсоедините кабель питания от сети переменного тока на 10 секунд или более, затем снова подсоедините его и включите проигрыватель.
Пароль забыт.	<ul style="list-style-type: none"> – Одновременно нажмите и удерживайте кнопки   и  на передней панели, если диск не вставлен и воспроизведение остановлено, чтобы сбросить все настройки проигрывателя, в том числе настройки Безопасность (стр. 25), и восстановить значения по умолчанию. После автоматического выключения питания нажмите кнопку  для его повторного включения.

■ Воспроизведение диска

Неисправность	Вероятная причина и методы устранения
Диск не воспроизводится в проигрывателе.	<ul style="list-style-type: none"> – Извлеките диск и очистите его. (стр. 4) – Убедитесь, что диск правильно введен (ровно лежит в лотке, этикеткой вверх). (стр. 4) – Используйте диск, поддерживаемый проигрывателем. (стр. 3) – Извлеките диск и проверьте, поддерживаются ли такие диски проигрывателем. (стр. 3) – Проверьте региональный код. (стр. 3) – Проверьте диск на предмет дефектов, установив другой диск. – Диски CD-R/RW, DVD+R/RW/R DL и DVD-R/RW/R DL должны быть финализированы. (стр. 3)
Видео останавливается.	<ul style="list-style-type: none"> – Проигрыватель прекращает воспроизведение в случае толчка или вибрации.
Проигрыватель издает щелчок в момент начала воспроизведения или загрузки диска.	<ul style="list-style-type: none"> – Данные звуки не указывают на неисправность проигрывателя и являются обычными условиями работы.

■ Изображение

Неисправность	Вероятная причина и методы устранения
Отсутствует изображение.	<ul style="list-style-type: none"> – Убедитесь, что кабель HDMI подключен правильно. (стр. 10) – Убедитесь, что для подключаемого телевизора или аудио/видео ресивера установлен правильный вход. (стр. 10) – Извлеките диск или остановите воспроизведение, затем одновременно нажмите и удерживайте кнопки ► и ■ на передней панели, чтобы восстановить значения разрешения видео по умолчанию. Если после этого вывод изображения все еще невозможен, нажмите и удерживайте кнопку ■ на передней панели в течение приблизительно 5 секунд, чтобы переключиться между режимами NTSC/PAL.
Изображение на экране застыло и кнопки управления не функционируют.	<ul style="list-style-type: none"> – Нажмите ■, затем повторите запуск воспроизведения. – Выключите питание и снова включите его. – Нажмите и удерживайте кнопку ⏻ на передней панели более 5 секунд, а затем отпустите, чтобы сбросить настройки проигрывателя.
Разрешение выводимого видео не соответствует требуемому.	<ul style="list-style-type: none"> – Установите требуемое разрешение. (стр. 26)
Широкоэкранное изображение растянуто по вертикали, либо на экране присутствуют черные полосы вверху и внизу. Либо видео с соотношением 4:3 вытянуто по горизонтали.	<ul style="list-style-type: none"> – Измените соотношение сторон экрана телевизора. (стр. 26)
На экране появляются помехи в виде квадратов (мозаика).	<ul style="list-style-type: none"> – Блоки в изображениях могут быть видны в эпизодах с быстрым движением из-за характеристик технологии сжатия цифрового изображения.
Звук не выводится или изображение не воспроизводится надлежащим образом.	<ul style="list-style-type: none"> – Звук может не выводиться и изображения могут не воспроизводиться надлежащим образом для некоторых дисков, содержание которых защищено авторским правом.

■ Звук

Неисправность	Вероятная причина и методы устранения
Звук отсутствует или искажен.	<ul style="list-style-type: none"> – Убедитесь, что кабель HDMI подключен правильно. (стр. 10) – Увеличьте уровень громкости телевизора или аудио/видео ресивера. – Звук будет отсутствовать в режиме стоп-кадра и ускоренного перехода вперед и назад. (стр. 8) – Звук может не выводиться в зависимости от состояния записи, например в случае записи сигнала, отличного от звукового, или нестандартного сигнала в качестве звукового сопровождения диска. (стр. 3)
Левый и правый каналы звука заменены местами, либо звук воспроизводится только с одной стороны.	<ul style="list-style-type: none"> – Проверьте подключение HDMI. (стр. 10)
Звук не выводится или изображение не воспроизводится надлежащим образом.	<ul style="list-style-type: none"> – Звук может не выводиться и изображения могут не воспроизводиться надлежащим образом для некоторых дисков, содержание которых защищено авторским правом.
Не слышен звук при использовании функции PIP (вторичное аудио).	<ul style="list-style-type: none"> – Установите для параметра HDMI значение PCM/Перекодировать. (стр. 27) – Для прослушивания вторичного аудио нажмите кнопку 2ND AUDIO. (стр. 6) – В зависимости от диска, возможно, потребуется включить параметр вторичного аудио в главном меню диска. (стр. 8)

■ Сеть

Неисправность	Вероятная причина и методы устранения
Не устанавливается соединение с Интернетом.	<ul style="list-style-type: none"> – Правильно подсоедините сетевой кабель. – Включите подсоединенное оборудование, например, широкополосный маршрутизатор или модем. – Правильно подключите широкополосный маршрутизатор и/или модем. – Установите надлежащие значения в настройках сети. Проверьте параметр “Сеть”. (стр. 25)
Не удается загрузить содержимое BD-Live.	<ul style="list-style-type: none"> – Правильно подсоедините сетевой кабель. (стр. 11) – Правильно подсоедините устройство памяти USB. Убедитесь, что устройство памяти USB подключено к разьему USB проигрывателя. (стр. 11) – Убедитесь, что диск Blu-ray Disc поддерживает функцию BD-Live. – Проверьте настройки параметра “Подключение к Интернет”. (стр. 25) – Подключите устройство памяти USB, отформатированное в файловой системе FAT16, FAT32 или NTFS. – Рекомендуется подключать устройства памяти USB с объемом свободного пространства не менее 2 Гб. Если свободного пространства недостаточно, выполните форматирование устройства памяти USB. (стр. 24) – Обратитесь к руководству пользователя, прилагаемому к диску, или проконсультируйтесь с производителем диска.
Не удается обнаружить сервер DLNA.	<ul style="list-style-type: none"> – Правильно подсоедините сетевой кабель. – Включите подсоединенное оборудование, например, широкополосный маршрутизатор или сервер. – Убедитесь, что проигрыватель и сервер подключены к одной точке доступа. – Установите надлежащие значения в настройках сети. Проверьте параметр “Сеть”. (стр. 25) – В зависимости от сервера DLNA, возможно, потребуется разрешить на сервере доступ проигрывателю. – В зависимости от сервера DLNA, может потребоваться изменить настройки межсетевое экрана.
Не удается воспроизвести файл на сервере домашней сети.	<ul style="list-style-type: none"> – Убедитесь, что файл можно воспроизвести. (стр. 3) – Проверьте настройки сервера DLNA. – Качество воспроизведения и работы может зависеть от условий домашней сети.

■ Сообщения на экране

- При воспроизведении неподходящего диска или при возникновении ошибки во время работы на экране телевизора будут появляться следующие сообщения.

Сообщение об ошибке	Вероятная причина и методы устранения
Неподдерживаемый файл	– Файл не поддерживается проигрывателем. См. раздел “Типы дисков/файлов, которые можно использовать с этим проигрывателем” (стр. 3).
Неправильный код региона!	– Несовместимый региональный код диска. См. раздел “Информация о выборе региона для видеоформата Blu-ray Disc/DVD” (стр. 3).
Ошибка сети.	– Не удается подключить проигрыватель к сети. Проверьте настройки подключения (стр. 11) и сети (стр. 25).
Сеть ОК, ошибка прокси сервера.	– Не удается подключить проигрыватель к прокси-серверу. См. раздел “Настройки прокси-сервера” (стр. 26).
Подключение BD-live запрещено в меню УСТАНОВКИ.	– BD-Live соединения запрещены. См. раздел “BD-Live соединения” (стр. 25).
Обновление не удалось по ряду причин!	– Ошибка обновления. Убедитесь, что файл обновления не поврежден и доступен для чтения.

Глоссарий

AVCHD

AVCHD — это новый формат (стандарт) для видеокамер высокого разрешения, которые могут быть использованы для записи и воспроизведения изображения HD с высоким разрешением.

BD-Live™

BD-Live является стандартом Blu-ray Disc, использующим сетевое подключение, и позволяет выходить в сеть с помощью проигрывателя и загружать рекламные видеоролики и другие данные.

BDMV

BDMV (фильм Blu-ray Disc) представляет собой один из форматов приложения, используемый для дисков BD-ROM и являющийся одной из технических характеристик диска Blu-ray Disc. BDMV является форматом записи, эквивалентным формату DVD-Video технических характеристик DVD.

Blu-ray 3D™

Функция Blu-ray 3D позволяет просматривать полноразмерные изображения высокой четкости в формате 3D.

BONUSVIEW™

При использовании дисков с поддержкой BONUSVIEW можно одновременно воспроизводить дополнительный видеоканал для двух экранов, дополнительный аудиоканал и субтитры. Во время воспроизведения на основном экране отображается небольшой дополнительный экран (картинка в картинке).

Deep Color

Deep Color означает использование различной глубины цвета на дисплеях по сравнению с глубиной в 24 бита в предыдущих версиях технических характеристик HDMI. Дополнительная битовая глубина позволяет телевизорам высокой четкости и другим дисплеям отображать не миллионы, а миллиарды цветов, а также устранять цветовые полосы на экране и обеспечивать плавные тональные переходы и тонкие градации цветов. Увеличенная контрастность позволяет отобразить гораздо больше оттенков серого в переходе от черного цвета к белому. Кроме того, Deep Color увеличивает число возможных цветов в пределах границ, определяемых цветовым пространством RGB или YCbCr.

DLNA

Стандарт DLNA (Digital Living Network Alliance) предназначен для удобной передачи цифрового медиасодержимого по домашней сети, и с помощью этого проигрывателя на телевизоре можно воспроизводить цифровое содержимое, хранящееся на компьютере с установленным программным обеспечением для поддержки серверов DLNA или другом DLNA-совместимом устройстве. Чтобы подключить проигрыватель к серверу DLNA, необходимо выполнить ряд настроек сервера или устройства DLNA. Для получения дополнительной информации см. документацию программного обеспечения сервера DLNA или устройства DLNA.

Dolby Digital

Система звука, разработанная компанией Dolby Laboratories Inc., которая придает атмосферу кинотеатра при просмотре фильмов, в случае, если данный аппарат подключен к процессору или усилителю системы Dolby Digital.

Dolby Digital Plus

Система звука, разработанная в качестве расширения Dolby Digital. Эта технология кодирования аудио поддерживает 7.1 многоканальный объемный звук.

Dolby TrueHD

Dolby TrueHD представляет собой технологию кодирования без потерь, поддерживающую до 8 каналов многоканального объемного звука для оптических дисков нового поколения. Воспроизводимый звук с точностью до бита повторяет оригинальный источник.

DRC (управление динамическим диапазоном)

DRC позволяет регулировать диапазон между наиболее громкими и тихими звуками (динамический диапазон) для воспроизведения со средней громкостью. Используйте эту функцию, если трудно различить диалог или если при воспроизведении можно потревожить соседей.

DTS

Представляет собой систему цифрового звука, разработанную компанией DTS, Inc. для использования в кинотеатрах.

DTS-HD High Resolution Audio

DTS-HD High Resolution Audio - это новая технология, разработанная для формата нового поколения оптического диска высокой четкости.

DTS-HD Master Audio

DTS-HD Master Audio - это технология сжатия аудиосигнала без потерь, разработанная для формата нового поколения оптического диска высокой четкости.

FLAC

FLAC (Free Lossless Audio Codec) — это открытый формат файлов для сжатия аудиоданных без потерь. Несмотря на то, что по степени сжатия он уступает другим форматам сжатия аудиосигналов, качество звука при этом зачастую выше.

HDMI

HDMI (Мультимедийный интерфейс высокой четкости) представляет собой интерфейс, который поддерживает как видеосигнал, так и аудиосигнал через общее цифровое подключение. HDMI-подключение используется для вывода в цифровой форме без ухудшения качества стандартных видеосигналов и видеосигналов высокого разрешения, а также многоканальных аудиосигналов на аудио/видео устройства, такие как телевизоры, оснащенные разъемом HDMI.

Letterbox (LB 4:3)

Формат экрана с черными полосами в верхней и нижней частях изображения, позволяющий просмотр широкоэкранный материал (16:9) на подключенном телевизоре формата 4:3.

Lip Sync

Lip Sync - сокращение от “lip synchronization” (синхронизация звучания). Данный технический термин подразумевает как проблему, так и возможность синхронизации аудио- и видеосигналов на завершающем этапе создания и передаче данных. В то время как для устранения задержки аудио- и видеосигнала требуется сложная подстройка воспроизведения пользователем, версия HDMI оснащена технологией автоматической синхронизации аудио и видео, что позволяет устройствам выполнять синхронизацию автоматически без участия пользователя.

Mac-адрес

Mac-адрес – это уникальное значение, присваиваемое сетевому устройству для его идентификации.

Pan Scan (PS 4:3)

Формат экрана, который отрезает боковые стороны изображения и позволяет просмотр широкоэкранный материал (16:9) на подключенном телевизоре формата 4:3.

x.v.Color

Функция x.v.Color позволяет воспроизводить большую цветовую гамму, чем ранее, выводя практически все цвета, воспринимаемые человеческим глазом.

Звук Linear PCM

Linear PCM представляет собой формат записи сигнала, используемый для аудиодисков CD, а также некоторых дисков DVD и Blu-ray. Звук на аудиодисках CD записывается с использованием частоты 44,1 кГц и 16-битной разрядности. (Звук записывается в диапазоне частот от 48 кГц с 16-битной разрядностью до 96 кГц с 24-битной разрядностью на дисках DVD и в диапазоне от 48 кГц с 16-битной разрядностью до 192 кГц с 24-битной разрядностью на дисках Blu-ray.)

Субтитры

Представляют собой строки текста, появляющиеся в нижней части экрана, которые используются для перевода или расшифровки диалога. Они записаны на многих дисках DVD и Blu-ray.

Цветовое пространство

Цветовое пространство – это цветовая гамма, которую можно передать. RGB – это цветовое пространство на основе цветовой модели RGB (красный, зеленый и синий), которое обычно используется в компьютерных мониторах. YCbCr – это цветовое пространство на основе сигнала яркости (Y) и двух сигналов различия цвета (Cb и Cr).

Технические характеристики

■ Общая часть

Источник питания

[Модели для США и Канады].....	110–240 В переменного тока, 60 Гц
[Модель для Центральной и Южной Америки]
.....	110–240 В переменного тока, 50/60 Гц
[Модель для Австралии].....	110–240 В переменного тока, 50 Гц
[Модель для Великобритании, Европы и России]
.....	110–240 В переменного тока, 50 Гц
[Модель для Китая].....	110–240 В переменного тока, 50 Гц
[Модель для Азии].....	110–240 В переменного тока, 50/60 Гц
[Модель для Кореи].....	110–240 В переменного тока, 60 Гц
Потребляемая мощность (в обычном режиме).....	18 Вт
Потребляемая мощность (в режиме ожидания).....	0,5 Вт или меньше
Размеры (Ш × В × Г).....	435 × 50 × 202 мм
Вес.....	2,0 кг

■ Входные/выходные терминалы

Выход HDMI.....	Разъем типа A × 1 480i/576i/480p/576p/720p/1080i/1080p/1080p при 24 Гц, Deep Color, поддержка x.v. Color
USB.....	Разъем типа A × 2
Прочее оборудование.....	Ethernet × 1

Технические характеристики могут изменяться без уведомления.

■ Авторское право

- Аудиовизуальный материал может содержать работы, защищенные авторским правом, которые не должны записываться без разрешения владельца авторского права. Обратитесь к соответствующим законам вашей страны.
- Произведено по лицензии Dolby Laboratories. Название Dolby и символ с двойной буквой D являются торговыми марками Dolby Laboratories.
- Произведено по лицензии по Патентам США №: 5,956,674; 5,974,380; 6,487,535 и другим, выпущенным или ожидающим подтверждения патентам США и мировым патентам. DTS, соответствующий символ, а также DTS вместе с соответствующим символом являются зарегистрированными товарными знаками; логотипы DTS Digital Surround и DTS являются товарными знаками компании DTS, Inc. Продукт включает программное обеспечение. © DTS, Inc. Все права защищены.
- “Blu-ray Disc™”, “Blu-ray™”, “Blu-ray 3D™”, “BD-Live™”, “BONUSVIEW™” и соответствующие логотипы являются товарными знаками ассоциации Blu-ray Disc Association.
-  является товарным знаком компании DVD Format/Logo Licensing Corporation.
- “HDMI”, логотип “HDMI” и “High-Definition Multimedia Interface” являются товарными знаками или зарегистрированными товарными знаками компании HDMI Licensing LLC.
- “x.v.Color” и логотип “x.v.Color” являются торговыми марками компании Sony Corporation.
- “AVCHD” и логотип “AVCHD” являются торговыми марками компаний Panasonic Corporation и Sony Corporation.
- Java и все товарные знаки и логотипы, основанные на Java, являются товарными знаками или зарегистрированными товарными знаками Sun Microsystems, Inc. в США и/или других странах.
- Данный продукт лицензирован по лицензии на пакет патентных лицензий AVC и пакета патентных лицензий VC-1 для личного некоммерческого пользования потребителем (i) кодирования видео в соответствии со стандартом AVC и стандартом VC-1 (“AVC/VC-1 Video”), и/или (ii) декодирования AVC/VC-1 Video, которое были закодировано потребителем, занимающимся личной некоммерческой деятельностью, и/или было приобретено у поставщика видеопроизводства, имеющего лицензию на предоставление AVC/VC-1 Video. На использование в иных целях лицензия не предоставляется и не распространяется. Для дополнительных сведений обращаться в MPEG LA, LLC.
См. <http://www.mpegla.com>.
- Windows Media Player является зарегистрированным товарным знаком Microsoft Corporation в США и/или других странах.
- Логотипы YouTube и YouTube являются торговыми марками Google, Inc.
- DLNA и DLNA CERTIFIED являются товарными знаками и/или знаками обслуживания компании Digital Living Network Alliance.
- Авторское право на 2004–2010 гг. принадлежит Verance Corporation. Cinavia™ является товарным знаком компании Verance Corporation. Защищен патентом США 7369677 и другими выпущенными или ожидающими подтверждения мировыми патентами по лицензии компании Verance Corporation. Все права защищены.

Алфавитный указатель

■ ЧИСЛЕННЫЕ ЗНАЧЕНИЯ

2ND AUDIO, пульт дистанционного управления	6
3D Выход, меню УСТАНОВКИ	26
■ А	
ANGLE, пульт дистанционного управления	7
AUDIO, пульт дистанционного управления	7
A/B, пульт дистанционного управления	7
■ В	
BD-Live	20
BD-Live соединения, меню УСТАНОВКИ	25
■ С	
CLEAR, пульт дистанционного управления	7
Color Adjust, меню УСТАНОВКИ	27
■ D	
DIGEST, пульт дистанционного управления	7
DLNA, меню УСТАНОВКИ	25
DRC, меню УСТАНОВКИ	27
■ E	
ENTER, пульт дистанционного управления	7, 8
■ H	
HDMI 1080p 24Hz, меню УСТАНОВКИ	27
HDMI Deep Color, меню УСТАНОВКИ	26
HDMI контроль, меню УСТАНОВКИ	24
HDMI, меню УСТАНОВКИ	27
HOME, пульт дистанционного управления	7
■ L	
Lip Sync, меню УСТАНОВКИ	27
■ M	
MARKER, пульт дистанционного управления	6
■ O	
ON SCREEN, пульт дистанционного управления	8
■ P	
PIP метка, меню УСТАНОВКИ	25
PIP, пульт дистанционного управления	6
POP UP/MENU, пульт дистанционного управления	8
PROGRAM, пульт дистанционного управления	6
■ R	
REPEAT, пульт дистанционного управления	6
RETURN, пульт дистанционного управления	8
■ S	
SEARCH, пульт дистанционного управления	7
SETUP, пульт дистанционного управления	7
SHUFFLE, пульт дистанционного управления	6
STATUS, пульт дистанционного управления	7
SUBTITLE, пульт дистанционного управления	7
■ T	
TOP MENU, пульт дистанционного управления	8
TV, меню УСТАНОВКИ	26
■ U	
USB-подключение	11

■ Z

ZOOM, пульт дистанционного управления	7
---	---

■ А

Автоматическое воспроизведение дисков, меню УСТАНОВКИ	24
Аудиовыход, меню УСТАНОВКИ	27
Аудио, меню УСТАНОВКИ	24
Аудио, экранное меню	17

■ Б

Безопасность, меню УСТАНОВКИ	25
Битрейт, экранное меню	17

■ В

Видео обработка, меню УСТАНОВКИ	27
Воспроизведение диска с данными	13
Воспроизведение с YouTube	16
Воспроизведение содержимого носителя USB	13
Воспроизведение, меню УСТАНОВКИ	25
Время, экранное меню	17
Вторичное аудио, экранное меню	17
Вторичное видео, экранное меню	17
Выбор видео выхода, меню УСТАНОВКИ	26
Выполнение операций с помощью меню УСТАНОВКИ	23

■ Г

Глава, экранное меню	17
----------------------------	----

■ З

Заголовок, экранное меню	17
Загрузка исходных параметров, меню УСТАНОВКИ	24
Закладка	19
Запоминающее устройство, меню УСТАНОВКИ	24

■ И

Изменение пароля, меню УСТАНОВКИ	25
Информация о системе, меню УСТАНОВКИ	27
Информация, меню УСТАНОВКИ	25
Использование функции "Картинка в картинке"	20

■ К

Кнопки управления курсором, пульт дистанционного управления	8
Кнопки управления, пульт дистанционного управления	8
Код страны, меню УСТАНОВКИ	25

■ M

Мгновенный Повтор, экранное меню	17
Мгновенный Поиск, экранное меню	17
Меню HOME	13
Меню MEDIA	13
Меню диска, меню УСТАНОВКИ	24
Меню состояния	18
Меню УСТАНОВКИ	21
Меры предосторожности при обращении с диском	4
Метка вторичного аудио, меню УСТАНОВКИ	25

■ H

Настройка IP, меню УСТАНОВКИ	25
Настройка дисплея, меню УСТАНОВКИ	26
Настройка звука, меню УСТАНОВКИ	27
Настройки прокси-сервера, меню УСТАНОВКИ	26
Начальные установки	12

■ O

Обновление программного обеспечения	30
Обновление программного обеспечения, меню УСТАНОВКИ	24
Общие установки, меню УСТАНОВКИ	24

■ П

Перемещение, экранное меню	17
Подключение HDMI	10
Подключение к Интернет, меню УСТАНОВКИ	25
Последняя память, меню УСТАНОВКИ	25
Прилагаемые компоненты	2
Проверка соединения, меню УСТАНОВКИ	25
Программное воспроизведение	19
Простая установка, меню УСТАНОВКИ	12
Пульт дистанционного управления	6

■ P

Режим видеосъемки, меню УСТАНОВКИ	27
Режим деинтерлейсинга, меню УСТАНОВКИ	27
Режим/Режим воспроизведения, экранное меню	17
Родительский контроль, меню УСТАНОВКИ	25

■ C

Сетевое подключение	11
Сеть, меню УСТАНОВКИ	25
Система, меню УСТАНОВКИ	24
Слайд-шоу, экранное меню	17
Сообщение о 3D воспроизведении, меню УСТАНОВКИ	24
Сохранение экрана, меню УСТАНОВКИ	24
Стиль субтитров, экранное меню	17
Субтитры, меню УСТАНОВКИ	25
Субтитры, экранное меню	17

■ T

ТВ система, меню УСТАНОВКИ	26
ТВ экран, меню УСТАНОВКИ	26
Требование к аудиофайлу	3
Трек/Файл, экранное меню	17

■ Y

Угловая метка, меню УСТАНОВКИ	25
Угол, экранное меню	17
Устранение неисправностей	31

■ Ф

Форматы аудиовыходов	28
Форматы видеовыходов	29
Функция поиска	19
Функция "HDMI контроль"	24

■ Ц

Цветные кнопки, пульт дистанционного управления	7
Цветовое пространство, меню УСТАНОВКИ	26
Цифровые кнопки, пульт дистанционного управления	7

■ Ш

Шумоподавление, меню УСТАНОВКИ	27
--------------------------------------	----

■ Э

Экранное меню	17
Экранное меню, меню УСТАНОВКИ	24

■ Я

Язык, меню УСТАНОВКИ	24
----------------------------	----

Caution: Read this before operating your unit.

- 1 To assure the finest performance, please read this manual carefully. Keep it in a safe place for future reference.
- 2 Install this sound system in a well ventilated, cool, dry, clean place—away from direct sunlight, heat sources, vibration, dust, moisture, and/or cold. For proper ventilation, allow the following minimum clearances.
Top : 10 cm (4 in)
Rear: 10 cm (4 in)
Side: 10 cm (4 in)
- 3 Locate this unit away from other electrical appliances, motors, or transformers to avoid humming sounds.
- 4 Do not expose this unit to sudden temperature changes from cold to hot, and do not locate this unit in an environment with high humidity (i.e. a room with a humidifier) to prevent condensation inside this unit, which may cause an electrical shock, fire, damage to this unit, and/or personal injury.
- 5 Avoid installing this unit where foreign object may fall onto this unit and/or this unit may be exposed to liquid dripping or splashing. On the top of this unit, do not place:
 - Other components, as they may cause damage and/or discoloration on the surface of this unit.
 - Burning objects (i.e. candles), as they may cause fire, damage to this unit, and/or personal injury.
 - Containers with liquid in them, as they may fall and liquid may cause electrical shock to the user and/or damage to this unit.
- 6 Do not cover this unit with a newspaper, tablecloth, curtain, etc. in order not to obstruct heat radiation. If the temperature inside this unit rises, it may cause fire, damage to this unit, and/or personal injury.
- 7 Do not plug in this unit to a wall outlet until all connections are complete.
- 8 Do not operate this unit upside-down. It may overheat, possibly causing damage.
- 9 Do not use force on switches, knobs and/or cords.
- 10 When disconnecting the power cable from the wall outlet, grasp the plug; do not pull the cable.
- 11 Do not clean this unit with chemical solvents; this might damage the finish. Use a clean, dry cloth.
- 12 Only voltage specified on this unit must be used. Using this unit with a higher voltage than specified is dangerous and may cause fire, damage to this unit, and/or personal injury. Yamaha will not be held responsible for any damage resulting from use of this unit with a voltage other than specified.
- 13 To prevent damage by lightning, keep the power cable disconnected from a wall outlet or this unit during a lightning storm.
- 14 Do not attempt to modify or fix this unit. Contact qualified Yamaha service personnel when any service is needed. The cabinet should never be opened for any reasons.
- 15 When not planning to use this unit for long periods of time (i.e. vacation), disconnect the AC power plug from the wall outlet.
- 16 Be sure to read the “Troubleshooting” section on common operating errors before concluding that this unit is faulty.
- 17 Before moving this unit, press  to set this unit to the standby mode, and disconnect the AC power plug from the wall outlet.
- 18 Condensation will form when the surrounding temperature changes suddenly. Disconnect the power cable from the outlet, then leave this unit alone.
- 19 When using this unit for a long time, this unit may become warm. Turn the power off, then leave this unit alone for cooling.
- 20 Install this unit near the AC outlet and where the AC power plug can be reached easily.
- 21 The batteries shall not be exposed to excessive heat such as sunshine, fire or the like.

This unit is not disconnected from the AC power source as long as it is connected to the wall outlet, even if this unit itself is turned off by . This state is called the standby mode. In this state, this unit is designed to consume a very small quantity of power.

WARNING
TO REDUCE THE RISK OF FIRE OR ELECTRIC SHOCK, DO NOT EXPOSE THIS UNIT TO RAIN OR MOISTURE.

The laser component in this product is capable of emitting radiation exceeding the limit for Class 1.

Contents

1

1. Introduction

What you can do with this Player	2
Supplied parts	2
About discs and files	3
Types of discs/files that can be used with this Player	3
Loading a disc.....	4
Disc precautions	4
Notice for watching 3D video images	4
Cinavia technology.....	4
Controls and functions	5
Front panel.....	5
Rear panel.....	5
Remote control	6

2. Connection

HDMI connection	10
Connecting to the HDMI terminal.....	10
Connection for the playback of Blu-ray 3D Discs	10
Network and USB connection	11
Connecting to the NETWORK terminal	11
Connecting to the USB connector	11

3. Playback

Initial Wizard/Easy Setup	12
Setting with the Initial Wizard/Easy Setup.....	12
HOME/MEDIA menu	13
Playing back photo/music/video.....	13
Using network content.....	15
Using network services	16
Playing videos from YouTube™	16
Advanced playback operation	17
On Screen menu.....	17
Status menu.....	18
Using Bookmark.....	19
Program play.....	19
Using Search	19
Enjoying BONUSVIEW™ and BD-Live™.....	20
Using Picture in Picture function (secondary audio/video playback)	20
Using the feature of BD-Live™	20

4. Settings

SETUP menu	21
Example of SETUP menu operation.....	23
General Setting.....	24
Display Setting.....	26
Audio Setting	27
System Information.....	27
About the audio output formats	28
About the video output formats	29
Software upgrade	30
Upgrading the software	30

5. Additional information

Troubleshooting	31
Power	31
Basic operation.....	31
Disc playback.....	31
Picture	32
Sound	32
Network.....	33
Messages on the screen	33
Glossary	34
Specifications	35
General	35
Input/output.....	35
Copyright	36
Index	37

(at the end of this manual)

Information about software	i
---	---

About this manual

- This manual describes how to operate this Player using a remote control except when it is not available. Some of these operations are also available using the front panel buttons.
- Notes contain important information about safety and operating instructions. Hint(s) indicates a tip for your operation.
- This manual is printed prior to production. Design and specifications are subject to change in part as a result of improvements, etc. In case of differences between the manual and the product, the product has priority.

The icons used in this manual

Icons are used to indicate available buttons/functions for a particular format. For details on playable discs and formats, see page 3.

BD	: BD-Video
DVD	: DVD-Video, DVD-VR, DVD+VR
CD	: Audio CD
VIDEO	: Video files
MUSIC	: Audio files
PHOTO	: Photo files

2

3

4

5

English

What you can do with this Player

Easy setting for language, resolution, screen aspect ratio → p. 12

You can perform language and TV settings.

Play back commercially-released Blu-ray Disc™/Blu-ray 3D™/DVD/CD discs* → p. 17

In addition to Blu-ray Discs, this Player also supports playback of a variety of other discs.

Play back BONUSVIEW™, BD-Live™, etc.* → p. 20

You can enjoy additional movies on the latest Blu-ray Discs.

Play back Video, Music, Photo files on a disc/USB memory device* → p. 13

Files recorded on discs/USB memory devices can be played back with this Player.

Play back Video, Music, Photo files on a Home Network Server* ** → p. 15

PC contents can be played back with TV or AV receiver by connecting this Player to a network server.

Operation with the remote control of TV, AV receiver, etc. → p. 24

Connecting devices with an HDMI cable, you can control devices with a single remote control using the HDMI Control function.

Streaming Playback contents on the Network Services** → p. 16

You can instantly enjoy videos over the internet with this Player.

* For details on playable discs and formats, see page 3.

** Network setting is needed to use this function.

Supplied parts

Make sure the following accessories are provided with the product.

Remote control



**Batteries (x2)
(AAA, R03, UM-4)**

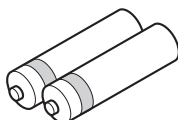

Types of discs/files that can be used with this Player

- 12 cm (5") and 8 cm (3") discs can be played back in this Player. Do not use an 8 cm (3") to 12 cm (5") adapter.
- Use discs that conform to compatible standards as indicated by the presence of official logos on the disc label. Playback of discs not complying with these standards is not guaranteed. In addition, the image quality or sound quality is not guaranteed even if the discs can be played back.

Media Type	Recording Format
BD-ROM/BD-R/ BD-RE	BD-Video/Data files
DVD-ROM	DVD-Video
DVD-R/DVD-R DL/DVD-RW	DVD-Video/DVD-VR/AVCHD/Data files
DVD+R/DVD+R DL/DVD+RW	DVD-Video/DVD+VR/AVCHD/Data files
CD-ROM	CDDA/HDCD
CD-R/CD-RW	CDDA/Data files
USB*	Data files
DLNA	Data files

* This Player is compatible with a USB memory device formatted with FAT 16/32 and NTFS.



Playable audio file formats MUSIC	Playable video file formats VIDEO	Playable photo file formats PHOTO
MP3 (.mp3) WMA (.wma) AAC (.aac/.m4a) WAV (.wav) FLAC (.flac)	MKV with H.264 (.mkv) MPEG PS (.mpeg/ .mpg) MPEG TS (.ts) MPEG-4 (.mp4) VOB (.vob) AVI (.avi) ASF (.asf) WMV (.wmv)	JPEG (.jpeg/.jpg) GIF (.gif) PNG (.png)

Notes

- Playback of a file listed in the chart above is not guaranteed depending on methods of file creation or codecs used.
- A copyright protected file cannot be played back.
- When using DLNA, a file needs to meet the DLNA sever requirement.

Region management information for Blu-ray Disc/DVD videos

- Blu-ray Disc/DVD video players and discs have region codes, which dictate the regions in which a disc can be played. Verify the region code mark on the rear panel of this Player.
- For a Blu-ray Disc, the disc can be played back on this Player with the same region code mark, or the region code "ABC" mark.
- For a DVD disc, the disc can be played back on this Player with the same region code mark, or the region code "ALL" mark.

Examples of region codes	
BD-Video	DVD-Video
Region code "A" or "ABC" 	Region code "1" or "ALL" 

Notes

- Blu-ray Disc/DVD video operations and functions may be different from the explanations in this manual and some operations may be prohibited due to disc manufacturer's settings.
- If a menu screen or operating instructions are displayed during playback of a disc, follow the operating procedure displayed.
- Playback for some of the discs may not be possible depending on the disc.
- Finalize all recording media that is played back in this Player.
- "Finalize" refers to a recorder processing a recorded disc so that it will play in other players/recorders as well as this Player. Only finalized discs can be played back in this Player. (This Player does not have a function to finalize discs.)
- Playback of all files on the disc, USB memory device and network is not guaranteed.
- A copyright protected file cannot be played back via USB memory device and network.

Audio file requirement

- Sampling frequency: within 32 - 48 kHz (MP3/WMA), LPCM 44.1 kHz/16 bit/Stereo (WAV), 192 kHz/24 bit (FLAC)
- Bitrate: within 8 - 320 kbps (MP3), 32 - 192 kbps (WMA)

WMV file requirement

- WMV9, maximum resolution is 1,920 × 1,080.

■ Loading a disc

- Insert the disc with the label facing up.
- In case of the disc recorded on both sides, face down the side to play back.

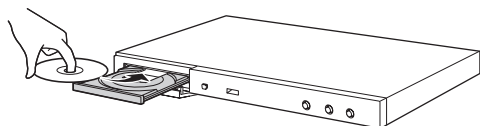

Notes





- Playback may begin automatically, depending on the disc and setting of this Player.
- The menu may be displayed first, depending on the disc.
- The disc load time may vary depending on the disc.

■ Disc precautions

Be careful of scratches and dust

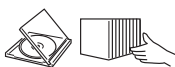
- Blu-ray Disc, DVD and CD discs are sensitive to dust, fingerprints and especially scratches. A scratched disc may not be able to be played back. Handle discs with care and store them in a safe place.

Proper disc storage

Place the disc in the center of the disc case and store the case and disc upright.	
Avoid storing discs in locations subject to direct sunlight, close to heating appliances or in locations of high humidity.	
Do not drop discs or subject them to strong vibrations or impacts.	
Avoid storing discs in locations where there are large amounts of dust or moisture.	

Handling precautions



- If the surface is soiled, wipe gently with a soft, damp (water only) cloth. When wiping discs, always move the cloth from the center hole toward the outer edge.



- Do not use record cleaning sprays, benzene, thinner, static electricity prevention liquids or any other solvent.
- Do not touch the surface.
- Do not stick paper or adhesive labels to the disc.
- If the playing surface of a disc is soiled or scratched, the Player may decide that the disc is incompatible and eject the disc tray, or it may fail to play the disc correctly. Wipe any dirt off the playing surface with a soft cloth.

Cleaning the pick up lens

- Never use commercially available cleaning discs. The use of these discs can damage the lens.
- Request the nearest service center approved by Yamaha to clean the lens.

■ Notice for watching 3D video images

- Some people may experience discomfort (such as eye strain, fatigue, or nausea) while watching 3D video images. We recommend that all viewers take regular breaks while watching 3D video images.
- If you experience any discomfort, stop watching the 3D video images until the discomfort subsides. Consult a doctor if you experience severe discomfort.
- Read the owner's manuals (Blu-ray Disc and TV) and/or the caution messages that appear on the TV carefully.
- The vision of young children (especially those under six years old) is still under development. Consult your doctor (such as a pediatrician or eye doctor) before allowing young children to watch 3D video images.
- Adults should supervise young children to ensure they follow the recommendations described above.

■ Cinavia technology

- Cinavia technology is a part of the content protection system included in your Blu-ray Disc Player.

Note

- The following messages may be displayed and playback stopped or audio outputs temporarily muted by your Blu-ray Disc player if you are playing an unauthorized copy of content that is protected by Cinavia technology.

These messages are displayed in English only.

Playback stopped. The content being played is protected by Cinavia™ and is not authorized for playback on this device.
For more information, see <http://www.cinavia.com>.
Message Code 1.

Audio outputs temporarily muted. Do not adjust the playback volume. The content being played is protected by Cinavia™ and is not authorized for playback on this device.
For more information, see <http://www.cinavia.com>.
Message Code 3.

Cinavia Notice

This product uses Cinavia technology to limit the use of unauthorized copies of some commercially-produced film and videos and their soundtracks. When a prohibited use of an unauthorized copy is detected, a message will be displayed and playback or copying will be interrupted. More information about Cinavia technology is provided at the Cinavia Online Consumer Information Center at <http://www.cinavia.com>. To request additional information about Cinavia by mail, send a postcard with your mailing address to: Cinavia Consumer Information Center, P.O. Box 86851, San Diego, CA, 92138, USA.

■ Front panel

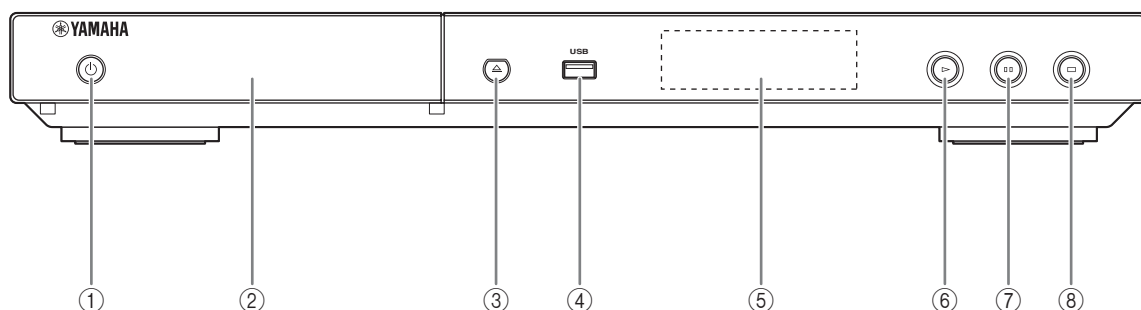

- ① **⏻ (On/Standby)**
Turns this Player on/Sets to standby mode.
Press and hold ⏻ on the front panel for more than 5 seconds, and release to reset this Player (system reset).
- ② **Disc tray door**
Opens/Closes the disc tray.
- ③ **▲ (Eject)**
Opens/Closes the disc tray.
- ④ **USB connector (p. 11)**
- ⑤ **Front panel display**
Displays various information for operational status.
- ⑥ **▶ (Play)**
Starts a playback.
- ⑦ **⏸ (Pause)**
Pauses a playback.
- ⑧ **■ (Stop)**
Stops a playback.

Note

- A factory-fitted protective film covers the front panel of this Player. Remove the protective film from the Player before operating it.

■ Rear panel

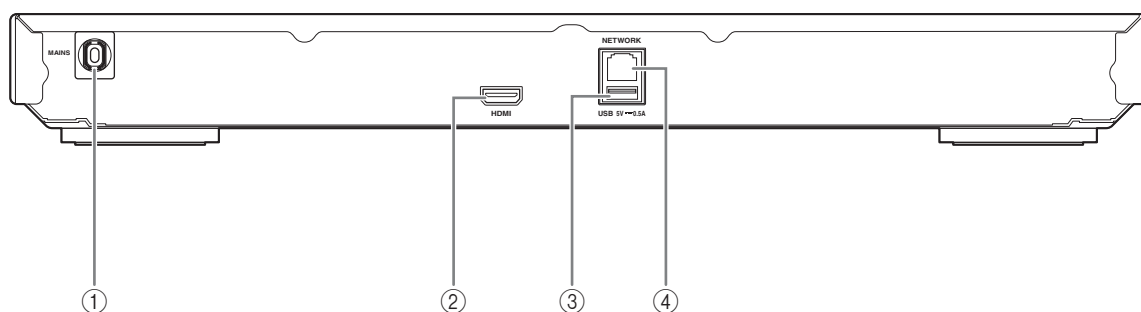

- ① **Power cable**
This Player has a captive power cable. Connect it to an AC outlet after all connections are made (p. 10).

Note

- To prevent risk of electric shock, do not touch the un-insulated parts of any cables while the power cable is connected.





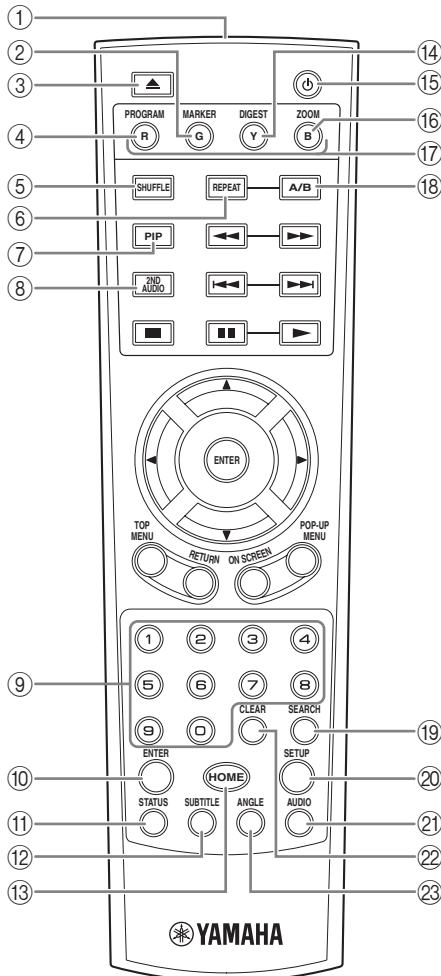

- ② **HDMI terminal (p. 10)**
- ③ **USB connector (p. 11)**
- ④ **NETWORK terminal (p. 11)**

Remote control

Note

-  will appear on the top left corner of the screen when the pressed button is not available.



- ① **Infrared signal transmitter:** Outputs infrared signal. Aim this window to the remote control sensor (p. 9).
- ② **MARKER DVD VIDEO:** Sets Bookmark (p. 19) at a specified point of a movie. After Bookmark is set, to select the set point you want to jump to, press **DIGEST**. You can set up to 12 Bookmarks.
- ③ **▲:** Opens/closes the disc tray.
- ④ **PROGRAM DVD CD:** Sets the order of playback (p. 19). You can set up to 15 tracks (for an audio disc) or titles/chapters (DVD-Video).
- ⑤ **SHUFFLE DVD CD VIDEO MUSIC PHOTO:** Selects shuffle play mode (p. 17).
- ⑥ **REPEAT BD DVD CD VIDEO MUSIC PHOTO:** Changes repeat mode. Repeat mode shown below will change each time you press the button.
 - : Repeats the title being played back.
 - : Repeats the chapter being played back.
 - : Repeats the folder being played back.
 - : Repeats all tracks/files on the disc.
 - : Repeats the track/file being played back.
- ⑦ **PIP BD:** Turns on/off the Picture in Picture (p. 20). PIP Mark () is displayed on the screen when this function is available. You can also select this item from On Screen menu (p. 17).

Note

- PIP Mark is displayed only when the PIP Mark is set to on (p. 25).

- ⑧ **2ND AUDIO BD:** Selects the secondary audio of the Picture in Picture (p. 20) or audio commentaries. The Secondary Audio Mark () is displayed on the screen when this function is available (p. 27). You can also select this item from On Screen menu (p. 17).

Note

- Secondary Audio Mark is displayed only when Secondary Audio Mark is set to on (p. 25).
- ⑨ **Number buttons:** Enters numbers, or during playback, jumps to the track/chapter corresponding to the number you input. These buttons may not be available depending on the disc type and playback condition.
 - ⑩ **ENTER:** Selects the focused menu/item.
 - ⑪ **STATUS:** Displays the playback information (p. 18).
 - ⑫ **SUBTITLE BD DVD VIDEO:** Changes subtitle languages (p. 35) if available. You can also select this item from On Screen menu (p. 17).

- ⑬ **HOME**: Displays the HOME menu screen (p. 13).
- ⑭ **DIGEST PHOTO**: Shows 12 photo thumbnails.
When thumbnails are displayed, you can proceed to the next/previous page with ◀◀/▶▶.
- DVD VIDEO**: Displays Bookmark select bar (p. 19).
- ⑮ **⏻**: Turns this Player on or sets it to standby mode.
- ⑯ **ZOOM DVD VIDEO PHOTO**: Zooms in/out.
The size of the screen will change each time you press the button (zoom in/out: 3 steps each).
- ⑰ **Color buttons BD**: Use these buttons according to on-screen instructions.
- ⑱ **A/B BD DVD CD VIDEO MUSIC**: Plays back a specific part you want to repeat.
- 1 Press **A/B** at the scene where you want to set the start point. "A-" is displayed on the screen.
 - 2 Press **A/B** again at the scene where you want to set the end point. "A-B" is displayed on the screen. Repeat playback starts.
 - 3 To cancel the repeat playback, press **A/B**. "A-B" disappears and the repeat playback is finished.

Note

– This function cannot be performed depending on the specifications of the disc.

- ⑲ **SEARCH BD DVD CD VIDEO MUSIC**:
Jumps to a specified point during playback. For details on this function, refer to "Using Search" (p. 19). You can also select this item from status menu (p. 18).
- ⑳ **SETUP**: Displays SETUP menu screen (p. 21).
- ㉑ **AUDIO BD DVD**: Changes the audio language or format. You can also select this item from On Screen menu (p. 17).
- ㉒ **CLEAR**: Clears entered number/set item.
- ㉓ **ANGLE BD DVD**: Changes the camera angle if video is recorded with multiple angles. The Angle Mark () is displayed on the screen when this function is available. You can also select this item from On Screen menu (p. 17).

Note

– Angle Mark is displayed only when the Angle Mark is set to on (p. 25).

Continued to the next page. ➔

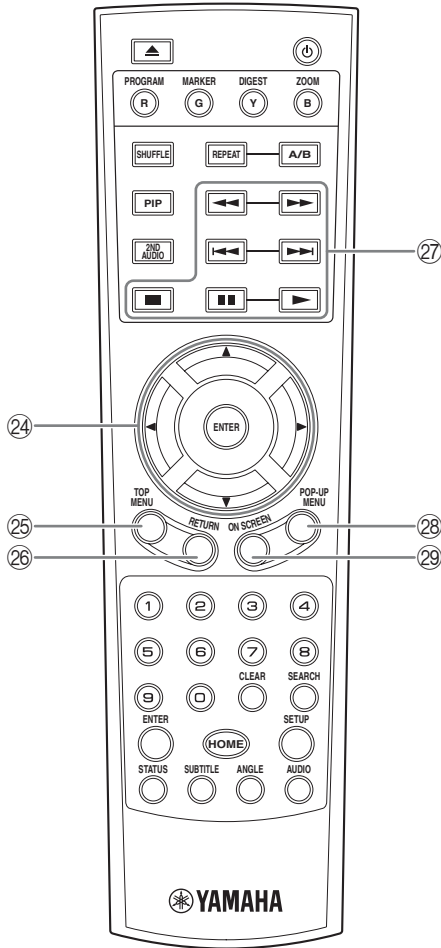

②④ **Cursor buttons (▲/▼/◀/▶)**: Moves the focus in the menu screen.

ENTER: Selects the focused menu/item.

②⑤ **TOP MENU [BD] [DVD]**: Displays the top menu screen if the disc contains a menu. Select the desired item using ▲/▼/◀/▶ and **ENTER**.

Note

– Specific operations may be different depending on the disc. Follow the instructions of each menu screen.

②⑥ **RETURN**: Returns to the previous menu or screen, etc.

②⑦ **Control buttons**

[BD] [DVD] [CD] [VIDEO] [MUSIC] [PHOTO]

■: Stops playback. To stop playback completely, press this button twice.

■: Pauses playback.

▶: Plays back contents.



[BD] [DVD] [CD] [VIDEO] [MUSIC]:

Searches backward/forward. The search speed will change each time you press the button (search backward/forward: 5 steps each). Press ▶ to resume normal playback.

[PHOTO]: Changes the speed of a slide show (slower/faster: 3 steps).

◀◀/▶▶: Skips backward/forward.

Note

– Depending on the disc, this Player resumes playback from the point that where the Player was previously stopped. To play back from the beginning, press ■ twice and then ▶.

②⑧ **POP-UP/MENU [BD] [DVD]**: Displays pop-up menu. The menu contents displayed vary depending on the disc. For details on how to see and operate the pop-up menu, refer to the manual for the disc. The top menu screen may be displayed by pressing **POP-UP/MENU** depending on the DVD.

②⑨ **ON SCREEN**: Displays On Screen menu (p. 17).

Loading the batteries in the remote control

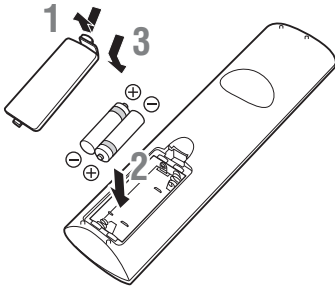

Notes

- Change both batteries when the operation range of the remote control decreases.
- Use AAA, R03, UM-4 batteries.
- Make sure that the polarities are correct. Refer to the illustration inside the battery compartment.
- Remove the batteries if the remote control is not to be used for an extended period of time.
- Do not use old batteries together with new ones.
- Do not use different types of batteries (such as alkaline and manganese batteries) together. Read the packaging carefully as these different types of batteries may have the same shape and color.
- If the batteries have leaked, dispose of them immediately. Avoid touching the leaked material or letting it come into contact with clothing, etc. Clean the battery compartment thoroughly before installing new batteries.
- Do not throw away batteries with general house waste; dispose of them correctly in accordance with your local regulations.
- Keep batteries away from children. If a battery is accidentally swallowed, contact your doctor immediately.
- When not planning to use the remote control for long periods of time, remove the batteries from the remote control.
- Do not charge or disassemble the supplied batteries.

Approximate operating range of remote control

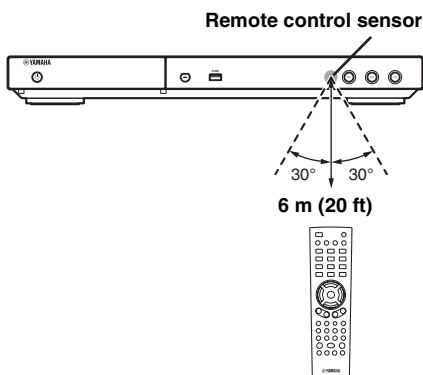

HDMI connection

■ Connecting to the HDMI terminal

- You can enjoy high quality digital picture and sound through the HDMI terminal.
- Firmly connect an HDMI cable (commercially available) to the HDMI terminals.
- See page 28 for information on the audio/video output formats.
- Use HIGH SPEED HDMI cables that have the HDMI logo (as shown on the back cover).

Caution!

Do not connect the power cable of this Player until all connections are completed.

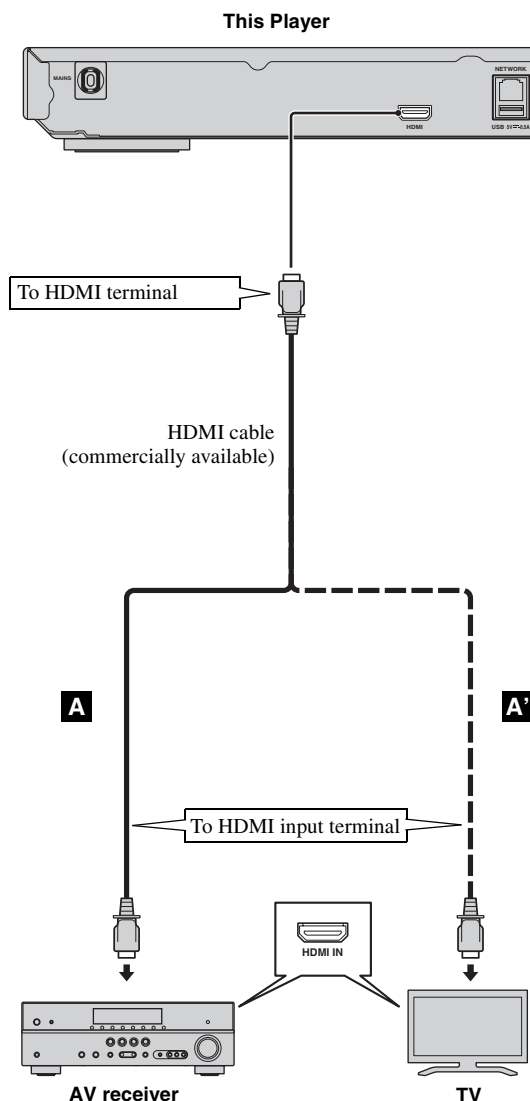

Hints

- When you use the HDMI Control function, refer to the “HDMI Control” (p. 24).
- For information on the output mode of HDMI terminal, refer to the “HDMI” (p. 27).
- When no picture is displayed, refer to “Troubleshooting” (p. 32).

■ Connection for the playback of Blu-ray 3D Discs

To enjoy Blu-ray 3D Discs on this Player, you need the following equipment and connections:

- You need a TV and an AV receiver (if you need) that have 3D functionality.
- All the components must be connected with HDMI cables.
- A Blu-ray Disc should contain 3D images.
- You need to set 3D Output in Display Setting (p. 26) to Auto.

Network and USB connection

■ Connecting to the NETWORK terminal

- PC contents can be played back by connecting this Player to the network.
- You can enjoy a variety of contents with interactive functions by connecting to the internet when playing BD-Live compatible discs. Refer to page 20 regarding further information on BD-Live functions.

Notes

- Firmly connect a network cable (commercially available) to the NETWORK terminal.
- Use only an STP (shielded twisted pair) network cable.
- When using the internet, a broadband internet connection as shown below is required.
- Connect the other connector of the network cable to the hub/broadband router.
- When using a broadband internet connection, a contract with an internet service provider is required. For more details, contact your nearest internet service provider.
- Refer to the operation manual of the equipment you have as the connected equipment and connection method may differ depending on your internet environment.
- Use a network cable/router supporting 10BASE-T/100BASE-TX.

■ Connecting to the USB connector

- You can connect a USB memory device for Local Storage to the USB connector on the rear panel (or front panel) of this Player to save the BD-Live data, or to upgrade the software of this Player.
- Firmly connect a USB memory device (commercially available) to the USB connector.

CAUTION:

- Do not remove the USB memory device or unplug the power cable while the operations for BD-Live (p. 20) or software upgrade are being performed.
- Do not use a USB extension cable when connecting a USB memory device to the USB connector of this Player. Using a USB extension cable may prevent the Player from performing correctly.

Note

- Yamaha cannot guarantee that all brands' USB memory devices will operate with this Player.

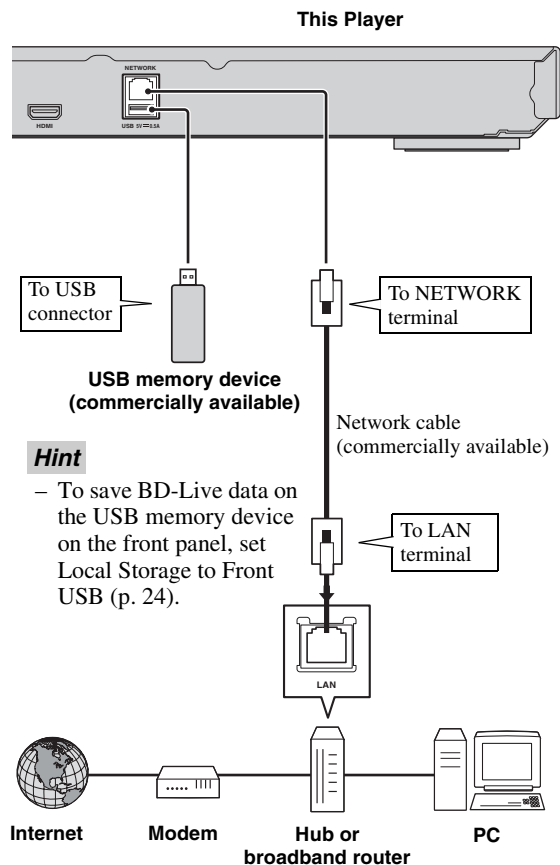

After connecting

- When you set the Network setting manually, refer to "Network" (p. 25).
- To play back the PC contents on your network, refer to "Using network content" (p. 15).

Initial Wizard/Easy Setup

■ Setting with the Initial Wizard/Easy Setup

Initial Wizard/Easy Setup allows you to set language, resolution, and screen aspect ratio easily. Initial Wizard screen is displayed when you turn this Player on for the first time after purchase. Same setting can be performed from SETUP menu → System → Easy Setup.

- 1 When Easy Setup screen is displayed, press **ENTER** to start Easy Setup.

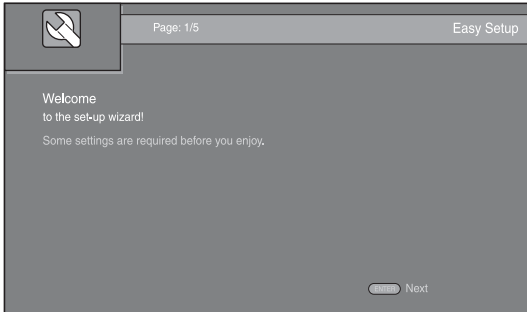

- 2 Set the language, resolution, and screen aspect ratio by following the on-screen messages.

Notes

- When no picture is displayed after Initial Wizard/Easy Setup is completed, refer to “Troubleshooting” (p. 32).
- A warning message concerning 3D video playback appears when this Player is turned on. Press **ENTER** to dismiss the message or **CLEAR** to disable it (p. 24).

HOME/MEDIA menu

HOME and MEDIA menus allow you to browse and play multi-media files on data discs, USB memory devices and your network.

Note

- For details on playable discs and formats, see page 3.

■ Playing back photo/music/video

Basic operation

◀/▶/▲/▼: Moves the focus.

◀: Returns to the parent folder.

HOME: Moves to/exits HOME menu screen.

ENTER: Confirms the folder/file.

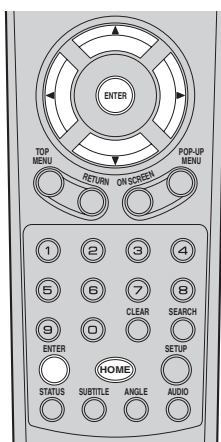

Icons on the top of MEDIA menu

📀: Plays back the disc on the tray, or displays contents in the data disc.

🔑: Displays contents in the USB memory device connected to the USB connector.

🌐: Searches for a DLNA (p. 15) server on the network.

🖥️: Displays contents on the connected DLNA server.

Common operations for playing back files in a selected folder

Example: Selecting a movie file on a USB memory device

Note

- Stop the playback of the video before you move to MEDIA menu screen.

- 1 Press **HOME** to move to HOME menu screen.

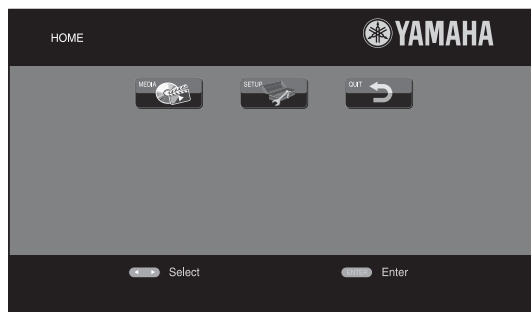

Hint

- The HOME menu screen may differ depending on the model.

- 2 Press ◀/▶/▲/▼ to select MEDIA, then press **ENTER**. MEDIA screen appears.

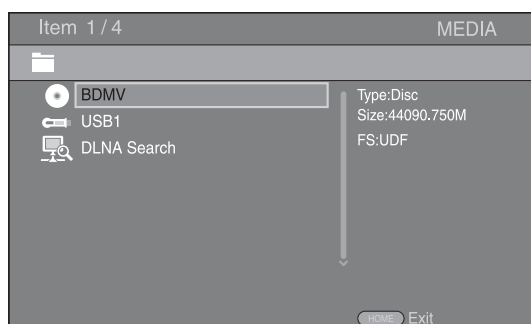

- 3 Select the item which contains the file you want to play back, then press **ENTER**.

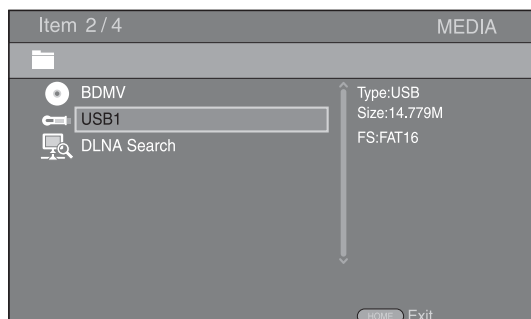

- 4 Select the Photo, Music, Video or AVCHD folder you want to play back, then press **ENTER**.

To return to the parent folder, press **◀** or select **⬆**.

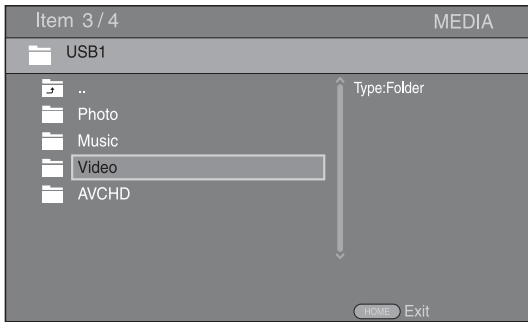

Note

- Note that the only the file type selected on this step will be displayed in the following step. For example, if you selected Photo folder in this step, only photo files are displayed after this step. When you want to play back other than photo, return to this step and select file type again.

- 5 Select the folder(s) containing the file you want to play back.

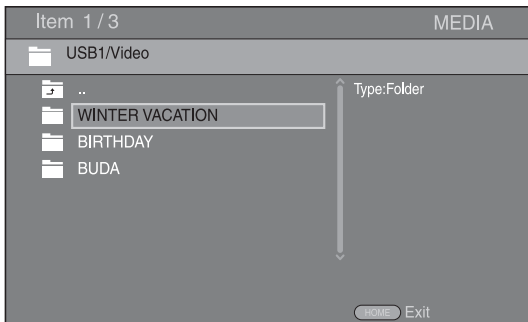

- 6 Select the file you want to play back, then press **ENTER**.

When a video file is selected, playback starts.

When a music file is selected, status screen is displayed and playback starts.

When a photo file is selected, slide show starts.

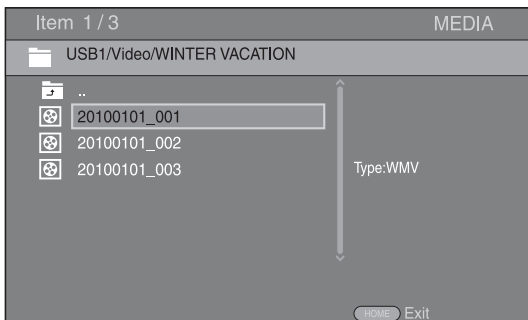

Hint

- To enjoy slide show with music, press **HOME** to return to the HOME menu screen while music is played back, and select photo file.

Note

- The displayed file may not be played back depending on the content.

Operations for viewing photos

While viewing photos, the buttons on the remote control work as shown below.

- : Stops slide show and returns to the file browser.
- : Pauses a slide show.
- ▶: Plays a slide show.
- ▶▶: Moves to a next photo.
- ◀◀: Moves to a previous photo.
- ▶▶▶: Makes a slide show faster in 3 steps.
- ◀◀◀: Makes a slide show slower in 3 steps.
- ▲: Inverts a photo.
- ▼: Reflects a photo.
- ◀: Rotates a photo counterclockwise.
- ▶: Rotates a photo clockwise.
- ZOOM:** Zooms in/out a photo (zoom in/out: 3 steps each).
 - ▲/▼/◀/▶: Pans in zoom mode when a photo is larger than the screen.
- DIGEST:** Switches to thumbnail mode (p. 7). When thumbnails are displayed, you can proceed to the next/previous page with ◀◀◀/▶▶▶.

■ Using network content

This Player is DLNA certified (p. 34). You can manage photo, music and video contents stored on DLNA servers on your home network.

Playing back shared contents

- 1 To play back files on your PC, install a DLNA server software, such as Windows Media Player 12, and share files you want to play back.
- 2 Turn on the PC with DLNA server software installed or the DLNA device connected to your home network.
- 3 Press **HOME** to display HOME menu screen. Then select **MEDIA** to move to MEDIA menu. The DLNA servers connected to the network are listed on the screen.

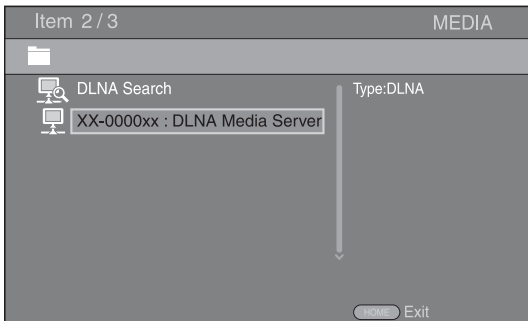

Notes

- If your DLNA server is not listed, select DLNA Search to find it.
 - Depending on the DLNA server, this Player may need to be permitted from the server.
 - To play the file on the DLNA server, this Player and the server must be connected to the same access point.
 - The file requirements may not always be compatible. There may be some restrictions depending on file features and DLNA sever capability.
- 4 Select the file you want to play back.

Notes

- The playback and operating quality may be affected by your home network condition.
- The files from removable media such as USB memory devices or DVD-drive on your media server, may not be shared properly.

Using network services

You can instantly watch the videos that the following network services provide.

- YouTube

Notes

- Access to content provided by third parties requires a high speed internet connection and may also require account registration and a paid subscription.
- Third party content services may be changed, suspended, interrupted, or discontinued at any time without notice, and Yamaha disclaims any liability in connection with such occurrences.
- Some content may only be available for specific countries and may be presented in specific languages.
- Yamaha does not represent or warrant that content services will continue to be provided or available for a particular period of time, and any such warranty, express or implied, is disclaimed.

Playing videos from YouTube™

You can watch movies from YouTube over the internet using this Player.

The services may be changed without notice.

- 1 Press **HOME** to display HOME menu screen.

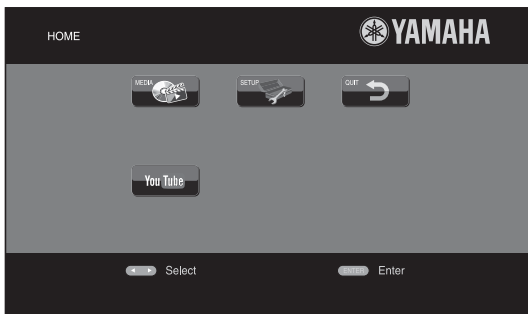

Hint

- The HOME menu screen may differ depending on the model.

- 2 Press **◀/▶/▲/▼** to select YouTube, then press **ENTER**.

Hint

- To return to the HOME menu screen, press **RETURN**.

Advanced playback operation

This chapter explains playback of commercially available Blu-ray Discs, DVDs, CDs, and recorded DVD-RW/R discs.

Note

- For the basic playback operation, see page 6.

■ On Screen menu

To display On Screen menu, press **ON SCREEN**. After that, press **▲/▼/◀/▶** to select an item, then press **ENTER** to operate the desired function.

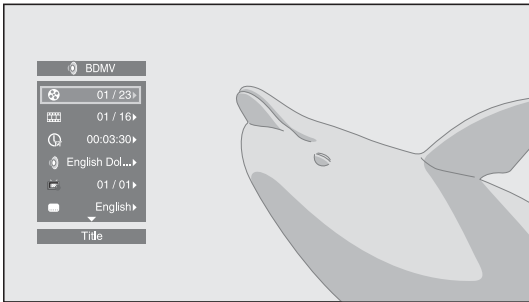

On Screen menu contains following items.

Title **BD** **DVD** **VIDEO** : Shows the title number being played back. You can skip to the desired title by selecting it from this item.

Chapter **BD** **DVD** **VIDEO** : Shows the chapter number being played back. You can skip to the desired chapter by selecting it from this item.

Track/File **CD** **VIDEO** **MUSIC** **PHOTO** : Shows track/file number being played back. You can skip to the desired track/file by selecting it from this item.

Time **BD** **DVD** **CD** **VIDEO** **MUSIC** : Shows the playback time. Select display type from the following:

- Elapsed playback time of the title, chapter, disc, track or file
- Remaining playback time of the title, chapter, disc, track or file

Mode/Play Mode

DVD **CD** **VIDEO** **MUSIC** **PHOTO** : Shows current playback mode. You can select playback mode from the following:

- CD**
 - Normal: Normal playback.
 - Shuffle: Random playback without repetition.
 - Random: Random playback with repetition.

DVD

- Normal
- Shuffle CH (chapter)
- Shuffle TT (title)
- Shuffle All
- Random CH (chapter)
- Random TT (title)
- Random All

VIDEO MUSIC PHOTO

- Normal
- Shuffle F (folder)
- Random F (folder)

Audio **BD** **DVD** **VIDEO** : Shows audio language/signal of a Blu-ray Disc/DVD currently selected. You can select the desired type of audio.

Angle **BD** **DVD** : Shows the currently-selected angle number. If the video is recorded with multiple angles, you can change the angle.

Subtitle **BD** **DVD** **VIDEO** : Shows the currently-selected subtitle language when the subtitle is provided.

Subtitle Style **BD** : Shows the currently-selected subtitle style. This function is available only for Video-file external subtitle. You can select the desired text style of subtitle.

Bitrate **BD** **DVD** **CD** **VIDEO** **MUSIC** : Shows bitrate of the audio/video signal.

Second Video **BD** : Turns the PIP on/off (p. 6).

Second Audio **BD** : Turns the secondary audio on/off (p. 6).

Ins Search

BD **DVD** **CD** **VIDEO** **MUSIC** : Skips 30 seconds.

Ins Replay

BD **DVD** **CD** **VIDEO** **MUSIC** : Replays the content from 10 seconds before.

Slide Show PHOTO :

Shows slide show speed. You can select the slide show speed from Slow/Medium/Fast.

Transition **PHOTO** : Shows how photo appears on the screen. You can select the transition type.

■ Status menu

This shows various settings, such as subtitles, angle settings and the title/chapter/track number currently played back. To display status menu, press **STATUS**. Status menu contains following menus.

BD DVD VIDEO

Example: Icons when playing a Blu-ray Disc

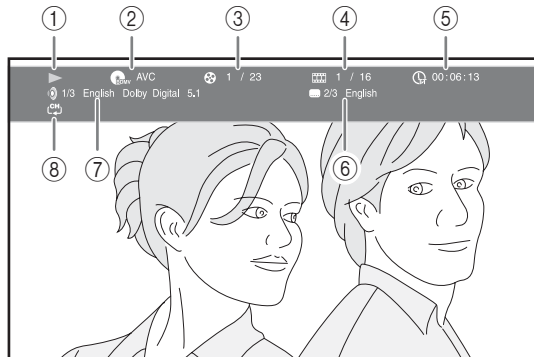

- ① **(Playback status)**
- ② **(Disc type/video file icon)**
- ③ **(Title number being played):** You can jump to specified title with **SEARCH** button (p. 7).
- ④ **(Chapter number being played):** You can jump to specified chapter with **SEARCH** button (p. 7).
- ⑤ **(Elapsed playback time):** You can jump to specified point with **SEARCH** button (p. 7).
- ⑥ **(Subtitle currently selected):** You can change the subtitle language with **SUBTITLE** button.
- ⑦ **(Audio currently selected):** You can change the audio language or format with **AUDIO** button.
- ⑧ **(Repeat mode):** Shows current repeat mode (p. 6).

CD MUSIC

Example: Icons when playing a music file

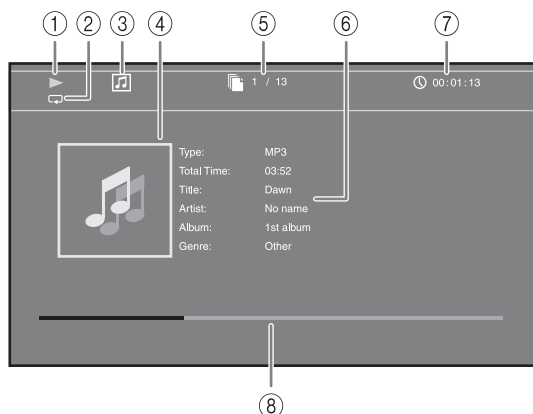

- ① **(Playback status)**
- ② **(Repeat mode):** Shows current repeat mode (p. 6).
- ③ **(Disc type/music file icon)**
- ④ **(Artwork) MUSIC:** Displays artwork if the file contains it.
- ⑤ **(Track/file number being played):** You can jump to specified track with **SEARCH** button (p. 7).
- ⑥ **(Information) MUSIC:** Displays music information if the file contains them.
- ⑦ **(Elapsed playback time):** You can jump to specified point with **SEARCH** button (p. 7).
- ⑧ **(Progress bar) MUSIC:** Shows progress status of current song.

PHOTO



- ① **(Playback status)**
- ② **(Photo file icon)**
- ③ **(File number being displayed)**
- ④ **(Repeat mode):** Shows current repeat mode (p. 6).
- ⑤ **(Slide show speed)**

■ Using Bookmark DVD VIDEO

This allows you to set Bookmark at the specified point of the video. After Bookmark is set, you can move to the point you set using this function. You can set up to 12 Bookmarks.

- 1 Press **MARKER** during playing back the movie to set Bookmark. Bookmark number, and the status are displayed.

Bookmark: 1/12 Title: 1 Chapter: 1 Time: 00:01:26

- 2 After Bookmark is set, press **DIGEST** to display Bookmark select bar.

Title:01 Chapter:01 Time:00:01:26 Bookmark
 01 02 03 04 05 06 07 08 09 10 11 12 Clear

- 3 Press **◀/▶** to select the Bookmark you want to play back, then press **ENTER**. Press **CLEAR** to delete the selected Bookmark.

Note

- When playback is finished (e.g., ejecting the disc, pressing **■** twice), Bookmarks are automatically deleted.

■ Program play DVD CD

This allows you to program playback order of audio disc tracks or DVD chapters.

Press **PROGRAM** during playback to display the PROGRAM window to program playback order. You can program up to 15 tracks/chapters.

Example: Programming the playback order of CD tracks

- 1 Press **PROGRAM** during playback.

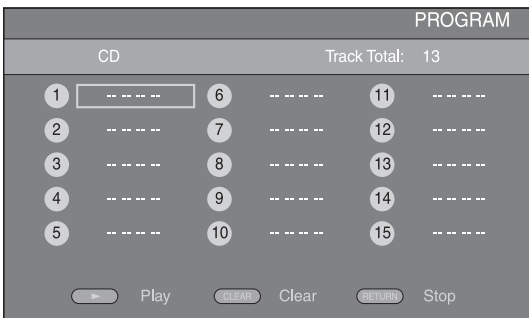

- 2 Press **ENTER** to program playback order. For audio disc, press **▲/▼** to select a desired track then press **ENTER**. For DVD-Video disc, select a desired title (shown as TT) and chapter (shown as CH) instead of a track. To clear a set track, select the track you want to clear, then press **CLEAR**. Press **RETURN** to cancel the Program play.

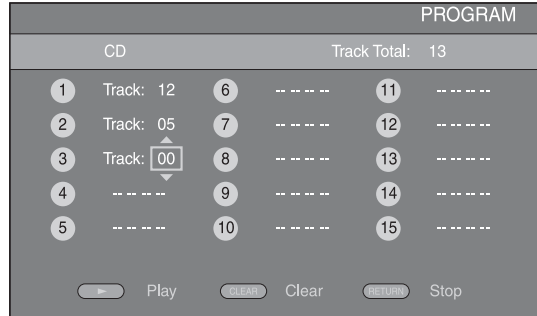

- 3 After programming is finished, press **▶** to set and start program playback.
- 4 To cancel program play, stop playback completely by pressing **■** twice.





■ Using Search

BD DVD CD VIDEO MUSIC PHOTO



This allows you to jump to the specified point during playback.

- 1 Press **SEARCH** during playback. Status bar appears.
- 2 Press **▲/▼/◀/▶** to select one of the item below, then press **ENTER**.

BD **DVD** :

- Title number (shown as )
- Chapter number (shown as )
- Elapsed title time (shown as )
- Elapsed chapter time (shown as )

CD :

- Track number (shown as )
- Elapsed track time (shown as )
- Elapsed disc time (shown as )

VIDEO **MUSIC** :



- File number (shown as )
- Elapsed file time (shown as )

PHOTO :

- File number (shown as )

- 3 Press **▲/▼** or number buttons to set/adjust the value of the focused item, and press **ENTER** to jump to the specified point.
- 4 To close the status bar, press **STATUS**.

■ Enjoying BONUSVIEW™ and BD-Live™

This Player supports BONUSVIEW (p. 34) (BD-ROM Profile 1 Version 1.1) and BD-Live (p. 34) (BD-ROM Profile 2) playback functions.



Note

- Functions and playback method vary depending on the disc. See the guidance on the disc or the supplied user's manual.

■ Using Picture in Picture function (secondary audio/video playback)

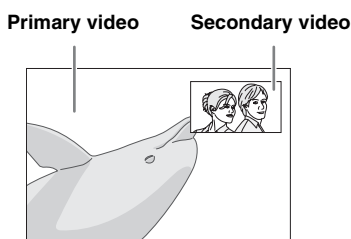
BD-Video that includes secondary audio and video compatible with Picture in Picture can be played back with secondary audio and video simultaneously as a small video in the corner.



While PIP Mark () or Secondary Audio Mark () is displayed, press PIP to turn the Picture in Picture function on/off.

Notes

- To listen to secondary audio, make sure that the Audio Output setting (HDMI) is set to PCM or Reencode (p. 27).
- Depending on the disc, to listen to secondary audio, you may need to set secondary audio to on from the top menu of the disc (p. 8).
- The secondary audio and video for Picture in Picture may automatically play back and be removed depending on the content. Also, playable areas may be restricted.

■ Using the feature of BD-Live™

1. Set the Network setting (p. 25).

2. Connect the USB memory device to this Player (p. 11).

BD-Live data is saved in a USB memory device connected to this Player. To enjoy these functions, connect a USB memory device supporting USB 2.0 High Speed (480 Mbit/s) to the USB connector that you select on Local Storage (p. 24). The default setting is the USB connector on the rear panel.

- BUDA folder is created automatically in the USB memory device when necessary.
- If there is insufficient storage space, the data will not be copied/downloaded. Delete unneeded data or use a new USB memory device.
- Some time may be required for the data to load (read/write).

Notes

- Yamaha cannot guarantee that all brands' USB memory devices will operate with this Player.
- Do not use a USB extension cable when connecting a USB memory device to the USB connector of the Player. Using a USB extension cable may prevent the Player from performing correctly.

3. Play back the disc.

4. Run BD-Live according to the instructions on the disc.



Notes

- Regarding playback method of BD-Live contents, etc., perform the operations in accordance with the instructions in the Blu-ray Disc manual.
- To enjoy BD-Live functions, perform the network connection (p. 11) and Network settings (p. 25).
- Refer to "BD-Live Connection" (p. 25) regarding the setup to restrict access to BD-Live contents.
- The time required to download the provided programs into the USB memory device connected to this Player varies depending on the internet connection speeds and the data volume of the programs.
- BD-Live programs provided through the internet may not be able to display the connection depending on the status (upgrading) of the provider. In such cases, take out the disc and try again.
- If the BD-Live screen does not appear for a while after you select the BD-Live function in the Blu-ray Disc menu, the USB memory device may not have enough free space. In such cases, eject the disc from the Player, and then erase the data in the USB memory device using the "Format" menu in the "Local Storage" (p. 24).

SETUP menu

The SETUP menu enables various audio/visual settings and adjustments for functions using the remote control unit.

Menu/Submenu	Item	Function	Page
 General Setting	System		
	Screen Saver	Sets screen saver on/off.	24
	Disc Auto Playback	Sets this Player to start disc playback automatically.	24
	HDMI Control	Sets this Player to receive control signal from the remote control of your TV/AV receiver.	24
	Load Default	Resets all settings to the default setting except Security setting.	24
	Upgrade	Performs upgrade of this Player.	24
	Easy Setup	Sets language, resolution, screen aspect ratio.	24
	Local Storage	Displays status of Local Storage (p. 24), formats Local Storage and selects the front/rear USB connector for Local Storage.	24
	3D Playback Message	Displays a warning message concerning 3D video playback when this Player is turned on.	24
	Language		
	OSD	Selects the language for On Screen Display.	24
	Menu	Prioritizes the language for disc menu.	24
	Audio	Prioritizes the language for audio.	24
	Subtitle	Prioritizes the language for subtitle.	24
	Playback		
	Angle Mark	Sets to display the Angle Mark when Blu-ray Disc/DVD with multiple angles is played back.	25
	PIP Mark	Sets to display the PIP Mark when Blu-ray Disc/DVD with Picture in Picture is played back.	25
	Secondary Audio Mark	Sets to display the Secondary Audio Mark when Blu-ray Disc/DVD with secondary audio is played back.	25
	Last Memory	Sets this Player to remember the last playback position of a disc when it is set to standby mode or the disc tray is opened.	25
	Security		
	Change Password	Changes password for Parental Control and Country Code.	25
	Parental Control	Sets the Parental Control depending on the disc content.	25
	Country Code	Sets your Country Code.	25
	Network		
	Internet Connection	Sets the internet connection to Enable/Disable.	25
	Information	Displays network information screen.	25
	Connection Test	Performs the network connection test.	25
	IP Setting	Sets the IP setting to Auto/Manual.	25
	BD-Live Connection	Sets the BD-Live connection to Permitted/Partial Permitted/Prohibited.	25
	DLNA	Sets the DLNA to Enable/Disable.	25
Proxy Setting	Sets the proxy setting.	25	

Menu/Submenu	Item	Function	Page		
 Display Setting	TV	3D Output	Selects 3D or 2D videos.	26	
		TV Screen	Sets the screen aspect ratio of the connected TV, and adjust the video output.	26	
		Video Out Select	Selects the resolution of video output.	26	
		TV System	Selects the TV System from NTSC/PAL/Multi.	26	
		Color Space	Selects Color Space from YCbCr 4:4:4/YCbCr 4:2:2/Full RGB/RGB.	26	
		HDMI Deep Color	Selects HDMI Deep Color from 30 bits/36 bits/48 bits/Off.	26	
		HDMI 1080p 24Hz	Sets HDMI 1080p 24Hz to auto/off.	27	
		Lip Sync	Adjusts the lag between video and audio, such as when the mouth movement is out of sync with the voice.	27	
	Video Process	Video Mode	Adjusts the visual image.	27	
		Color Adjust	Adjusts Brightness/Saturation/Hue for each color.	27	
		Noise Reduction	Sets the level of Noise Reduction.	27	
		De-interlacing Mode	Sets how to detect the video signal.	27	
	 Audio Setting	Audio Output	HDMI	Selects the output mode of HDMI terminal from Bitstream/PCM/Reencode/Off.	27
			DRC	Sets the DRC (Dynamic Range Compression).	27
 System Information		Displays software version and MAC address (p. 35).	27		

■ Example of SETUP menu operation

You need to call up the SETUP menu screen to perform settings for this Player. The following is the explanation for basic operations of the SETUP menu.

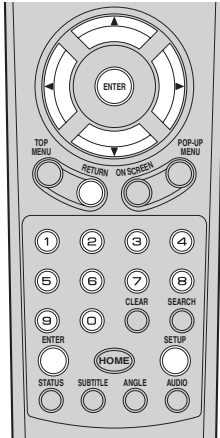

Example: Setting Parental Control

Note

- Some items cannot be set during playback. In this case, press **■** twice to stop playback completely before setting.

1. Display the SETUP menu screen.

Press **SETUP** to display the SETUP menu screen. Press **◀/▶** to select General Setting, then press **ENTER** or **▼**.

2. Select a Submenu.

Press **▲/▼** to select Security, then press **ENTER** or cursor **▶**.

3. Select a menu item.

Press **▲/▼** to select Parental Control, then press **ENTER** or cursor **▶**.

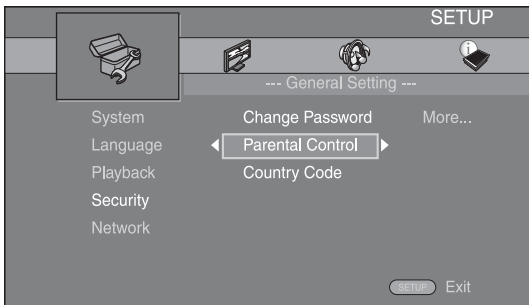

4. Enter password.

- Enter your password with number buttons.
- The default password is 0000.
 - You cannot move to the next setting screen until you have input the correct password.
 - To change the password, refer to “Change Password” (p. 25).

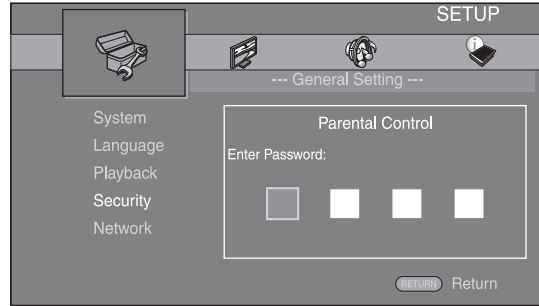

5. Select a next item.

Press **▲/▼** to select the Parental Control Level for Blu-ray Disc/DVD, then press **ENTER**.

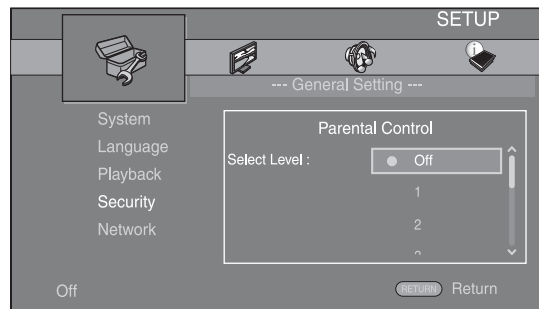

6. Exit the menu screen.

Press **◀** to return to the previous menu.

■ General Setting

The default settings are marked with “*”.

System

Screen Saver

You can set the screen saver to on/off.

When set to on, this Player will switch to screen saver mode if there is no operation for 3 minutes. After that, this Player will turn to standby mode when there is no operation for 27 minutes.

On*, Off

Disc Auto Playback

You can set Disc Auto Playback to on/off. When set to on, a disc will play back automatically after loading.

On*, Off

HDMI Control

You can set the Player to receive control signal from a TV/AV receiver compatible with the HDMI Control function via an HDMI cable (p. 10).

On, Off*

Using HDMI Control function

Using the HDMI Control function, you can interactively operate this Player with your TV (HDMI Control function supported).

When you connect this Player to the TV compatible with the HDMI Control function using an HDMI cable and set HDMI Control in the SETUP menu to on (p. 24), you can perform the function listed below.

- Automatic input select function
When you start playback of this Player, the input selector of the TV (and an AV receiver if this Player is connected to the TV via the AV receiver) is switched to this Player automatically. TV Power is turned on automatically depending on the TV.
- Automatic power off function
When you turn off the TV while this Player is in stop mode and the SETUP menu screen is not displayed, the power of this Player is also turned off automatically.

Notes

- HDMI Control function may not work properly depending on the TV.
- Functions other than ones shown above may work depending on the TV or AV receiver.
- In order to make the HDMI Control function available, set up settings for the HDMI Control function on ALL components (this Player, TV, and AV receiver). Certain operation may also be required.
- Each function may be set independently to activate/deactivate depending on the TV.
- Refer to the operation manuals supplied with the TV and/or AV receiver for details regarding setup.
- When set to on, power consumption during standby mode increases due to HDMI Control function.

Load Default

You can reset all settings of this Player to default setting except Security setting (p. 25). For details on default settings, see pages 21–27.

Upgrade

You can upgrade the software manually from USB Storage or Network. For details on software upgrade, refer to “Software upgrade” (p. 30).

Easy Setup

You can perform Easy Setup (p. 12).

Local Storage

You can display Local Storage information, format Local Storage, and select Front USB/Rear USB to save the BD-Live data.

To format (empty) the “BUDA” folder in the USB memory device, select Information and press **ENTER** when “Format” is focused on the screen.

Front USB, Rear USB*

Hint

- Local Storage is used as an auxiliary memory when Blu-ray Disc is played back.

3D Playback Message

You can turn on or off a warning message concerning 3D video playback that appears on the TV when this Player is turned on.

On*, Off

Language

OSD

You can select the language for On Screen Display which is the messages or menu displayed on the screen such as SETUP menu.

English, Français, Español, Deutsch, Italiano, Svenska, Nederlandse, Русский, 中文

Menu

You can prioritize the language for disc menu.

English, Français, 中文, Español, Deutsch, Italiano, Nederlandse, Portuguese, Danish, Svenska, Finnish, Norwegian, Русский, Korean, Japanese, More

Audio

You can prioritize the audio language for Blu-ray Disc/DVD playback. For details on setting items, see “Menu” (p. 24).

Subtitle

You can prioritize the language for Subtitle.

English, Français, 中文, Español, Deutsch, Italiano, Nederlandse, Portuguese, Danish, Svenska, Finnish, Norwegian, Русский, Korean, Japanese, More, Off

(The default settings in [Language] differ depending on your model.)

Playback

Angle Mark

You can set to display the Angle Mark () when Blu-ray Disc/DVD with multiple angles is played back.

On*, Off

PIP Mark

You can set to display the PIP Mark () when Blu-ray Disc with picture in picture (p. 20) is played back.

On*, Off

Secondary Audio Mark

You can set to display the Secondary Audio Mark () when Blu-ray Disc with secondary audio is played back.

On*, Off

Last Memory

You can set whether this Player remembers the last playback position of a disc when it is set to standby mode or the disc tray is opened.

On*, Off

Note

- Some discs are not compatible with this function.

Security

Change Password

You can set the password for changing the Parental Control Level and Country Code. Refer to “Parental Control” (p. 25) and “Country Code” (p. 25).

Notes

- The default password is 0000.
- If you forget the password, refer to “Troubleshooting” (p. 31) and set all the Security settings to their default settings.

Parental Control

In some Blu-ray Discs/DVDs, a control level for disc viewing is set depending on the age of the viewer. You can set the Parental Control shown on the screen depending on the disc content.

The password (see “Change Password” on p. 25) needs to be entered before the Parental Control Levels is set.

After you set the Parental Control, when you play back a disc with level higher than current Parental Control Level, or you want to change the Parental Control Level, a dialog box will pop up to ask you to enter the password.

Off*, 1–8

Country Code

You can set the Country Code you live in. The password (see “Change Password” on p. 25) needs to be entered before the Country Code is set. This setting may be used for rating of Parental Control and disc playback.

Network

Internet Connection

Set this item to Enable when you use BD-Live (p. 20), DLNA (p. 15), software upgrade from the network (p. 30), and the other network functions.

Enable*, Disable

Information

You can display network information screen. On this screen, you can view the information of Interface (Ethernet), Address Type, IP Address, Subnet Mask, Default Gateway, and DNS.

Connection Test



You can perform an internet connection test. If the test is failed, please check “IP Setting” (p. 25) and perform the test again.

IP Setting

You can configure the network settings.

- Auto*** Select to automatically configure the network settings of this Player with the DHCP server.
- Manual** Select to configure the network settings (IP Address, Subnet Mask, Default Gateway, and DNS) manually.

Hints

- **Numeric keys** Enters characters.
-   Moves the highlight.
- **CLEAR** Deletes a character.
- **ENTER** Saves the settings and exits from the menu.

BD-Live Connection

You can set access restriction to BD-Live contents.

- Permitted** Allows all BD-Live discs to connect the network.
- Partial Permitted*** Allows only discs with owner certification.
- Prohibited** Prohibits all BD-Live discs to connect the network.

DLNA

You can set the DLNA (p. 34) to Enable/Disable. When you do not use the DLNA function, set to Disable.

Enable*, Disable

Proxy Setting

You can set Proxy Setting. Set to Disable for normal use. Set to Enable to set the proxy setting.

- Enable** Enables proxy host and proxy port setting.
- Disable*** Sets proxy server to disable. Select this item when proxy server is not used.
- Proxy Host** Sets proxy host.
- Proxy Port** Sets proxy port.

■ Display Setting

The default settings are marked with “*”.

TV

3D Output

You can select 3D or 2D video output from this Player.

- Auto*** This Player automatically selects 3D or 2D videos.
- Off** This Player always selects 2D videos.

Note

- Even if you set “3D Output” to “Auto” and play back a Blu-ray 3D Disc, this Player selects 2D images depending on the connection and the setting of TV, etc (p. 10).



TV Screen

You can set the screen aspect ratio of the connected TV, and adjust the video output.

If you switch your TV (i.e. because you have bought a new one) and the screen aspect ratio of the connected TV changes, you will have to change the TV Screen setting.

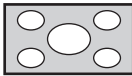
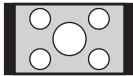
- 16:9 Full** Select this when this Player is connected to a TV with a 16:9 screen. When a 4:3 aspect ratio video is played back, the video is displayed as shown below.
- 16:9 Normal*** Select this when this Player is connected to a TV with a 16:9 screen. When a 4:3 aspect ratio video is played back, the video is displayed as shown below.
- 4:3 Pan Scan** Select this when this Player is connected to a TV with a 4:3 screen. When a 16:9 aspect ratio video is played back, the video is displayed as shown below.
- 4:3 Letter Box** Select this when this Player is connected to a TV with a 4:3 screen. When a 16:9 aspect ratio video is played back, the video is displayed as shown below.

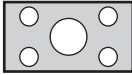
Original image size	On 16:9 (wide screen) TV	
	16:9 Full	16:9 Normal
 4:3		

Original image size	On 4:3 TV	
	4:3 Pan Scan	4:3 Letter Box
 16:9		

Video Out Select

You can select the video output resolution from Auto, 480i/576i, 480p/576p, 720p, 1080i, and 1080p.

When set to Auto, resolution is set to the maximum resolution according to the connected TV.

For more details on output formats, refer to “About the video output formats” (p. 29).

Auto*, 480i/576i, 480p/576p, 720p, 1080i, 1080p

Note

- To output HD audio (Dolby TrueHD or DTS-HD Master Audio) from HDMI terminal, set Video Out Select to Auto or more than 720p.

TV System

You can select TV System from PAL, NTSC and Multi. Set the same TV System as your TV set. For more details on output formats, refer to “About the video output formats” (p. 29).

NTSC, PAL, Multi

(The default setting differs depending on your model.)

Color Space

You can select the Color Space (p. 34) output from HDMI. This function is available when this Player is connected with an HDMI cable.

YCbCr 4:4:4* Sets Color Space to YCbCr 4:4:4.

YCbCr 4:2:2 Sets Color Space to YCbCr 4:2:2.

Full RGB When RGB is set and white and black on the screen are too faint, select this item. This setting is effective when a connected component supports RGB 0–255 range.

RGB Outputs video signal at normal signal range.

Note

- This function is only available on TVs that support this function.

HDMI Deep Color

When your TV and/or AV receiver is compatible with Deep Color (p. 34), set this item according to your TV/AV receiver. This function is available when this Player is connected with an HDMI cable.

30 bits, 36 bits, 48 bits, Off*

HDMI 1080p 24Hz

This outputs the BD-Video encoded in 24Hz frame rate in HDMI 1080p 24Hz. Smoother video playback may be available with this function. This function is available when your TV/AV receiver support this function, and this Player is connected with an HDMI cable. For more details on output formats, refer to “About the video output formats” (p. 29).

Auto*, Off

Note

- This setting is disabled when output resolution is other than 1080p.

Lip Sync

You can set/adjust the Lip Sync (p. 35) function.

Auto*	This Player adjusts the Lip Sync function automatically.
Manual	You can adjust the Lip Sync function manually. You can set the delay of the audio for 2D and 3D contents independently.
	2D
	3D
Off	This Player does not adjust the Lip Sync function.

Video Process

Video Mode

You can select Video Mode below.

Standard*	The image is most natural and well-balanced. This mode suits for normal use.
Vivid	The image is more vivid and sharp.
Cinema	The image suits for watching movie in dark room.
Custom	You can adjust the visual image manually. Press ▲/▼ to select the parameter, then press ◀/▶ to adjust the figure.

Brightness

Adjusts the overall brightness of the image.

Saturation

Adjusts the richness of the color in the projected image.

Hue

Adjusts the tint of the projected image.

Contrast

Adjusts the bright areas (white levels) in the image.

Sharpness

Adjusts the sharpness of objects in the video.

CTI

Smooths out the edges of color images. Color images are rendered more distinct.

The default settings are 0.

Color Adjust

You can adjust Brightness/Saturation/Hue for each color (Red/Green/Blue/Yellow/Cyan/Magenta). To use this function, set Video Mode to Custom. For details on the setting items, see “Video Mode” (p. 27).

The default settings are 0.

Noise Reduction

You can set the Noise Reduction to a level of 0 to 3. 0 is off, and 3 is the maximum level.

0, 1, 2*, 3

De-interlacing Mode

You can select how to detect the video signal. Set to Auto for normal use. When horizontal stripping noise appears on the screen, set this to Film/Video to remove the noise.

Auto*, Film, Video

Audio Setting

The default settings are marked with “*”.

Audio Output

HDMI

You can select the output mode of HDMI terminal. For more details on output formats, refer to “About the audio output formats” (p. 28).

Bitstream*, PCM, Reencode, Off

Note

- To output HD audio (Dolby TrueHD or DTS-HD Master Audio) from HDMI terminal, set Video Out Select to Auto or more than 720p (p. 26).

DRC

You can set the DRC (Dynamic Range Compression) (p. 34) to on/off/Auto. When set to Auto, DRC is automatically turned on for a source with DRC information in Dolby TrueHD format. DRC makes the strong sound such as plosive sound lower, and conversations more audible. It is useful when you watch movies in the night.

Off, On, Auto*

System Information

Software version and MAC address (p. 35) are displayed.

■ About the audio output formats

Source format		HDMI		
		Bitstream	PCM	Reencode
PCM 2ch	with SA* or BCS**	PCM 2ch		Dolby Digital
	without SA* or BCS**	PCM 2ch		
PCM 5.1ch	with SA* or BCS**	PCM 5.1ch		Dolby Digital
	without SA* or BCS**	PCM 5.1ch		
PCM 7.1ch	with SA* or BCS**	PCM 7.1ch		Dolby Digital
	without SA* or BCS**	PCM 7.1ch		
Dolby Digital	with SA* or BCS**	Dolby Digital	PCM up to 5.1ch	Dolby Digital
	without SA* or BCS**			
Dolby Digital Plus	with SA* or BCS**	Dolby Digital Plus	PCM up to 7.1ch	Dolby Digital
	without SA* or BCS**			Dolby Digital Plus
Dolby TrueHD	with SA* or BCS**	Dolby TrueHD	PCM up to 7.1ch	Dolby Digital
	without SA* or BCS**			Dolby TrueHD
DTS	with SA* or BCS**	DTS	PCM up to 5.1ch	DTS
	without SA* or BCS**			
DTS HD High Resolution	with SA* or BCS**	DTS HD High Resolution	PCM up to 5.1ch (Core decode)	DTS
	without SA* or BCS**			DTS HD High Resolution
DTS-HD Master Audio	with SA* or BCS**	DTS-HD Master Audio	PCM up to 5.1ch (Core decode)	DTS
	without SA* or BCS**			DTS-HD Master Audio

* “SA” is a Secondary Audio.

** “BCS” is a button click sound, the sound effect for pop-up menus, etc.

Notes

- When HDMI is set to Bitstream, secondary audio is not output. (p. 27)
- To output HD audio (Dolby TrueHD or DTS-HD Master Audio) from HDMI terminal, set Video Out Select to Auto or more than 720p (p. 26).

■ About the video output formats

When TV System is set to NTSC

	Resolution	Auto	480i/576i	480p/576p	720p	1080i	1080p
HDMI	BD-Video with 1080p/24 Hz content	*1, *2	480i	480p	720p 60 Hz	1080i 60 Hz	1080p 24/60 Hz *2
	Others						1080p 60 Hz

When TV System is set to PAL

	Resolution	Auto	480i/576i	480p/576p	720p	1080i	1080p
HDMI	BD-Video with 1080p/24 Hz content	*1, *2	576i	576p	720p 50 Hz	1080i 50 Hz	1080p 24/50 Hz *2
	Others						1080p 50 Hz

*1 Resolution is set to the maximum resolution supported by the connected TV. For example, when the maximum resolution supported by the connected TV is 1080p, the resolution will be set to 1080p.

*2 If the source is 1080p 24 Hz content, and the connected TV supports 1080p 24 Hz content output, 1080p 24 Hz will be output instead of 1080p 50/60 Hz when resolution is set to Auto or 1080p, and Auto is set for HDMI 1080p 24Hz (p. 27) in Display Setting.

When TV System is set to Multi

When TV System is set to Multi, video signal is output at the same frequency as the source. Refer to the tables above for details on the frequency setting of the TV and resolution of the output video signal.

Notes

- HDMI 1080p 24Hz setting is disabled when output resolution is other than 1080p.
- When TV System is set to NTSC and video source is not 60 Hz, the video output signal is converted to 60 Hz.
- When TV System is set to PAL and video source is not 50 Hz, the video output signal is converted to 50 Hz.

Software upgrade

Some of the newly released Blu-ray Discs cannot be played back unless you upgrade this Player software to the latest version. We recommend upgrading the software of this Player with software upgrade so that this Player is operated based on the latest software.

To check for the availability of a software upgrade, visit <http://download.yamaha.com/>

Note

- Do not remove the USB memory device, set this Player to standby mode or unplug the power cable/LAN cable while the software upgrade is being performed.

■ Upgrading the software

1. Prepare for the software upgrade.

When you upgrade the software from USB Storage:

- ① Save the upgrade file package to the appropriate folder on the USB memory device. For more details, refer to the procedure document attached with the upgrade file package.
- ② Connect the USB memory device.
Skip step 2.

When you upgrade the software from Network:
Confirm that this Player is connected to the network.

2. Select the upgrade method and start upgrade from SETUP menu.

- ① Press **SETUP** to display SETUP menu screen.
- ② Select General Setting → System → Upgrade.
- ③ Select the item which contains the upgrade file package from USB Storage/Network.

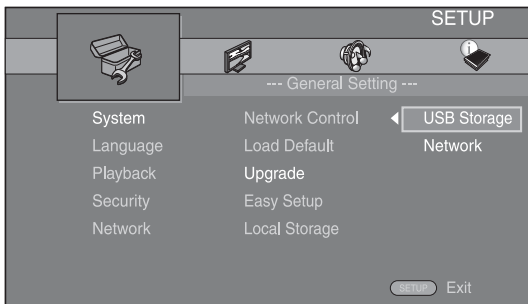

The system will search for upgrade file package.

3. Upgrade the software by following the on-screen messages.

Upgrade is completed. The system will be reset.





Troubleshooting

Refer to the table below when this Player does not function properly. If the problem you are experiencing is not listed below or if the instruction below does not help, turn off this Player, disconnect the power cable, and contact the nearest authorized Yamaha dealer or service center.

■ Power

Problem	Possible causes and solutions
No power.	<ul style="list-style-type: none"> – Connect the AC power cable properly. – Press  on the front panel to turn on the power.
The Player power is turned off.	<ul style="list-style-type: none"> – The power will be automatically turned off after 30 continuous minutes of inactivity (no playback).





■ Basic operation

Problem	Possible causes and solutions
The remote control does not work.	<ul style="list-style-type: none"> – Use the remote control within its operating range. (p. 9) – Replace the batteries. (p. 9)
Buttons do not work.	<ul style="list-style-type: none"> – Press and hold  on the front panel for more than 5 seconds, and release to reset this Player. – To completely reset this Player, unplug the power cable from the AC outlet for 10 seconds or more, plug the power cable to the AC outlet again, and then turn on this Player.
Password is forgotten.	<ul style="list-style-type: none"> – Press and hold  and  on the front panel simultaneously when no disc is inserted and playback is stopped to set all the settings including Security settings (p. 25) of this Player to their default settings. After the power is turned off automatically, press  to turn on the power again.

■ Disc playback

Problem	Possible causes and solutions
The Player cannot play a disc.	<ul style="list-style-type: none"> – Take out the disc and clean it. (p. 4) – Make sure that the disc is loaded properly (aligned in disc tray and label-side up). (p. 4) – Use a disc supported by the Player. (p. 3) – Remove the disc and then check whether the Player supports the disc or not. (p. 3) – Check the region code. (p. 3) – Check whether the disc is defective by trying another disc. – The CD-R/RW, DVD+R/RW/R DL, and DVD-R/RW/R DL must be finalized. (p. 3)
Video stops.	<ul style="list-style-type: none"> – The Player will stop if it senses shock or vibration.
The Player makes a snapping sound when starting playback or loading a disc.	<ul style="list-style-type: none"> – These sounds are not malfunctions of the Player but are normal operating conditions.

■ Picture

Problem	Possible causes and solutions
No picture.	<ul style="list-style-type: none"> - Make sure that the HDMI cable is connected correctly. (p. 10) - Make sure that the connected TV or the AV receiver is set to the correct input. (p. 10) - With no disc inserted, or playback stopped, press and hold  and  on the front panel simultaneously to set video resolution to the default value. <p>If a picture is still not output, press and hold  on the front panel for approximately 5 seconds to switch NTSC/PAL.</p>
Screen freezes and operation buttons do not work.	<ul style="list-style-type: none"> - Press , then restart playback. - Turn off the power and turn on the power again. - Press and hold  on the front panel for more than 5 seconds, and release to reset this Player.
Video is not output with the desired resolution.	<ul style="list-style-type: none"> - Set to the desired resolution. (p. 26)
Wide-screen video appears vertically stretched, or black bands appear at the top and bottom of the screen. Or 4:3 video appears horizontally stretched.	<ul style="list-style-type: none"> - Change the aspect ratio of your TV. (p. 26)
Square noise (mosaic) appears on the screen.	<ul style="list-style-type: none"> - Blocks in images may be visible in scenes with rapid movement due to the characteristics of digital image compression technology.
Audio is not output, or images are not played back properly.	<ul style="list-style-type: none"> - The audio may not be output or the images may not be played back properly for some discs in which copyright-protected contents are recorded.

■ Sound

Problem	Possible causes and solutions
No sound, or sound is distorted.	<ul style="list-style-type: none"> - Check that the HDMI cable is connected correctly. (p. 10) - Turn the volume of TV or AV receiver up. - There is no sound during still mode, fast forward, and fast reverse. (p. 8) - Audio may not be output depending on the audio recording status, such as when audio other than an audio signal or non-standard audio is recorded for the audio content. (p. 3)
Left and right channels of audio are reversed, or sound comes out of only one side.	<ul style="list-style-type: none"> - Check the HDMI connection. (p. 10)
Audio is not output, or images are not played back properly.	<ul style="list-style-type: none"> - The audio may not be output or the images may not be played back properly for some discs in which copyright-protected contents are recorded.
Cannot hear the sound of PIP (secondary audio).	<ul style="list-style-type: none"> - Set HDMI to PCM/Reencode. (p. 27) - To hear secondary audio, press 2ND AUDIO. (p. 6) - Depending on the disc, you may need to set secondary audio on the top menu of the disc. (p. 8)

■ Network

Problem	Possible causes and solutions
Cannot connect to the Internet.	<ul style="list-style-type: none"> - Connect the Network cable properly. - Turn on the connected equipment, such as broadband router or modem. - Connect the broadband router and/or modem properly. - Set the proper value(s) in the network setting. Check "Network". (p. 25)
Cannot download BD-Live contents.	<ul style="list-style-type: none"> - Connect the Network cable properly. (p. 11) - Connect USB memory device properly. Check that the USB memory device is connected to the USB connector of this Player. (p. 11) - Check if the Blu-ray Disc supports BD-Live. - Check the setting for "Internet Connection". (p. 25) - Connect the USB memory device formatted in FAT16, FAT32, or NTFS. - It is recommended to connect the USB memory device with at least 2 GB of free space. If there is not enough free space, format the USB memory device. (p. 24) - Refer to the supplied user's manual of the disc or consult the disc manufacturer.
Cannot detect the DLNA server.	<ul style="list-style-type: none"> - Connect the network cable properly. - Turn on the connected equipment, such as broadband router or the server. - Confirm the Player and the server are connected to the same access point. - Set the proper value(s) in the network setting. Check "Network". (p. 25) - Depending on the DLNA server, the Player may need to be permitted from the server. - Depending on the DLNA server, it needs to change a firewall setting.
Cannot play the file on the home network server.	<ul style="list-style-type: none"> - Make sure the file is playable. (p. 3) - Check your DLNA server's setting. - The playback and operating quality may be affected by your home network condition.

■ Messages on the screen

- The following messages appear on the TV screen in case the disc you tried to play back is not appropriate or the operation is not correct.

Error message	Possible causes and solutions
Unsupported File	- The file is not supported with this Player. See "Types of discs/files that can be used with this Player" (p. 3).
Wrong region code!	- The disc is an incompatible region code. See "Region management information for Blu-ray Disc/DVD videos" (p. 3).
Network has FAILED.	- This Player cannot be connected to the network. Check connection (p. 11) and Network setting (p. 25).
Network is OK, proxy has FAILED.	- This Player cannot be connected to the proxy server. See "Proxy Setting" (p. 25).
BD-Live connection is prohibited in SETUP menu.	- BD-Live connection is prohibited. See "BD-Live Connection" (p. 25).
Upgrade has failed for some reason!	- Upgrade is failed. Check if the upgrade file is corrupted or unreadable.

Glossary

AVCHD

AVCHD is a new format (standard) for high definition video cameras that can be used to record and play high-resolution HD images.

BD-Live™

BD-Live is a Blu-ray Disc standard that utilizes a network connection, enabling this Player to go online to download promotional videos and other data.

BDMV

BDMV (Blu-ray Disc Movie) refers to one of the application formats used for BD-ROM which is one of the Blu-ray Disc specifications. BDMV is a recording format equivalent to DVD-Video of the DVD specification.

Blu-ray 3D™

Blu-ray 3D enables you to view full high definition 3D images.

BONUSVIEW™

BONUSVIEW compatible discs let you simultaneously enjoy video sub-channel for two screens, audio sub-channel and sub-titles. A small screen appears within the main screen during playback (Picture in Picture).

Color Space

Color Space is a color range that can be represented. RGB is a color space based on the RGB color model (red, green and blue) and is typically used for PC monitors. YCbCr is a color space based on a luminance signal (Y) and two color difference signals (Cb and Cr).

Deep Color

Deep Color refers to the use of various color depths in displays, up from the 24-bit depths in previous versions of the HDMI specification. This extra bit depth allows HDTVs and other displays go from millions of colors to billions of colors and eliminate on-screen color banding for smooth tonal transitions and subtle gradations between colors. The increased contrast ratio can represent many times more shades of gray between black and white. Also Deep Color increases the number of available colors within the boundaries defined by the RGB or YCbCr color space.

DLNA

DLNA (Digital Living Network Alliance) provides easy sharing of digital media through network in the home, and you can enjoy digital contents stored on your DLNA-server-software-installed PC or other DLNA compatible device with your TV via this Player. To connect this Player to your DLNA servers, some settings for the DLNA server or device are required. For details, refer to your DLNA server software or DLNA device.

Dolby Digital

A sound system developed by Dolby Laboratories Inc. that gives movie theater ambience to audio output when the product is connected to a Dolby Digital processor or amplifier.

Dolby Digital Plus

A sound system developed as an extension to Dolby Digital. This audio coding technology supports 7.1 multi-channel surround sound.

Dolby TrueHD

Dolby TrueHD is a lossless coding technology that supports up to 8 channels of multi-channel surround sound for the next generation optical discs. The reproduced sound is true to the original source bit-for-bit.

DRC (Dynamic Range Control)

DRC lets you adjust the range between the loudest and softest sounds (dynamic range) for playback at average volume. Use this when it is hard to hear dialog, or during times when playback may disturb neighbors.

DTS

This is a digital sound system developed by DTS, Inc. for use in cinemas.

DTS-HD High Resolution Audio

DTS-HD High Resolution Audio is a new technology developed for the next generation high definition optical disc format.

DTS-HD Master Audio

DTS-HD Master Audio is a lossless audio compression technology developed for the next generation high definition optical disc format.

FLAC

FLAC (Free Lossless Audio Codec) is an open file format for lossless audio data compression. While inferior in compression rate to other lossy compressed audio formats, it can often provide higher audio quality.

HDMI

HDMI (High-Definition Multimedia Interface) is an interface that supports both video and audio on a single digital connection. The HDMI connection carries standard to high definition video signals and multi-channel audio signals to AV components such as HDMI equipped TVs, in digital form without degradation.

Letterbox (LB 4:3)

A screen size with black bars on the top and bottom of the image to allow viewing of wide-screen (16:9) material on a connected 4:3 TV.

Linear PCM Sound

Linear PCM is a signal recording format used for Audio CDs and on some DVD and Blu-ray Discs. The sound on Audio CDs is recorded at 44.1 kHz with 16 bits. (Sound is recorded between 48 kHz with 16 bits and 96 kHz with 24 bits on DVD discs and between 48 kHz with 16 bits and 192 kHz with 24 bits on Blu-ray Discs.)

Lip Sync

Lip Sync, an abbreviation for lip synchronization, is a technical term that involves both a problem and a capability of maintaining audio and video signals synchronized during post-production and transmission. Whereas the audio and video latency requires complex end-user adjustments, HDMI incorporates an automatic audio and video syncing capability that allows devices to perform this synchronization automatically and accurately without user interaction.

Mac address

The Mac address is a unique value assigned to a network device for identification purposes.

Pan Scan (PS 4:3)

A screen size that cuts off the sides of the image to allow viewing of wide-screen (16:9) material on a connected 4:3 TV.

Subtitles

These are the lines of text appearing at the bottom of the screen which translate or transcribe the dialog. They are recorded on many DVDs and Blu-ray Discs.

x.v.Color

x.v.Color reproduces a greater range of color than before, showing almost all of the colors that the human eye can detect.

Specifications

■ General

Power supply	
[U.S.A. and Canada models]	AC 110–240 V, 60 Hz
[Central and South America model]	AC 110–240 V, 50/60 Hz
[Australia model]	AC 110–240 V, 50 Hz
[U.K., Europe and Russia model]	AC 110–240 V, 50 Hz
[China model]	AC 110–240 V, 50 Hz
[Asia model]	AC 110–240 V, 50/60 Hz
[Korea model]	AC 110–240 V, 60 Hz
Power consumption (Normal)	18 W
Power consumption (Standby)	0.5 W or less
Dimensions (W × H × D)	435 × 50 × 202 mm (17-1/8 × 2 × 8 in)
Weight	2.0 kg (4.4 lbs.)

■ Input/output

HDMI output	Type A connector × 1 480i/576i/480p/576p/720p/1080i/1080p/1080p@24Hz, Deep Color, x.v. Color support
USB	Type A connector × 2
Other equipment	Ethernet × 1

Specifications are subject to change without notice.

■ Copyright

- Audio-visual material may consist of copyrighted works which must not be recorded without the authority of the owner of the copyright. Refer to relevant laws in your country.
- Manufactured under license from Dolby Laboratories. Dolby and the double-D symbol are trademarks of Dolby Laboratories.
- Manufactured under license under U.S. Patent Nos: 5,956,674; 5,974,380; 6,487,535 & other U.S. and worldwide patents issued & pending. DTS, the Symbol, & DTS and the Symbol together are registered trademarks & DTS Digital Surround and the DTS logos are trademarks of DTS, Inc. Product includes software. © DTS, Inc. All Rights Reserved.
- “Blu-ray Disc™”, “Blu-ray™”, “Blu-ray 3D™”, “BD-Live™”, “BONUSVIEW™”, and the logos are trademarks of the Blu-ray Disc Association.
-  is a trademark of DVD Format/Logo Licensing Corporation.
- “HDMI,” the “HDMI” logo and “High-Definition Multimedia Interface” are trademarks, or registered trademarks of HDMI Licensing LLC.
- “x.v.Color” and “x.v.Color” logo are trademarks of Sony Corporation.
- “AVCHD” and the “AVCHD” logo are trademarks of Panasonic Corporation and Sony Corporation.
- Java and all Java-based trademarks and logos are trademarks or registered trademarks of Sun Microsystems, Inc. in the United States and/or other countries.
- This product is licensed under the AVC patent portfolio license and VC-1 patent portfolio license for the personal and non-commercial use of a consumer to (i) encode video in compliance with the AVC Standard and VC-1 Standard (“AVC/VC-1 Video”) and/or (ii) decode AVC/VC-1 Video that was encoded by a consumer engaged in a personal and non-commercial activity and/or was obtained from a video provider licensed to provide AVC/VC-1 Video. No license is granted or shall be implied for any other use. Additional information may be obtained from MPEG LA, LLC. See <http://www.mpegla.com>.
- Windows Media Player is a registered trademark or trademark of Microsoft corporation in the United States and/or other countries.
- YouTube and the YouTube logo are trademarks of Google. Inc.
- DLNA and DLNA CERTIFIED are trademarks and/or service marks of Digital Living Network Alliance.
- Copyright 2004-2010 Verance Corporation. Cinavia™ is a Verance Corporation trademark. Protected by U.S. Patent 7,369,677 and worldwide patents issued and pending under license from Verance Corporation. All rights reserved.

Index

■ Numerics

2ND AUDIO, remote control	6
3D Output, SETUP menu	26
3D Playback Message, SETUP menu	24

■ A

A/B, remote control	7
Angle Mark, SETUP menu	25
Angle, On Screen menu	17
ANGLE, remote control	7
Audio file requirement	3
Audio output formats	28
Audio Output, SETUP menu	27
Audio Setting, SETUP menu	27
Audio, On Screen menu	17
AUDIO, remote control	7
Audio, SETUP menu	24

■ B

BD-Live	20
BD-Live Connection, SETUP menu	25
Bitrate, On Screen menu	17
Bookmark	19

■ C

Change Password, SETUP menu	25
Chapter, On Screen menu	17
CLEAR, remote control	7
Color Adjust, SETUP menu	27
Color buttons, remote control	7
Color Space, SETUP menu	26
Connection Test, SETUP menu	25
Control buttons, remote control	8
Country Code, SETUP menu	25
Cursor buttons, remote control	8

■ D

Data disc playback	13
De-interlacing Mode, SETUP menu	27
DIGEST, remote control	7
Disc Auto Playback, SETUP menu	24
Disc precautions	4
Display Setting, SETUP menu	26
DLNA, SETUP menu	25
DRC, SETUP menu	27

■ E

Easy Setup	12
Easy Setup, SETUP menu	24
ENTER, remote control	6, 8

■ G

General Setting, SETUP menu	24
-----------------------------------	----

■ H

HDMI 1080p 24Hz, SETUP menu	27
HDMI connection	10
HDMI Control function	24
HDMI Control, SETUP menu	24
HDMI Deep Color, SETUP menu	26

HDMI, SETUP menu	27
HOME menu	13
HOME, remote control	7

■ I

Information, SETUP menu	25
Initial Wizard	12
Ins Replay, On Screen menu	17
Ins Search, On Screen menu	17
Internet Connection, SETUP menu	25
IP Setting, SETUP menu	25

■ L

Language, SETUP menu	24
Last Memory, SETUP menu	25
Lip Sync, SETUP menu	27
Load Default, SETUP menu	24
Local Storage, SETUP menu	24

■ M

MARKER, remote control	6
MEDIA menu	13
Menu, SETUP menu	24
Mode/Play Mode, On Screen menu	17

■ N

Network connection	11
Network, SETUP menu	25
Noise Reduction, SETUP menu	27
Number buttons, remote control	6

■ O

On Screen menu	17
ON SCREEN, remote control	8
OSD, SETUP menu	24

■ P

Parental Control, SETUP menu	25
PIP Mark, SETUP menu	25
PIP, remote control	6
Playback, SETUP menu	25
POP UP/MENU, remote control	8
Program play	19
PROGRAM, remote control	6
Proxy Setting, SETUP menu	25

■ R

Remote control	6
REPEAT, remote control	6
RETURN, remote control	8

■ S

Screen Saver, SETUP menu	24
Search function	19
SEARCH, remote control	7
Second Audio, On Screen menu	17
Second Video, On Screen menu	17
Secondary Audio Mark, SETUP menu	25
Security, SETUP menu	25
SETUP menu	21

SETUP menu operation	23
SETUP, remote control	7
SHUFFLE, remote control	6
Slide Show, On Screen menu	17
Software upgrade	30
Status menu	18
STATUS, remote control	6
Subtitle Style, On Screen menu	17
Subtitle, On Screen menu	17
SUBTITLE, remote control	6
Subtitle, SETUP menu	24
Supplied parts	2
System Information, SETUP menu	27
System, SETUP menu	24

■ T

Time, On Screen menu	17
Title, On Screen menu	17
TOP MENU, remote control	8
Track/File, On Screen menu	17
Transition, On Screen menu	17
Troubleshooting	31
TV Screen, SETUP menu	26
TV System, SETUP menu	26
TV, SETUP menu	26

■ U

Upgrade of software	30
Upgrade, SETUP menu	24
USB connection	11
USB content playback	13
Using Picture in Picture function	20

■ V

Video Mode, SETUP menu	27
Video Out Select, SETUP menu	26
Video output formats	29
Video Process, SETUP menu	27

■ Y

YouTube playback	16
------------------------	----

■ Z

ZOOM, remote control	7
----------------------------	---

Information about software

This product uses the following software.
For information (copyright, etc) about each software, read the original sentences stated below.

■ About Linux, Busybox, SquashFS, LIRC, U-boot, gdb, mtd-utils

GNU GENERAL PUBLIC LICENSE
Version 2, June 1991

Copyright (C) 1989, 1991 Free Software Foundation, Inc.
51 Franklin St, Fifth Floor, Boston, MA 02110-1301 USA

Everyone is permitted to copy and distribute verbatim copies of this license document, but changing it is not allowed.

Preamble

The licenses for most software are designed to take away your freedom to share and change it. By contrast, the GNU General Public License is intended to guarantee your freedom to share and change free software—to make sure the software is free for all users. This General Public License applies to most of the Free Software Foundation's software and to any other program whose authors commit to using it. (Some other Free Software Foundation software is covered by the GNU Library General Public License instead.) You can apply it to your programs, too.

When we speak of free software, we are referring to freedom, not price. Our General Public Licenses are designed to make sure that you have the freedom to distribute copies of free software (and charge for this service if you wish), that you receive source code or can get it if you want it, that you can change the software or use pieces of it in new free programs; and that you know you can do these things.

To protect your rights, we need to make restrictions that forbid anyone to deny you these rights or to ask you to surrender the rights. These restrictions translate to certain responsibilities for you if you distribute copies of the software, or if you modify it.

For example, if you distribute copies of such a program, whether gratis or for a fee, you must give the recipients all the rights that you have. You must make sure that they, too, receive or can get the source code. And you must show them these terms so they know their rights.

We protect your rights with two steps: (1) copyright the software, and (2) offer you this license which gives you legal permission to copy, distribute and/or modify the software. Also, for each author's protection and ours, we want to make certain that everyone understands that there is no warranty for this free software. If the software is modified by someone else and passed on, we want its recipients to know that what they have is not the original, so that any problems introduced by others will not reflect on the original authors' reputations.

Finally, any free program is threatened constantly by software patents. We wish to avoid the danger that redistributors of a free program will individually obtain patent licenses, in effect making the program proprietary. To prevent this, we have made it clear that any patent must be licensed for everyone's free use or not licensed at all. The precise terms and conditions for copying, distribution and modification follow.

GNU GENERAL PUBLIC LICENSE TERMS AND CONDITIONS FOR COPYING, DISTRIBUTION AND MODIFICATION

0. This License applies to any program or other work which contains a notice placed by the copyright holder saying it may be distributed under the terms of this General Public License. The "Program", below, refers to any such program or work, and a "work based on the Program" means either the Program or any derivative work under copyright law: that is to say, a work containing the Program or a portion of it, either verbatim or with modifications and/or translated into another language. (Hereinafter, translation is included without limitation in the term "modification".) Each licensee is addressed as "you".

Activities other than copying, distribution and modification are not covered by this License; they are outside its scope. The act of running the Program is not restricted, and the output from the Program is covered only if its contents constitute a work based on the Program (independent of having been made by running the Program). Whether that is true depends on what the Program does.

1. You may copy and distribute verbatim copies of the Program's source code as you receive it, in any medium, provided that you conspicuously and appropriately publish on each copy an appropriate copyright notice and disclaimer of warranty; keep intact all the notices that refer to this License and to the absence of any warranty; and give any other recipients of the Program a copy of this License along with the Program.

You may charge a fee for the physical act of transferring a copy, and you may at your option offer warranty protection in exchange for a fee.

2. You may modify your copy or copies of the Program or any portion of it, thus forming a work based on the Program, and copy and distribute such modifications or work under the terms of Section 1 above, provided that you also meet all of these conditions:

- You must cause the modified files to carry prominent notices stating that you changed the files and the date of any change.
- You must cause any work that you distribute or publish, that in whole or in part contains or is derived from the Program or any part thereof, to be licensed as a whole at no charge to all third parties under the terms of this License.

- If the modified program normally reads commands interactively when run, you must cause it, when started running for such interactive use in the most ordinary way, to print or display an announcement including an appropriate copyright notice and a notice that there is no warranty (or else, saying that you provide a warranty) and that users may redistribute the program under these conditions, and telling the user how to view a copy of this License. (Exception: if the Program itself is interactive but does not normally print such an announcement, your work based on the Program is not required to print an announcement.)

These requirements apply to the modified work as a whole. If identifiable sections of that work are not derived from the Program, and can be reasonably considered independent and separate works in themselves, then this License, and its terms, do not apply to those sections when you distribute them as separate works. But when you distribute the same sections as part of a whole which is a work based on the Program, the distribution of the whole must be on the terms of this License, whose permissions for other licensees extend to the entire whole, and thus to each and every part regardless of who wrote it.

Thus, it is not the intent of this section to claim rights or contest your rights to work written entirely by you; rather, the intent is to exercise the right to control the distribution of derivative or collective works based on the Program.

In addition, mere aggregation of another work not based on the Program with the Program (or with a work based on the Program) on a volume of a storage or distribution medium does not bring the other work under the scope of this License.

- You may copy and distribute the Program (or a work based on it, under Section 2) in object code or executable form under the terms of Sections 1 and 2 above provided that you also do one of the following:
 - Accompany it with the complete corresponding machine-readable source code, which must be distributed under the terms of Sections 1 and 2 above on a medium customarily used for software interchange; or,
 - Accompany it with a written offer, valid for at least three years, to give any third party, for a charge no more than your cost of physically performing source distribution, a complete machine-readable copy of the corresponding source code, to be distributed under the terms of Sections 1 and 2 above on a medium customarily used for software interchange; or,
 - Accompany it with the information you received as to the offer to distribute corresponding source code. (This alternative is allowed only for noncommercial distribution and only if you received the program in object code or executable form with such an offer, in accord with Subsection b above.)

The source code for a work means the preferred form of the work for making modifications to it. For an executable work, complete source code means all the source code for all modules it contains, plus any associated interface definition files, plus the scripts used to control compilation and installation of the executable. However, as a special exception, the source code distributed need not include anything that is normally distributed (in either source or binary form) with the major components (compiler, kernel, and so on) of the operating system on which the executable runs, unless that component itself accompanies the executable.

If distribution of executable or object code is made by offering access to copy from a designated place, then offering equivalent access to copy the source code from the same place counts as distribution of the source code, even though third parties are not compelled to copy the source along with the object code.

- You may not copy, modify, sublicense, or distribute the Program except as expressly provided under this License. Any attempt otherwise to copy, modify, sublicense or distribute the Program is void, and will automatically terminate your rights under this License. However, parties who have received copies, or rights, from you under this License will not have their licenses terminated so long as such parties remain in full compliance.
- You are not required to accept this License, since you have not signed it. However, nothing else grants you permission to modify or distribute the Program or its derivative works. These actions are prohibited by law if you do not accept this License. Therefore, by modifying or distributing the Program (or any work based on the Program), you indicate your acceptance of this License to do so, and all its terms and conditions for copying, distributing or modifying the Program or works based on it.
- Each time you redistribute the Program (or any work based on the Program), the recipient automatically receives a license from the original licensor to copy, distribute or modify the Program subject to these terms and conditions. You may not impose any further restrictions on the recipients' exercise of the rights granted herein. You are not responsible for enforcing compliance by third parties to this License.
- If, as a consequence of a court judgment or allegation of patent infringement or for any other reason (not limited to patent issues), conditions are imposed on you (whether by court order, agreement or otherwise) that contradict the conditions of this License, they do not excuse you from the conditions of this License. If you cannot distribute so as to satisfy simultaneously your obligations under this License and any other pertinent obligations, then as a consequence you may not distribute the Program at all. For example, if a patent license would not permit royalty-free redistribution of the Program by all those who receive copies directly or indirectly through you, then the only way you could satisfy both it and this License would be to refrain entirely from distribution of the Program.

If any portion of this section is held invalid or unenforceable under any particular circumstance, the balance of the section is intended to apply and the section as a whole is intended to apply in other circumstances.

It is not the purpose of this section to induce you to infringe any patents or other property right claims or to contest validity of any such claims; this section has the sole purpose of protecting the integrity of the free software distribution system, which is implemented by public license practices. Many people have made generous contributions to the wide range of software distributed through that system in reliance on consistent application of that system; it is up to the author/donor to decide if he or she is willing to distribute software through any other system and a licensee cannot impose that choice.

This section is intended to make thoroughly clear what is believed to be a consequence of the rest of this License.

8. If the distribution and/or use of the Program is restricted in certain countries either by patents or by copyrighted interfaces, the original copyright holder who places the Program under this License may add an explicit geographical distribution limitation excluding those countries, so that distribution is permitted only in or among countries not thus excluded. In such case, this License incorporates the limitation as if written in the body of this License.

9. The Free Software Foundation may publish revised and/or new versions of the General Public License from time to time. Such new versions will be similar in spirit to the present version, but may differ in detail to address new problems or concerns.

Each version is given a distinguishing version number. If the Program specifies a version number of this License which applies to it and "any later version", you have the option of following the terms and conditions either of that version or of any later version published by the Free Software Foundation. If the Program does not specify a version number of this License, you may choose any version ever published by the Free Software Foundation.

10. If you wish to incorporate parts of the Program into other free programs whose distribution conditions are different, write to the author to ask for permission. For software which is copyrighted by the Free Software Foundation, write to the Free Software Foundation; we sometimes make exceptions for this. Our decision will be guided by the two goals of preserving the free status of all derivatives of our free software and of promoting the sharing and reuse of software generally.

NO WARRANTY

11. BECAUSE THE PROGRAM IS LICENSED FREE OF CHARGE, THERE IS NO WARRANTY FOR THE PROGRAM, TO THE EXTENT PERMITTED BY APPLICABLE LAW. EXCEPT WHEN OTHERWISE STATED IN WRITING THE COPYRIGHT HOLDERS AND/OR OTHER PARTIES PROVIDE THE PROGRAM "AS IS" WITHOUT WARRANTY OF ANY KIND, EITHER EXPRESSED OR IMPLIED, INCLUDING, BUT NOT LIMITED TO, THE IMPLIED WARRANTIES OF MERCHANTABILITY AND FITNESS FOR A PARTICULAR PURPOSE. THE ENTIRE RISK AS TO THE QUALITY AND PERFORMANCE OF THE PROGRAM IS WITH YOU. SHOULD THE PROGRAM PROVE DEFECTIVE, YOU ASSUME THE COST OF ALL NECESSARY SERVICING, REPAIR OR CORRECTION.

12. IN NO EVENT UNLESS REQUIRED BY APPLICABLE LAW OR AGREED TO IN WRITING WILL ANY COPYRIGHT HOLDER, OR ANY OTHER PARTY WHO MAY MODIFY AND/OR REDISTRIBUTE THE PROGRAM AS PERMITTED ABOVE, BE LIABLE TO YOU FOR DAMAGES, INCLUDING ANY GENERAL, SPECIAL, INCIDENTAL OR CONSEQUENTIAL DAMAGES ARISING OUT OF THE USE OR INABILITY TO USE THE PROGRAM (INCLUDING BUT NOT LIMITED TO LOSS OF DATA OR DATA BEING RENDERED INACCURATE OR LOSSES SUSTAINED BY YOU OR THIRD PARTIES OR A FAILURE OF THE PROGRAM TO OPERATE WITH ANY OTHER PROGRAMS), EVEN IF SUCH HOLDER OR OTHER PARTY HAS BEEN ADVISED OF THE POSSIBILITY OF SUCH DAMAGES.

END OF TERMS AND CONDITIONS

How to Apply These Terms to Your New Programs

If you develop a new program, and you want it to be of the greatest possible use to the public, the best way to achieve this is to make it free software which everyone can redistribute and change under these terms.

To do so, attach the following notices to the program. It is safest to attach them to the start of each source file to most effectively convey the exclusion of warranty; and each file should have at least the "copyright" line and a pointer to where the full notice is found.

<one line to give the program's name and a brief idea of what it does.>
Copyright (C) <year> <name of author>

This program is free software; you can redistribute it and/or modify it under the terms of the GNU General Public License as published by the Free Software Foundation; either version 2 of the License, or (at your option) any later version.

This program is distributed in the hope that it will be useful, but WITHOUT ANY WARRANTY; without even the implied warranty of MERCHANTABILITY or FITNESS FOR A PARTICULAR PURPOSE. See the GNU General Public License for more details.

You should have received a copy of the GNU General Public License along with this program; if not, write to the Free Software Foundation, Inc., 51 Franklin St, Fifth Floor, Boston, MA 02110-1301 USA

Also add information on how to contact you by electronic and paper mail.

If the program is interactive, make it output a short notice like this when it starts in an interactive mode:

Gnomovision version 69, Copyright (C) year name of author Gnomovision comes with ABSOLUTELY NO WARRANTY; for details type 'show w'. This is free software, and you are welcome to redistribute it under certain conditions; type 'show c' for details.

The hypothetical commands 'show w' and 'show c' should show the appropriate parts of the General Public License. Of course, the commands you use may be called something other than 'show w' and 'show c'; they could even be mouse-clicks or menu items--whatever suits your program.

You should also get your employer (if you work as a programmer) or your school, if any, to sign a "copyright disclaimer" for the program, if necessary. Here is a sample; alter the names:

Yoyodyne, Inc., hereby disclaims all copyright interest in the program 'Gnomovision' (which makes passes at compilers) written by James Hacker.

<signature of Ty Coon>, 1 April 1989

Ty Coon, President of Vice

This General Public License does not permit incorporating your program into proprietary programs. If your program is a subroutine library, you may consider it more useful to permit linking proprietary applications with the library. If this is what you want to do, use the GNU Library General Public License instead of this License..

■ About glibc, libmtp, libusb, libusb-compat, DirectFB, SawMan

GNU LESSER GENERAL PUBLIC LICENSE
Version 2.1, February 1999

Copyright (C) 1991, 1999 Free Software Foundation, Inc.
59 Temple Place, Suite 330, Boston, MA 02111-1307 USA

Everyone is permitted to copy and distribute verbatim copies of this license document, but changing it is not allowed.

[This is the first released version of the Lesser GPL. It also counts as the successor of the GNU Library Public License, version 2, hence the version number 2.1.]

Preamble

The licenses for most software are designed to take away your freedom to share and change it. By contrast, the GNU General Public Licenses are intended to guarantee your freedom to share and change free software--to make sure the software is free for all its users.

This license, the Lesser General Public License, applies to some specially designated software packages--typically libraries--of the Free Software Foundation and other authors who decide to use it. You can use it too, but we suggest you first think carefully about whether this license or the ordinary General Public License is the better strategy to use in any particular case, based on the explanations below.

When we speak of free software, we are referring to freedom of use, not price. Our General Public Licenses are designed to make sure that you have the freedom to distribute copies of free software (and charge for this service if you wish); that you receive source code or can get it if you want it; that you can change the software and use pieces of it in new free programs; and that you are informed that you can do these things.

To protect your rights, we need to make restrictions that forbid distributors to deny you these rights or to ask you to surrender these rights. These restrictions translate to certain responsibilities for you if you distribute copies of the library or if you modify it. For example, if you distribute copies of the library, whether gratis or for a fee, you must give the recipients all the rights that we gave you. You must make sure that they, too, receive or can get the source code. If you link other code with the library, you must provide complete object files to the recipients, so that they can relink them with the library after making changes to the library and recompiling it. And you must show them these terms so they know their rights.

We protect your rights with a two-step method: (1) we copyright the library, and (2) we offer you this license, which gives you legal permission to copy, distribute and/or modify the library.

To protect each distributor, we want to make it very clear that there is no warranty for the free library. Also, if the library is modified by someone else and passed on, the recipients should know that what they have is not the original version, so that the original author's reputation will not be affected by problems that might be introduced by others.

Finally, software patents pose a constant threat to the existence of any free program. We wish to make sure that a company cannot effectively restrict the users of a free program by obtaining a restrictive license from a patent holder. Therefore, we insist that any patent license obtained for a version of the library must be consistent with the full freedom of use specified in this license.

Most GNU software, including some libraries, is covered by the ordinary GNU General Public License. This license, the GNU Lesser General Public License, applies to certain designated libraries, and is quite different from the ordinary General Public License. We use this license for certain libraries in order to permit linking those libraries into non-free programs.

When a program is linked with a library, whether statically or using a shared library, the combination of the two is legally speaking a combined work, a derivative of the original library. The ordinary General Public License therefore permits such linking only if the entire combination fits its criteria of freedom. The Lesser General Public License permits more lax criteria for linking other code with the library.

We call this license the "Lesser" General Public License because it does Less to protect the user's freedom than the ordinary General Public License. It also provides other free software developers Less of an advantage over competing non-free programs. These disadvantages are the reason we use the ordinary General Public License for many libraries. However, the Lesser license provides advantages in certain special circumstances.

For example, on rare occasions, there may be a special need to encourage the widest possible use of a certain library, so that it becomes a de-facto standard. To achieve this, non-free programs must be allowed to use the library. A more frequent case is that a free library does the same job as widely used non-free libraries. In this case, there is little to gain by limiting the free library to free software only, so we use the Lesser General Public License.

In other cases, permission to use a particular library in non-free programs enables a greater number of people to use a large body of free software. For example, permission to use the GNU C Library in non-free programs enables many more people to use the whole GNU operating system, as well as its variant, the GNU/Linux operating system. Although the Lesser General Public License is less protective of the users' freedom, it does ensure that the user of a program that is linked with the Library has the freedom and the wherewithal to run that program using a modified version of the Library. The precise terms and conditions for copying, distribution and modification follow. Pay close attention to the difference between a "work based on the library" and a "work that uses the library". The former contains code derived from the library, whereas the latter must be combined with the library in order to run.

GNU LESSER GENERAL PUBLIC LICENSE

TERMS AND CONDITIONS FOR COPYING, DISTRIBUTION AND MODIFICATION

0. This License Agreement applies to any software library or other program which contains a notice placed by the copyright holder or other authorized party saying it may be distributed under the terms of this Lesser General Public License (also called "this License"). Each licensee is addressed as "you".

A "library" means a collection of software functions and/or data prepared so as to be conveniently linked with application programs (which use some of those functions and data) to form executables.

The "Library", below, refers to any such software library or work which has been distributed under these terms. A "work based on the Library" means either the Library or any derivative work under copyright law: that is to say, a work containing the Library or a portion of it, either verbatim or with modifications and/or translated straightforwardly into another language. (Hereinafter, translation is included without limitation in the term "modification".)

"Source code" for a work means the preferred form of the work for making modifications to it. For a library, complete source code means all the source code for all modules it contains, plus any associated interface definition files, plus the scripts used to control compilation and installation of the library.

Activities other than copying, distribution and modification are not covered by this License; they are outside its scope. The act of running a program using the Library is not restricted, and output from such a program is covered only if its contents constitute a work based on the Library (independent of the use of the Library in a tool for writing it). Whether that is true depends on what the Library does and what the program that uses the Library does.

1. You may copy and distribute verbatim copies of the Library's complete source code as you receive it, in any medium, provided that you conspicuously and appropriately publish on each copy an appropriate copyright notice and disclaimer of warranty; keep intact all the notices that refer to this License and to the absence of any warranty; and distribute a copy of this License along with the Library.

You may charge a fee for the physical act of transferring a copy, and you may at your option offer warranty protection in exchange for a fee.

2. You may modify your copy or copies of the Library or any portion of it, thus forming a work based on the Library, and copy and distribute such modifications or work under the terms of Section 1 above, provided that you also meet all of these conditions:

- The modified work must itself be a software library.
- You must cause the files modified to carry prominent notices stating that you changed the files and the date of any change.
- You must cause the whole of the work to be licensed at no charge to all third parties under the terms of this License.
- If a facility in the modified Library refers to a function or a table of data to be supplied by an application program that uses the facility, other than as an argument passed when the facility is invoked, then you must make a good faith effort to ensure that, in the event an application does not supply such function or table, the facility still operates, and performs whatever part of its purpose remains meaningful.

(For example, a function in a library to compute square roots has a purpose that is entirely well-defined independent of the application. Therefore, Subsection 2d requires that any application-supplied function or table used by this function must be optional: if the application does not supply it, the square root function must still compute square roots.)

These requirements apply to the modified work as a whole. If identifiable sections of that work are not derived from the Library, and can be reasonably considered independent and separate works in themselves, then this License, and its terms, do not apply to those sections when you distribute them as separate works. But when you distribute the same sections as part of a whole which is a work based on the Library, the distribution of the whole must be on the terms of this License, whose permissions for other licensees extend to the entire whole, and thus to each and every part regardless of who wrote it.

Thus, it is not the intent of this section to claim rights or contest your rights to work written entirely by you; rather, the intent is to exercise the right to control the distribution of derivative or collective works based on the Library.

In addition, mere aggregation of another work not based on the Library with the Library (or with a work based on the Library) on a volume of a storage or distribution medium does not bring the other work under the scope of this License.

3. You may opt to apply the terms of the ordinary GNU General Public License instead of this License to a given copy of the Library. To do this, you must alter all the notices that refer to this License, so that they refer to the ordinary GNU General Public License, version 2, instead of to this License. (If a newer version than version 2 of the ordinary GNU General Public License has appeared, then you can specify that version instead if you wish.) Do not make any other change in these notices.

Once this change is made in a given copy, it is irreversible for that copy, so the ordinary GNU General Public License applies to all subsequent copies and derivative works made from that copy.

This option is useful when you wish to copy part of the code of the Library into a program that is not a library.

4. You may copy and distribute the Library (or a portion or derivative of it, under Section 2) in object code or executable form under the terms of Sections 1 and 2 above provided that you accompany it with the complete corresponding machine-readable source code, which must be distributed under the terms of Sections 1 and 2 above on a medium customarily used for software interchange.

If distribution of object code is made by offering access to copy from a designated place, then offering equivalent access to copy the source code from the same place satisfies the requirement to distribute the source code, even though third parties are not compelled to copy the source along with the object code.

5. A program that contains no derivative of any portion of the Library, but is designed to work with the Library by being compiled or linked with it, is called a "work that uses the Library". Such a work, in isolation, is not a derivative work of the Library, and therefore falls outside the scope of this License.

However, linking a "work that uses the Library" with the Library creates an executable that is a derivative of the Library (because it contains portions of the Library), rather than a "work that uses the library". The executable is therefore covered by this License. Section 6 states terms for distribution of such executables.

When a "work that uses the Library" uses material from a header file that is part of the Library, the object code for the work may be a derivative work of the Library even though the source code is not. Whether this is true is especially significant if the work can be linked without the Library, or if the work is itself a library. The threshold for this to be true is not precisely defined by law.

If such an object file uses only numerical parameters, data structure layouts and accessors, and small macros and small inline functions (ten lines or less in length), then the use of the object file is unrestricted, regardless of whether it is legally a derivative work. (Executables containing this object code plus portions of the Library will still fall under Section 6.)

Otherwise, if the work is a derivative of the Library, you may distribute the object code for the work under the terms of Section 6. Any executables containing that work also fall under Section 6, whether or not they are linked directly with the Library itself.

6. As an exception to the Sections above, you may also combine or link a "work that uses the Library" with the Library to produce a work containing portions of the Library, and distribute that work under terms of your choice, provided that the terms permit modification of the work for the customer's own use and reverse engineering for debugging such modifications.

You must give prominent notice with each copy of the work that the Library is used in it and that the Library and its use are covered by this License. You must supply a copy of this License. If the work during execution displays copyright notices, you must include the copyright notice for the Library among them, as well as a reference directing the user to the copy of this License. Also, you must do one of these things:

- Accompany the work with the complete corresponding machine-readable source code for the Library including whatever changes were used in the work (which must be distributed under Sections 1 and 2 above); and, if the work is an executable linked with the Library, with the complete machine-readable "work that uses the Library", as object code and/or source code, so that the user can modify the Library and then relink to produce a modified executable containing the modified Library. (It is understood that the user who changes the contents of definitions files in the Library will not necessarily be able to recompile the application to use the modified definitions.)
- Use a suitable shared library mechanism for linking with the Library. A suitable mechanism is one that (1) uses at run time a copy of the library already present on the user's computer system, rather than copying library functions into the executable, and (2) will operate properly with a modified version of the library, if the user installs one, as long as the modified version is interface-compatible with the version that the work was made with.
- Accompany the work with a written offer, valid for at least three years, to give the same user the materials specified in Subsection 6a, above, for a charge no more than the cost of performing this distribution.
- If distribution of the work is made by offering access to copy from a designated place, offer equivalent access to copy the above specified materials from the same place.
- Verify that the user has already received a copy of these materials or that you have already sent this user a copy.

For an executable, the required form of the "work that uses the Library" must include any data and utility programs needed for reproducing the executable from it. However, as a special exception, the materials to be distributed need not include anything that is normally distributed (in either source or binary form) with the major components (compiler, kernel, and so on) of the operating system on which the executable runs, unless that component itself accompanies the executable.

It may happen that this requirement contradicts the license restrictions of other proprietary libraries that do not normally accompany the operating system. Such a contradiction means you cannot use both them and the Library together in an executable that you distribute.

7. You may place library facilities that are a work based on the Library side-by-side in a single library together with other library facilities not covered by this License, and distribute such a combined library, provided that the separate distribution of the work based on the Library and of the other library facilities is otherwise permitted, and provided that you do these two things:

- Accompany the combined library with a copy of the same work based on the Library, uncombined with any other library facilities. This must be distributed under the terms of the Sections above.

- b) Give prominent notice with the combined library of the fact that part of it is a work based on the Library, and explaining where to find the accompanying uncombined form of the same work.
8. You may not copy, modify, sublicense, link with, or distribute the Library except as expressly provided under this License. Any attempt otherwise to copy, modify, sublicense, link with, or distribute the Library is void, and will automatically terminate your rights under this License. However, parties who have received copies, or rights, from you under this License will not have their licenses terminated so long as such parties remain in full compliance.
9. You are not required to accept this License, since you have not signed it. However, nothing else grants you permission to modify or distribute the Library or its derivative works. These actions are prohibited by law if you do not accept this License. Therefore, by modifying or distributing the Library (or any work based on the Library), you indicate your acceptance of this License to do so, and all its terms and conditions for copying, distributing or modifying the Library or works based on it.
10. Each time you redistribute the Library (or any work based on the Library), the recipient automatically receives a license from the original licensor to copy, distribute, link with or modify the Library subject to these terms and conditions. You may not impose any further restrictions on the recipients' exercise of the rights granted herein. You are not responsible for enforcing compliance by third parties with this License.
11. If, as a consequence of a court judgment or allegation of patent infringement or for any other reason (not limited to patent issues), conditions are imposed on you (whether by court order, agreement or otherwise) that contradict the conditions of this License, they do not excuse you from the conditions of this License. If you cannot distribute so as to satisfy simultaneously your obligations under this License and any other pertinent obligations, then as a consequence you may not distribute the Library at all. For example, if a patent license would not permit royalty-free redistribution of the Library by all those who receive copies directly or indirectly through you, then the only way you could satisfy both it and this License would be to refrain entirely from distribution of the Library.

If any portion of this section is held invalid or unenforceable under any particular circumstance, the balance of the section is intended to apply, and the section as a whole is intended to apply in other circumstances.

It is not the purpose of this section to induce you to infringe any patents or other property right claims or to contest validity of any such claims; this section has the sole purpose of protecting the integrity of the free software distribution system which is implemented by public license practices. Many people have made generous contributions to the wide range of software distributed through that system in reliance on consistent application of that system; it is up to the author/donor to decide if he or she is willing to distribute software through any other system and a licensee cannot impose that choice.

This section is intended to make thoroughly clear what is believed to be a consequence of the rest of this License.

12. If the distribution and/or use of the Library is restricted in certain countries either by patents or by copyrighted interfaces, the original copyright holder who places the Library under this License may add an explicit geographical distribution limitation excluding those countries, so that distribution is permitted only in or among countries not thus excluded. In such case, this License incorporates the limitation as if written in the body of this License.
13. The Free Software Foundation may publish revised and/or new versions of the Lesser General Public License from time to time. Such new versions will be similar in spirit to the present version, but may differ in detail to address new problems or concerns.
- Each version is given a distinguishing version number. If the Library specifies a version number of this License which applies to it and "any later version", you have the option of following the terms and conditions either of that version or of any later version published by the Free Software Foundation. If the Library does not specify a license version number, you may choose any version ever published by the Free Software Foundation.
14. If you wish to incorporate parts of the Library into other free programs whose distribution conditions are incompatible with these, write to the author to ask for permission. For software which is copyrighted by the Free Software Foundation, write to the Free Software Foundation; we sometimes make exceptions for this. Our decision will be guided by the two goals of preserving the free status of all derivatives of our free software and of promoting the sharing and reuse of software generally.

NO WARRANTY

15. BECAUSE THE LIBRARY IS LICENSED FREE OF CHARGE, THERE IS NO WARRANTY FOR THE LIBRARY, TO THE EXTENT PERMITTED BY APPLICABLE LAW. EXCEPT WHEN OTHERWISE STATED IN WRITING THE COPYRIGHT HOLDERS AND/OR OTHER PARTIES PROVIDE THE LIBRARY "AS IS" WITHOUT WARRANTY OF ANY KIND, EITHER EXPRESSED OR IMPLIED, INCLUDING, BUT NOT LIMITED TO, THE IMPLIED WARRANTIES OF MERCHANTABILITY AND FITNESS FOR A PARTICULAR PURPOSE. THE ENTIRE RISK AS TO THE QUALITY AND PERFORMANCE OF THE LIBRARY IS WITH YOU. SHOULD THE LIBRARY PROVE DEFECTIVE, YOU ASSUME THE COST OF ALL NECESSARY SERVICING, REPAIR OR CORRECTION.

16. IN NO EVENT UNLESS REQUIRED BY APPLICABLE LAW OR AGREED TO IN WRITING WILL ANY COPYRIGHT HOLDER, OR ANY OTHER PARTY WHO MAY MODIFY AND/OR REDISTRIBUTE THE LIBRARY AS PERMITTED ABOVE, BE LIABLE TO YOU FOR DAMAGES, INCLUDING ANY GENERAL, SPECIAL, INCIDENTAL OR CONSEQUENTIAL DAMAGES ARISING OUT OF THE USE OR INABILITY TO USE THE LIBRARY (INCLUDING BUT NOT LIMITED TO LOSS OF DATA OR DATA BEING RENDERED INACCURATE OR LOSSES SUSTAINED BY YOU OR THIRD PARTIES OR A FAILURE OF THE LIBRARY TO OPERATE WITH ANY OTHER SOFTWARE), EVEN IF SUCH HOLDER OR OTHER PARTY HAS BEEN ADVISED OF THE POSSIBILITY OF SUCH DAMAGES.

END OF TERMS AND CONDITIONS

How to Apply These Terms to Your New Libraries

If you develop a new library, and you want it to be of the greatest possible use to the public, we recommend making it free software that everyone can redistribute and change. You can do so by permitting redistribution under these terms (or, alternatively, under the terms of the ordinary General Public License). To apply these terms, attach the following notices to the library. It is safest to attach them to the start of each source file to most effectively convey the exclusion of warranty; and each file should have at least the "copyright" line and a pointer to where the full notice is found.

```
<one line to give the library's name and a brief idea of what it does.> Copyright (C)
<year> <name of author>
```

This library is free software; you can redistribute it and/or modify it under the terms of the GNU Lesser General Public License as published by the Free Software Foundation; either version 2 of the License, or (at your option) any later version.

This library is distributed in the hope that it will be useful, but WITHOUT ANY WARRANTY; without even the implied warranty of MERCHANTABILITY or FITNESS FOR A PARTICULAR PURPOSE. See the GNU Lesser General Public License for more details.

You should have received a copy of the GNU Lesser General Public License along with this library; if not, write to the Free Software Foundation, Inc., 59 Temple Place, Suite 330, Boston, MA 02111-1307 USA

Also add information on how to contact you by electronic and paper mail.

You should also get your employer (if you work as a programmer) or your school, if any, to sign a "copyright disclaimer" for the library, if necessary. Here is a sample; alter the names:

```
Yoyodyne, Inc., hereby disclaims all copyright interest in the library 'Frob' (a
library for tweaking knobs) written by James Random Hacker.
```

```
<signature of Ty Coon>, 1 April 1990 Ty Coon, President of Vice
```

That's all there is to it!

■ About Fusion

DirectFB Fusion kernel module: introduction and API

by Niels Røest

Copyright (C) 2009 Niels Røest

This documentation is free software; you can redistribute it and/or modify it under the terms of the GNU General Public License as published by the Free Software Foundation; either version 2 of the License, or (at your option) any later version.

This program is distributed in the hope that it will be useful, but WITHOUT ANY WARRANTY; without even the implied warranty of MERCHANTABILITY or FITNESS FOR A PARTICULAR PURPOSE. See the GNU General Public License for more details.

You should have received a copy of the GNU General Public License along with this program; if not, write to the Free Software Foundation, Inc., 59 Temple Place, Suite 330, Boston, MA 02111-1307 USA
For more details see the file COPYING in the source distribution of Linux.

■ About openssl

Copyright (C) 1998-2008 The OpenSSL Project. All rights reserved.

Redistribution and use in source and binary forms, with or without modification, are permitted provided that the following conditions are met:

1. Redistributions of source code must retain the above copyright notice, this list of conditions and the following disclaimer.
2. Redistributions in binary form must reproduce the above copyright notice, this list of conditions and the following disclaimer in the documentation and/or other materials provided with the distribution.
3. All advertising materials mentioning features or use of this software must display the following acknowledgment:
"This product includes software developed by the OpenSSL Project for use in the OpenSSL Toolkit. (<http://www.openssl.org/>)"
4. The names "OpenSSL Toolkit" and "OpenSSL Project" must not be used to endorse or promote products derived from this software without prior written permission. For written permission, please contact openssl-core@openssl.org.
5. Products derived from this software may not be called "OpenSSL" nor may "OpenSSL" appear in their names without prior written permission of the OpenSSL Project.
6. Redistributions of any form whatsoever must retain the following acknowledgment:
"This product includes software developed by the OpenSSL Project for use in the OpenSSL Toolkit (<http://www.openssl.org/>)"

THIS SOFTWARE IS PROVIDED BY THE OpenSSL PROJECT "AS IS" AND ANY EXPRESSED OR IMPLIED WARRANTIES, INCLUDING, BUT NOT LIMITED TO, THE IMPLIED WARRANTIES OF MERCHANTABILITY AND FITNESS FOR A PARTICULAR PURPOSE ARE DISCLAIMED. IN NO EVENT SHALL THE OpenSSL PROJECT OR ITS CONTRIBUTORS BE LIABLE FOR ANY DIRECT, INDIRECT, INCIDENTAL, SPECIAL, EXEMPLARY, OR CONSEQUENTIAL DAMAGES (INCLUDING, BUT NOT LIMITED TO, PROCUREMENT OF SUBSTITUTE GOODS OR SERVICES; LOSS OF USE, DATA, OR PROFITS; OR BUSINESS INTERRUPTION) HOWEVER CAUSED AND ON ANY THEORY OF LIABILITY, WHETHER IN CONTRACT, STRICT LIABILITY, OR TORT (INCLUDING NEGLIGENCE OR OTHERWISE) ARISING IN ANY WAY OUT OF THE USE OF THIS SOFTWARE, EVEN IF ADVISED OF THE POSSIBILITY OF SUCH DAMAGE.

This product includes cryptographic software written by Eric Young (eay@cryptsoft.com). This product includes software written by Tim Hudson (tjh@cryptsoft.com).

Original SSLeay License

Copyright (C) 1995-1998 Eric Young (eay@cryptsoft.com) All rights reserved. This package is an SSL implementation written by Eric Young (eay@cryptsoft.com). The implementation was written so as to conform with Netscapes SSL. This library is free for commercial and non-commercial use as long as the following conditions are adhered to. The following conditions apply to all code found in this distribution, be it the RC4, RSA, lhash, DES, etc., code; not just the SSL code. The SSL documentation included with this distribution is covered by the same copyright terms except that the holder is Tim Hudson (tjh@cryptsoft.com). Copyright remains Eric Young's, and as such any Copyright notices in the code are not to be removed. If this package is used in a product, Eric Young should be given attribution as the author of the parts of the library used. This can be in the form of a textual message at program startup or in documentation (online or textual) provided with the package. Redistribution and use in source and binary forms, with or without modification, are permitted provided that the following conditions are met:

1. Redistributions of source code must retain the copyright notice, this list of conditions and the following disclaimer.
 2. Redistributions in binary form must reproduce the above copyright notice, this list of conditions and the following disclaimer in the documentation and/or other materials provided with the distribution.
 3. All advertising materials mentioning features or use of this software must display the following acknowledgement:
"This product includes cryptographic software written by Eric Young (eay@cryptsoft.com)" The word 'cryptographic' can be left out if the routines from the library being used are not cryptographic related -).
 4. If you include any Windows specific code (or a derivative thereof) from the apps directory (application code) you must include an acknowledgement:
"This product includes software written by Tim Hudson (tjh@cryptsoft.com)"
- THIS SOFTWARE IS PROVIDED BY ERIC YOUNG "AS IS" AND ANY EXPRESS OR IMPLIED WARRANTIES, INCLUDING, BUT NOT LIMITED TO, THE IMPLIED WARRANTIES OF MERCHANTABILITY AND FITNESS FOR A PARTICULAR PURPOSE ARE DISCLAIMED. IN NO EVENT SHALL THE AUTHOR OR CONTRIBUTORS BE LIABLE FOR ANY DIRECT, INDIRECT, INCIDENTAL, SPECIAL, EXEMPLARY, OR CONSEQUENTIAL DAMAGES (INCLUDING, BUT NOT LIMITED TO, PROCUREMENT OF SUBSTITUTE GOODS OR SERVICES; LOSS OF USE, DATA, OR PROFITS; OR BUSINESS INTERRUPTION) HOWEVER CAUSED AND ON ANY THEORY OF LIABILITY, WHETHER IN CONTRACT, STRICT LIABILITY, OR TORT (INCLUDING NEGLIGENCE OR OTHERWISE) ARISING IN ANY WAY OUT OF THE USE OF THIS SOFTWARE, EVEN IF ADVISED OF THE POSSIBILITY OF SUCH DAMAGE.

The licence and distribution terms for any publically available version or derivative of this code cannot be changed. i.e. this code cannot simply be copied and put under another distribution licence [including the GNU Public Licence.]

■ About zlib

Copyright notice:

(C) 1995-2004 Jean-loup Gailly and Mark Adler
This software is provided 'as-is', without any express or implied warranty. In no event will the authors be held liable for any damages arising from the use of this software. Permission is granted to anyone to use this software for any purpose, including commercial applications, and to alter it and redistribute it freely, subject to the following restrictions:

1. The origin of this software must not be misrepresented; you must not claim that you wrote the original software. If you use this software in a product, an acknowledgment in the product documentation would be appreciated but is not required.
2. Altered source versions must be plainly marked as such, and must not be misrepresented as being the original software.
3. This notice may not be removed or altered from any source distribution.

Jean-loup Gailly Mark Adler

jloup@gzip.org madler@alumni.caltech.edu

If you use the zlib library in a product, we would appreciate *not* receiving lengthy legal documents to sign. The sources are provided for free but without warranty of any kind. The library has been entirely written by Jean-loup Gailly and Mark Adler; it does not include third-party code.

If you redistribute modified sources, we would appreciate that you include in the file ChangeLog history information documenting your changes. Please read the FAQ for more information on the distribution of modified source versions.

■ About FreeType

The FreeType Project LICENSE

2006-Jan-27

Copyright 1996-2002, 2006 by
David Turner, Robert Wilhelm, and Werner Lemberg

Introduction

The FreeType Project is distributed in several archive packages; some of them may contain, in addition to the FreeType font engine, various tools and contributions which rely on, or relate to, the FreeType Project.

This license applies to all files found in such packages, and which do not fall under their own explicit license. The license affects thus the FreeType font engine, the test programs, documentation and makefiles, at the very least.

This license was inspired by the BSD, Artistic, and IJG (Independent JPEG Group) licenses, which all encourage inclusion and use of free software in commercial and freeware products alike. As a consequence, its main points are that:

- o We don't promise that this software works. However, we will be interested in any kind of bug reports. ('as is' distribution)
- o You can use this software for whatever you want, in parts or full form, without having to pay us. ('royalty-free' usage)
- o You may not pretend that you wrote this software. If you use it, or only parts of it, in a program, you must acknowledge somewhere in your documentation that you have used the FreeType code. ('credits')

We specifically permit and encourage the inclusion of this software, with or without modifications, in commercial products. We disclaim all warranties covering The FreeType Project and assume no liability related to The FreeType Project. Finally, many people asked us for a preferred form for a credit/disclaimer to use in compliance with this license. We thus encourage you to use the following text:

Portions of this software are copyright (C) <year> The FreeType Project (www.freetype.org). All rights reserved.

Please replace <year> with the value from the FreeType version you actually use.

Legal Terms

0. Definitions

Throughout this license, the terms 'package', 'FreeType Project', and 'FreeType archive' refer to the set of files originally distributed by the authors (David Turner, Robert Wilhelm, and Werner Lemberg) as the 'FreeType Project', be they named as alpha, beta or final release.

'You' refers to the licensee, or person using the project, where 'using' is a generic term including compiling the project's source code as well as linking it to form a 'program' or 'executable'. This program is referred to as 'a program using the FreeType engine'. This license applies to all files distributed in the original FreeType Project, including all source code, binaries and documentation, unless otherwise stated in the file in its original, unmodified form as distributed in the original archive. If you are unsure whether or not a particular file is covered by this license, you must contact us to verify this.

The FreeType Project is copyright (C) 1996-2000 by David Turner, Robert Wilhelm, and Werner Lemberg. All rights reserved except as specified below.

1. No Warranty

THE FREETYPE PROJECT IS PROVIDED 'AS IS' WITHOUT WARRANTY OF ANY KIND, EITHER EXPRESS OR IMPLIED, INCLUDING, BUT NOT LIMITED TO, WARRANTIES OF MERCHANTABILITY AND FITNESS FOR A PARTICULAR PURPOSE. IN NO EVENT WILL ANY OF THE AUTHORS OR COPYRIGHT HOLDERS BE LIABLE FOR ANY DAMAGES CAUSED BY THE USE OR THE INABILITY TO USE, OF THE FREETYPE PROJECT.

2. Redistribution

This license grants a worldwide, royalty-free, perpetual and irrevocable right and license to use, execute, perform, compile, display, copy, create derivative works of, distribute and sublicense the FreeType Project (in both source and object code forms) and derivative works thereof for any purpose; and to authorize others to exercise some or all of the rights granted herein, subject to the following conditions:

- o Redistribution of source code must retain this license file ('FTL.TXT') unaltered; any additions, deletions or changes to the original files must be clearly indicated in accompanying documentation. The copyright notices of the unaltered, original files must be preserved in all copies of source files.
- o Redistribution in binary form must provide a disclaimer that states that the software is based in part of the work of the FreeType Team, in the distribution documentation. We also encourage you to put an URL to the FreeType web page in your documentation, though this isn't mandatory.

These conditions apply to any software derived from or based on the FreeType Project, not just the unmodified files. If you use our work, you must acknowledge us. However, no fee need be paid to us.

3. Advertising

Neither the FreeType authors and contributors nor you shall use the name of the other for commercial, advertising, or promotional purposes without specific prior written permission.

We suggest, but do not require, that you use one or more of the following phrases to refer to this software in your documentation or advertising materials: 'FreeType Project', 'FreeType Engine', 'FreeType library', or 'FreeType Distribution'.

As you have not signed this license, you are not required to accept it. However, as the FreeType Project is copyrighted material, only this license, or another one contracted with the authors, grants you the right to use, distribute, and modify it. Therefore, by using, distributing, or modifying the FreeType Project, you indicate that you understand and accept all the terms of this license.

4. Contacts

There are two mailing lists related to FreeType:

o freetype@nongnu.org

Discusses general use and applications of FreeType, as well as future and wanted additions to the library and distribution. If you are looking for support, start in this list if you haven't found anything to help you in the documentation.

o freetype-devel@nongnu.org

Discusses bugs, as well as engine internals, design issues, specific licenses, porting, etc. Our home page can be found at

<http://www.freetype.org>

■ About Expat

Copyright (C) 1998, 1999, 2000 Thai Open Source Software Center Ltd
and Clark Cooper

Copyright (C) 2001, 2002, 2003, 2004, 2005, 2006 Expat maintainers.

Permission is hereby granted, free of charge, to any person obtaining a copy of this software and associated documentation files (the "Software"), to deal in the Software without restriction, including without limitation the rights to use, copy, modify, merge, publish, distribute, sublicense, and/or sell copies of the Software, and to permit persons to whom the Software is furnished to do so, subject to the following conditions:
The above copyright notice and this permission notice shall be included in all copies or substantial portions of the Software.

THE SOFTWARE IS PROVIDED "AS IS", WITHOUT WARRANTY OF ANY KIND, EXPRESS OR IMPLIED, INCLUDING BUT NOT LIMITED TO THE WARRANTIES OF MERCHANTABILITY, FITNESS FOR A PARTICULAR PURPOSE AND NONINFRINGEMENT. IN NO EVENT SHALL THE AUTHORS OR COPYRIGHT HOLDERS BE LIABLE FOR ANY CLAIM, DAMAGES OR OTHER LIABILITY, WHETHER IN AN ACTION OF CONTRACT, TORT OR OTHERWISE, ARISING FROM, OUT OF OR IN CONNECTION WITH THE SOFTWARE OR THE USE OR OTHER DEALINGS IN THE SOFTWARE.

■ About cURL, libcurl

COPYRIGHT AND PERMISSION NOTICE

Copyright (C) 1996 - 2009, Daniel Stenberg, <daniel@haxx.se>. All rights reserved.

Permission to use, copy, modify, and distribute this software for any purpose with or without fee is hereby granted, provided that the above copyright notice and this permission notice appear in all copies.

THE SOFTWARE IS PROVIDED "AS IS", WITHOUT WARRANTY OF ANY KIND, EXPRESS OR IMPLIED, INCLUDING BUT NOT LIMITED TO THE WARRANTIES OF MERCHANTABILITY, FITNESS FOR A PARTICULAR PURPOSE AND NONINFRINGEMENT OF THIRD PARTY RIGHTS. IN NO EVENT SHALL THE AUTHORS OR COPYRIGHT HOLDERS BE LIABLE FOR ANY CLAIM, DAMAGES OR OTHER LIABILITY, WHETHER IN AN ACTION OF CONTRACT, TORT OR OTHERWISE, ARISING FROM, OUT OF OR IN CONNECTION WITH THE SOFTWARE OR THE USE OR OTHER DEALINGS IN THE SOFTWARE.

Except as contained in this notice, the name of a copyright holder shall not be used in advertising or otherwise to promote the sale, use or other dealings in this Software without prior written authorization of the copyright holder.

■ About Independent JPEG Group's software, libjpeg

In plain English:

1. We don't promise that this software works. (But if you find any bugs, please let us know!)

2. You can use this software for whatever you want. You don't have to pay us.

3. You may not pretend that you wrote this software. If you use it in a program, you must acknowledge somewhere in your documentation that you've used the IJG code.

In legalese:

The authors make NO WARRANTY or representation, either express or implied, with respect to this software, its quality, accuracy, merchantability, or fitness for a particular purpose. This software is provided "AS IS", and you, its user, assume the entire risk as to its quality and accuracy.

This software is copyright (C) 1991-2009, Thomas G. Lane, Guido Vollbeding.

All Rights Reserved except as specified below.

Permission is hereby granted to use, copy, modify, and distribute this software (or portions thereof) for any purpose, without fee, subject to these conditions:

(1) If any part of the source code for this software is distributed, then this README file must be included, with this copyright and no-warranty notice unaltered; and any additions, deletions, or changes to the original files must be clearly indicated in accompanying documentation.

(2) If only executable code is distributed, then the accompanying documentation must state that "this software is based in part on the work of the Independent JPEG Group".

(3) Permission for use of this software is granted only if the user accepts full responsibility for any undesirable consequences; the authors accept NO LIABILITY for damages of any kind.

These conditions apply to any software derived from or based on the IJG code, not just to the unmodified library. If you use our work, you ought to acknowledge us.

Permission is NOT granted for the use of any IJG author's name or company name in advertising or publicity relating to this software or products derived from it. This software may be referred to only as "the Independent JPEG Group's software".

We specifically permit and encourage the use of this software as the basis of commercial products, provided that all warranty or liability claims are assumed by the product vendor.

ansi2knr.c is included in this distribution by permission of L. Peter Deutsch, sole proprietor of its copyright holder, Aladdin Enterprises of Menlo Park, CA. ansi2knr.c is NOT covered by the above copyright and conditions, but instead by the usual distribution terms of the Free Software Foundation; principally, that you must include source code if you redistribute it. (See the file ansi2knr.c for full details.) However, since ansi2knr.c is not needed as part of any program generated from the IJG code, this does not limit you more than the foregoing paragraphs do.

The Unix configuration script "configure" was produced with GNU Autoconf. It is copyright by the Free Software Foundation but is freely distributable. The same holds for its supporting scripts (config.guess, config.sub, lmain.sh). Another support script, install-sh, is copyright by X Consortium but is also freely distributable.

The IJG distribution formerly included code to read and write GIF files. To avoid entanglement with the Unisys LZW patent, GIF reading support has been removed altogether, and the GIF writer has been simplified to produce "uncompressed GIFs". This technique does not use the LZW algorithm; the resulting GIF files are larger than usual, but are readable by all standard GIF decoders.

We are required to state that

"The Graphics Interchange Format(c) is the Copyright property of
CompuServe Incorporated. GIF(sm) is a Service Mark property of
CompuServe Incorporated."

■ About International Components for Unicode

ICU License - ICU 1.8.1 and later

COPYRIGHT AND PERMISSION NOTICE

Copyright (C) 1995-2003 International Business Machines Corporation and others
All rights reserved.

Permission is hereby granted, free of charge, to any person obtaining a copy of this software and associated documentation files (the "Software"), to deal in the Software without restriction, including without limitation the rights to use, copy, modify, merge, publish, distribute, and/or sell copies of the Software, and to permit persons to whom the Software is furnished to do so, provided that the above copyright notice(s) and this permission notice appear in all copies of the Software and that both the above copyright notice(s) and this permission notice appear in supporting documentation.

THE SOFTWARE IS PROVIDED "AS IS", WITHOUT WARRANTY OF ANY KIND, EXPRESS OR IMPLIED, INCLUDING BUT NOT LIMITED TO THE WARRANTIES OF MERCHANTABILITY, FITNESS FOR A PARTICULAR PURPOSE AND NONINFRINGEMENT OF THIRD PARTY RIGHTS. IN NO EVENT SHALL THE COPYRIGHT HOLDER OR HOLDERS INCLUDED IN THIS NOTICE BE LIABLE FOR ANY CLAIM, OR ANY SPECIAL INDIRECT OR CONSEQUENTIAL DAMAGES, OR ANY DAMAGES WHATSOEVER RESULTING FROM LOSS OF USE, DATA OR PROFITS, WHETHER IN AN ACTION OF CONTRACT, NEGLIGENCE OR OTHER TORTIOUS ACTION, ARISING OUT OF OR IN CONNECTION WITH THE USE OR PERFORMANCE OF THIS SOFTWARE.

Except as contained in this notice, the name of a copyright holder shall not be used in advertising or otherwise to promote the sale, use or other dealings in this Software without prior written authorization of the copyright holder.

All trademarks and registered trademarks mentioned herein are the property of their respective owners.

■ About libpng

This copy of the libpng notices is provided for your convenience. In case of any discrepancy between this copy and the notices in the file png.h that is included in the libpng distribution, the latter shall prevail.

COPYRIGHT NOTICE, DISCLAIMER, and LICENSE:

If you modify libpng you may insert additional notices immediately following this sentence. This code is released under the libpng license.

libpng versions 1.2.6, August 15, 2004, through 1.2.47, February 18, 2012, are Copyright (C) 2004, 2006-2009 Glenn Randers-Pehrson, and are distributed according to the same disclaimer and license as libpng-1.2.5 with the following individual added to the list of Contributing Authors

Cosmin Truta

libpng versions 1.0.7, July 1, 2000, through 1.2.5 - October 3, 2002, are Copyright (C) 2000-2002 Glenn Randers-Pehrson, and are distributed according to the same disclaimer and license as libpng-1.0.6 with the following individuals added to the list of Contributing Authors

Simon-Pierre Cadieux

Eric S. Raymond

Gilles Vollant

and with the following additions to the disclaimer:

There is no warranty against interference with your enjoyment of the library or against infringement. There is no warranty that our efforts or the library will fulfill any of your particular purposes or needs. This library is provided with all faults, and the entire risk of satisfactory quality, performance, accuracy, and effort is with the user.

libpng versions 0.97, January 1998, through 1.0.6, March 20, 2000, are Copyright (C) 1998, 1999 Glenn Randers-Pehrson, and are distributed according to the same disclaimer and license as libpng-0.96, with the following individuals added to the list of Contributing Authors:

Tom Lane

Glenn Randers-Pehrson

Willem van Schaik

libpng versions 0.89, June 1996, through 0.96, May 1997, are Copyright (C) 1996, 1997 Andreas Dilger Distributed according to the same disclaimer and license as libpng-0.88, with the following individuals added to the list of Contributing Authors:

John Bowler

Kevin Bracey

Sam Bushell

Magnus Holmgren

Greg Roelofs

Tom Tanner

libpng versions 0.5, May 1995, through 0.88, January 1996, are Copyright (C) 1995, 1996 Guy Eric Schalnat, Group 42, Inc.
For the purposes of this copyright and license, "Contributing Authors" is defined as the following set of individuals:

Andreas Dilger

Dave Martindale

Guy Eric Schalnat

Paul Schmidt

Tim Wegner

The PNG Reference Library is supplied "AS IS". The Contributing Authors and Group 42, Inc. disclaim all warranties, expressed or implied, including, without limitation, the warranties of merchantability and of fitness for any purpose. The Contributing Authors and Group 42, Inc. assume no liability for direct, indirect, incidental, special, exemplary, or consequential damages, which may result from the use of the PNG Reference Library, even if advised of the possibility of such damage. Permission is hereby granted to use, copy, modify, and distribute this source code, or portions hereof, for any purpose, without fee, subject to the following restrictions:

1. The origin of this source code must not be misrepresented.
2. Altered versions must be plainly marked as such and must not be misrepresented as being the original source.
3. This Copyright notice may not be removed or altered from any source or altered source distribution.

The Contributing Authors and Group 42, Inc. specifically permit, without fee, and encourage the use of this source code as a component to supporting the PNG file format in commercial products. If you use this source code in a product, acknowledgment is not required but would be appreciated.

A "png_get_copyright" function is available, for convenient use in "about" boxes and the like:

```
printf("%s",png_get_copyright(NULL));
```

Also, the PNG logo (in PNG format, of course) is supplied in the files "pngbar.png" and "pngbar.jpg (88x31)" and "pngnow.png" (98x31).

Libpng is OSI Certified Open Source Software. OSI Certified Open Source is a certification mark of the Open Source Initiative.

Glenn Randers-Pehrson

glennrp at users.sourceforge.net

February 18, 2012

■ About gSOAP

gSOAP Public License

Version 1.3b

The gSOAP public license is derived from the Mozilla Public License (MPL1.1). The sections that were deleted from the original MPL1.1 text are 1.0.1, 2.1.(c),(d), 2.2.(c),(d), 8.2.(b), 10, and 11. Section 3.8 was added. The modified sections are 2.1.(b), 2.2.(b), 3.2 (simplified), 3.5 (deleted the last sentence), and 3.6 (simplified).

This license applies to the gSOAP software package, with the exception of the wsdl2h source code located in gsoap/wsdl, all code generated by wsdl2h, the UDDI source code gsoap/uddi2, and the Web server sample source code samples/webserver. To use all of the software commercially, a commercial license has to be obtained from www.genivia.com.

1. DEFINITIONS.

1.0.1.

1.1. "Contributor" means each entity that creates or contributes to the creation of Modifications.

1.2. "Contributor Version" means the combination of the Original Code, prior Modifications used by a Contributor, and the Modifications made by that particular Contributor.

1.3. "Covered Code" means the Original Code, or Modifications or the combination of the Original Code, and Modifications, in each case including portions thereof.

1.4. "Electronic Distribution Mechanism" means a mechanism generally accepted in the software development community for the electronic transfer of data.

1.5. "Executable" means Covered Code in any form other than Source Code.

1.6. "Initial Developer" means the individual or entity identified as the Initial Developer in the Source Code notice required by Exhibit A.

1.7. "Larger Work" means a work which combines Covered Code or portions thereof with code not governed by the terms of this License.

1.8. "License" means this document.

1.8.1. "Licensable" means having the right to grant, to the maximum extent possible, whether at the time of the initial grant or subsequently acquired, any and all of the rights conveyed herein.

1.9. "Modifications" means any addition to or deletion from the substance or structure of either the Original Code or any previous Modifications. When Covered Code is released as a series of files, a Modification is:

A. Any addition to or deletion from the contents of a file containing Original Code or previous Modifications. B.

Any new file that contains any part of the Original Code, or previous Modifications.

1.10. "Original Code" means Source Code of computer software code which is described in the Source Code notice required by Exhibit A as Original Code, and which, at the time of its release under this License is not already Covered Code governed by this License.

1.10.1. "Patent Claims" means any patent claim(s), now owned or hereafter acquired, including without limitation, method, process, and apparatus claims, in any patent Licensable by grantor.

<http://www.cs.fsu.edu/~engelen/license.html>

1.11. "Source Code" means the preferred form of the Covered Code for making modifications to it, including all modules it contains, plus any associated interface definition files, scripts used to control compilation and installation of an Executable, or source code differential comparisons against either the Original Code or another well known, available Covered Code of the Contributor's choice. The Source Code can be in a compressed or archival form, provided the appropriate decompression or de-archiving software is widely available for no charge.

1.12. "You" (or "Your") means an individual or a legal entity exercising rights under, and complying with all of the terms of, this License or a future version of this License issued under Section 6.1. For legal entities, "You" includes any entity which controls, is controlled by, or is under common control with You. For purposes of this definition, "control" means (a) the power, direct or indirect, to cause the direction or management of such entity, whether by contract or otherwise, or (b) ownership of more than fifty percent (50%) of the outstanding shares or beneficial ownership of such entity.

2. SOURCE CODE LICENSE.

2.1. The Initial Developer Grant. The Initial Developer hereby grants You a world-wide, royalty-free, non-exclusive license, subject to third party intellectual property claims:

(a)

under intellectual property rights (other than patent or trademark) Licensable by Initial Developer to use, reproduce, modify, display, perform, sublicense and distribute the Original Code (or portions thereof) with or without Modifications, and/or as part of a Larger Work; and

(b)

under patents now or hereafter owned or controlled by Initial Developer, to make, have made, use and sell ("offer to sell and import") the Original Code, Modifications, or portions thereof, but solely to the extent that any such patent is reasonably necessary to enable You to utilize, alone or in combination with other software, the Original Code, Modifications, or any combination or portions thereof.

(c)

(d)

2.2. Contributor Grant.

Subject to third party intellectual property claims, each Contributor hereby grants You a world-wide, royalty-free, non-exclusive license

(a)

under intellectual property rights (other than patent or trademark) Licensable by Contributor, to use, reproduce, modify, display, perform, sublicense and distribute the Modifications created by such Contributor (or portions thereof) either on an unmodified basis, with other Modifications, as Covered Code and/or as part of a Larger Work; and

(b)

under patents now or hereafter owned or controlled by Contributor, to make, have made, use and sell ("offer to sell and import") the Contributor Version (or portions thereof), but solely to the extent that any such patent is reasonably necessary to enable You to utilize, alone or in combination with other software, the Contributor Version (or portions thereof).

(c)

(d)

3. DISTRIBUTION OBLIGATIONS.

3.1. Application of License.

The Modifications which You create or to which You contribute are governed by the terms of this License, including without limitation Section 2.2. The Source Code version of Covered Code may be distributed only under the terms of this License or a future version of this License released under Section 6.1, and You must include a copy of this License with every copy of the Source Code You distribute. You may not offer or impose any terms on any Source Code version that alters or restricts the applicable version of this License or the recipients' rights hereunder. However, You may include an additional document offering the additional rights described in Section 3.5.

3.2. Availability of Source Code.

Any Modification created by You will be provided to the Initial Developer in Source Code form and are subject to the terms of the License.

3.3. Description of Modifications.

You must cause all Covered Code to which You contribute to contain a file documenting the changes You made to create that Covered Code and the date of any change. You must include a prominent statement that the Modification is derived, directly or indirectly, from Original Code provided by the Initial Developer and including the name of the Initial Developer in (a) the Source Code, and (b) in any notice in an Executable version or related documentation in which You describe the origin or ownership of the Covered Code.

3.4. Intellectual Property Matters.

(a) Third Party Claims.

If Contributor has knowledge that a license under a third party's intellectual property rights is required to exercise the rights granted by such Contributor under Sections 2.1 or 2.2, Contributor must include a text file with the Source Code distribution titled "LEGAL" which describes the claim and the party making the claim in sufficient detail that a recipient will know whom to contact. If Contributor obtains such knowledge after the Modification is made available as described in Section 3.2, Contributor shall promptly modify the LEGAL file in all copies Contributor makes available thereafter and shall take other steps (such as notifying appropriate mailing lists or newsgroups) reasonably calculated to inform those who received the Covered Code that new knowledge has been obtained.

(b) Contributor APIs.

If Contributor's Modifications include an application programming interface and Contributor has knowledge of patent licenses which are reasonably necessary to implement that API, Contributor must also include this information in the LEGAL file.

(c) Representations.

Contributor represents that, except as disclosed pursuant to Section 3.4(a) above, Contributor believes that Contributor's Modifications are Contributor's original creation(s) and/or Contributor has sufficient rights to grant the rights conveyed by this License.

3.5. Required Notices.

You must duplicate the notice in Exhibit A in each file of the Source Code. If it is not possible to put such notice in a particular Source Code file due to its structure, then You must include such notice in a location (such as a relevant directory) where a user would be likely to look for such a notice. If You created one or more Modification(s) You may add your name as a Contributor to the notice described in Exhibit A. You must also duplicate this License in any documentation for the Source Code where You describe recipients' rights or ownership rights relating to Covered Code. You may choose to offer, and to charge a fee for, warranty, support, indemnity or liability obligations to one or more recipients of Covered Code. However, You may do so only on Your own behalf, and not on behalf of the Initial Developer or any Contributor.

3.6. Distribution of Executable Versions.

You may distribute Covered Code in Executable form only if the requirements of Section 3.1-3.5 have been met for that Covered Code. You may distribute the Executable version of Covered Code or ownership rights under a license of Your choice, which may contain terms different from this License, provided that You are in compliance with the terms of this License and that the license for the Executable version does not attempt to limit or alter the recipient's rights in the Source Code version from the rights set forth in this License. If You distribute the Executable version under a different license You must make it absolutely clear that any terms which differ from this License are offered by You alone, not by the Initial Developer or any Contributor. If you distribute executable versions containing Covered Code as part of a product, you must reproduce the notice in Exhibit B in the documentation and/or other materials provided with the product.

3.7. Larger Works.

You may create a Larger Work by combining Covered Code with other code not governed by the terms of this License and distribute the Larger Work as a single product. In such a case, You must make sure the requirements of this License are fulfilled for the Covered Code.

3.8. Restrictions.

You may not remove any product identification, copyright, proprietary notices or labels from gSOAP.

4. INABILITY TO COMPLY DUE TO STATUTE OR REGULATION.

If it is impossible for You to comply with any of the terms of this License with respect to some or all of the Covered Code due to statute, judicial order, or regulation then You must: (a) comply with the terms of this License to the maximum extent possible; and (b) describe the limitations and the code they affect. Such description must be included in the LEGAL file described in Section 3.4 and must be included with all distributions of the Source Code. Except to the extent prohibited by statute or regulation, such description must be sufficiently detailed for a recipient of ordinary skill to be able to understand it.

5. APPLICATION OF THIS LICENSE.

This License applies to code to which the Initial Developer has attached the notice in Exhibit A and to related Covered Code.

6. VERSIONS OF THE LICENSE.

6.1. New Versions.

Grantor may publish revised and/or new versions of the License from time to time. Each version will be given a distinguishing version number.

6.2. Effect of New Versions.

Once Covered Code has been published under a particular version of the License, You may always continue to use it under the terms of that version. You may also choose to use such Covered Code under the terms of any subsequent version of the License.

6.3. Derivative Works.

If You create or use a modified version of this License (which you may only do in order to apply it to code which is not already Covered Code governed by this License), You must (a) rename Your license so that the phrase "gSOAP" or any confusingly similar phrase do not appear in your license (except to note that your license differs from this License) and (b) otherwise make it clear that Your version of the license contains terms which differ from the gSOAP Public License. (Filling in the name of the Initial Developer, Original Code or Contributor in the notice described in Exhibit A shall not of themselves be deemed to be modifications of this License.)

7. DISCLAIMER OF WARRANTY.

COVERED CODE IS PROVIDED UNDER THIS LICENSE ON AN "AS IS" BASIS, WITHOUT WARRANTY OF ANY KIND, WHETHER EXPRESS, IMPLIED OR STATUTORY, INCLUDING, WITHOUT LIMITATION, THE IMPLIED WARRANTIES OF MERCHANTABILITY, OF FITNESS FOR A PARTICULAR PURPOSE, NON-INFRINGEMENT OF THIRD PARTY INTELLECTUAL PROPERTY RIGHTS, AND ANY WARRANTY THAT MAY ARISE BY REASON OF TRADE USAGE, CUSTOM, OR COURSE OF DEALING. WITHOUT LIMITING THE FOREGOING, YOU ACKNOWLEDGE THAT THE SOFTWARE IS PROVIDED "AS IS" AND THAT THE AUTHORS DO NOT WARRANT THE SOFTWARE WILL RUN UNINTERRUPTED OR ERROR FREE. LIMITED LIABILITY THE ENTIRE RISK AS TO RESULTS AND PERFORMANCE OF THE SOFTWARE IS ASSUMED BY YOU. UNDER NO CIRCUMSTANCES WILL THE AUTHORS BE LIABLE FOR ANY SPECIAL, INDIRECT, INCIDENTAL, EXEMPLARY OR CONSEQUENTIAL DAMAGES OF ANY KIND OR NATURE WHATSOEVER, WHETHER BASED ON CONTRACT, WARRANTY, TORT (INCLUDING NEGLIGENCE), STRICT LIABILITY OR OTHERWISE, ARISING OUT OF OR IN ANY WAY RELATED TO THE SOFTWARE, EVEN IF THE AUTHORS HAVE BEEN ADVISED ON THE POSSIBILITY OF SUCH DAMAGE OR IF SUCH DAMAGE COULD HAVE BEEN REASONABLY FORESEEN, AND NOTWITHSTANDING ANY FAILURE OF ESSENTIAL PURPOSE OF ANY EXCLUSIVE REMEDY PROVIDED. SUCH LIMITATION ON DAMAGES INCLUDES, BUT IS NOT LIMITED TO, DAMAGES FOR LOSS OF GOODWILL, LOST PROFITS, LOSS OF DATA OR SOFTWARE, WORK STOPPAGE, COMPUTER FAILURE OR MALFUNCTION OR IMPAIRMENT OF OTHER GOODS. IN NO EVENT WILL THE AUTHORS BE LIABLE FOR THE COSTS OF PROCUREMENT OF SUBSTITUTE SOFTWARE OR SERVICES. YOU

ACKNOWLEDGE THAT THIS SOFTWARE IS NOT DESIGNED FOR USE IN ON-LINE EQUIPMENT IN HAZARDOUS ENVIRONMENTS SUCH AS OPERATION OF NUCLEAR FACILITIES, AIRCRAFT NAVIGATION OR CONTROL, OR LIFE-CRITICAL APPLICATIONS. THE AUTHORS EXPRESSLY DISCLAIM ANY LIABILITY RESULTING FROM USE OF THE SOFTWARE IN ANY SUCH ON-LINE EQUIPMENT IN HAZARDOUS ENVIRONMENTS AND ACCEPTS NO LIABILITY IN RESPECT OF ANY ACTIONS OR CLAIMS BASED ON THE USE OF THE SOFTWARE IN ANY SUCH ON-LINE EQUIPMENT IN HAZARDOUS ENVIRONMENTS BY YOU. FOR PURPOSES OF THIS PARAGRAPH, THE TERM "LIFE-CRITICAL APPLICATION" MEANS AN APPLICATION IN WHICH THE FUNCTIONING OR MALFUNCTIONING OF THE SOFTWARE MAY RESULT DIRECTLY OR INDIRECTLY IN PHYSICAL INJURY OR LOSS OF HUMAN LIFE. THIS DISCLAIMER OF WARRANTY CONSTITUTES AN ESSENTIAL PART OF THIS LICENSE. NO USE OF ANY COVERED CODE IS AUTHORIZED HEREUNDER EXCEPT UNDER THIS DISCLAIMER.

8. TERMINATION.

8.1.

This License and the rights granted hereunder will terminate automatically if You fail to comply with terms herein and fail to cure such breach within 30 days of becoming aware of the breach. All sublicenses to the Covered Code which are properly granted shall survive any termination of this License. Provisions which, by their nature, must remain in effect beyond the termination of this License shall survive.

8.2.

8.3.

If You assert a patent infringement claim against Participant alleging that such Participant's Contributor Version directly or indirectly infringes any patent where such claim is resolved (such as by license or settlement) prior to the initiation of patent infringement litigation, then the reasonable value of the licenses granted by such Participant under Sections 2.1 or 2.2 shall be taken into account in determining the amount or value of any payment or license.

8.4.

In the event of termination under Sections 8.1 or 8.2 above, all end user license agreements (excluding distributors and resellers) which have been validly granted by You or any distributor hereunder prior to termination shall survive termination.

9. LIMITATION OF LIABILITY.

UNDER NO CIRCUMSTANCES AND UNDER NO LEGAL THEORY, WHETHER TORT (INCLUDING NEGLIGENCE), CONTRACT, OR OTHERWISE, SHALL YOU, THE INITIAL DEVELOPER, ANY OTHER CONTRIBUTOR, OR ANY DISTRIBUTOR OF COVERED CODE, OR ANY SUPPLIER OF ANY OF SUCH PARTIES, BE LIABLE TO ANY PERSON FOR ANY INDIRECT, SPECIAL, INCIDENTAL, OR CONSEQUENTIAL DAMAGES OF ANY CHARACTER INCLUDING, WITHOUT LIMITATION, DAMAGES FOR LOSS OF GOODWILL, WORK STOPPAGE, COMPUTER FAILURE OR MALFUNCTION, OR ANY AND ALL OTHER COMMERCIAL DAMAGES OR LOSSES, EVEN IF SUCH PARTY SHALL HAVE BEEN INFORMED OF THE POSSIBILITY OF SUCH DAMAGES. THIS LIMITATION OF LIABILITY SHALL NOT APPLY TO LIABILITY FOR DEATH OR PERSONAL INJURY RESULTING FROM SUCH PARTY'S NEGLIGENCE TO THE EXTENT APPLICABLE LAW PROHIBITS SUCH LIMITATION. SOME JURISDICTIONS DO NOT ALLOW THE EXCLUSION OR LIMITATION OF INCIDENTAL OR CONSEQUENTIAL DAMAGES, SO THIS EXCLUSION AND LIMITATION MAY NOT APPLY TO YOU.

10. U.S. GOVERNMENT END USERS.

11. MISCELLANEOUS.

12. RESPONSIBILITY FOR CLAIMS.

As between Initial Developer and the Contributors, each party is responsible for claims and damages arising, directly or indirectly, out of its utilization of rights under this License and You agree to work with Initial Developer and Contributors to distribute such responsibility on an equitable basis. Nothing herein is intended or shall be deemed to constitute any admission of liability.

EXHIBIT A.

"The contents of this file are subject to the gSOAP Public License Version 1.3 (the "License"); you may not use this file except in compliance with the License. You may obtain a copy of the License at <http://www.cs.fsu.edu/~engelen/soaplicense.html>

Software distributed under the License is distributed on an "AS IS" basis, WITHOUT WARRANTY OF ANY KIND, either express or implied. See the License for the specific language governing rights and limitations under the License.

The Original Code of the gSOAP Software is: stdsoap.h, stdsoap2.h, stdsoap.c, stdsoap2.c, stdsoap.cpp, stdsoap2.cpp, soapcpp2.h, soapcpp2.c, soapcpp2_lex.l, soapcpp2_yacc.y, error2.h, error2.c, symbol2.c, init2.c, soapdoc2.html, and soapdoc2.pdf, httpget.h, httpget.c, stl.h, stldeque.h, stllist.h, stlvector.h, stlset.h.

The Initial Developer of the Original Code is Robert A. van Engelen. Portions created by Robert A. van Engelen are Copyright (C) 2001-2004 Robert A. van Engelen, Genivia inc. All Rights Reserved. Contributor(s):

_____,"

[Note: The text of this Exhibit A may differ slightly from the text of the notices in the Source Code files of the Original code. You should use the text of this Exhibit A rather than the text found in the Original Code Source Code for Your Modifications.]

EXHIBIT B.

"Part of the software embedded in this product is gSOAP software.

Portions created by gSOAP are Copyright (C) 2001-2009 Robert A. van Engelen, Genivia inc. All Rights Reserved. THE SOFTWARE IN THIS PRODUCT WAS IN PART PROVIDED BY GENIVIA INC AND ANY EXPRESS OR IMPLIED WARRANTIES, INCLUDING, BUT NOT LIMITED TO, THE IMPLIED WARRANTIES OF MERCHANTABILITY AND FITNESS FOR A PARTICULAR PURPOSE ARE DISCLAIMED. IN NO EVENT SHALL THE AUTHOR BE LIABLE FOR ANY DIRECT, INDIRECT, INCIDENTAL, SPECIAL, EXEMPLARY, OR CONSEQUENTIAL DAMAGES (INCLUDING, BUT NOT LIMITED TO, PROCUREMENT OF SUBSTITUTE GOODS OR SERVICES; LOSS OF USE, DATA, OR PROFITS; OR BUSINESS INTERRUPTION) HOWEVER CAUSED AND ON ANY THEORY OF LIABILITY, WHETHER IN CONTRACT, STRICT LIABILITY, OR TORT (INCLUDING NEGLIGENCE OR OTHERWISE) ARISING IN ANY WAY OUT OF THE USE OF THIS SOFTWARE, EVEN IF ADVISED OF THE POSSIBILITY OF SUCH DAMAGE.”
<http://www.cs.fsu.edu/~engelen/license.html>

■ About gcc libgcc, gcc libstdc++

GNU GENERAL PUBLIC LICENSE

Version 3, 29 June 2007

Copyright (C) 2007 Free Software Foundation, Inc. <<http://fsf.org/>>

Everyone is permitted to copy and distribute verbatim copies of this license document, but changing it is not allowed.

Preamble

The GNU General Public License is a free, copyleft license for software and other kinds of works.

The licenses for most software and other practical works are designed to take away your freedom to share and change the works. By contrast, the GNU General Public License is intended to guarantee your freedom to share and change all versions of a program—to make sure it remains free software for all its users. We, the Free Software Foundation, use the GNU General Public License for most of our software; it applies also to any other work released this way by its authors. You can apply it to your programs, too.

When we speak of free software, we are referring to freedom, not price. Our General Public Licenses are designed to make sure that you have the freedom to distribute copies of free software (and charge for them if you wish), that you receive source code or can get it if you want it, that you can change the software or use pieces of it in new free programs, and that you know you can do these things.

To protect your rights, we need to prevent others from denying you these rights or asking you to surrender the rights. Therefore, you have certain responsibilities if you distribute copies of the software, or if you modify it: responsibilities to respect the freedom of others.

For example, if you distribute copies of such a program, whether gratis or for a fee, you must pass on to the recipients the same freedoms that you received. You must make sure that they, too, receive or can get the source code. And you must show them these terms so they know their rights.

Developers that use the GNU GPL protect your rights with two steps:

(1) assert copyright on the software, and (2) offer you this License giving you legal permission to copy, distribute and/or modify it.

For the developers' and authors' protection, the GPL clearly explains that there is no warranty for this free software. For both users' and authors' sake, the GPL requires that modified versions be marked as changed, so that their problems will not be attributed erroneously to authors of previous versions.

Some devices are designed to deny users access to install or run modified versions of the software inside them, although the manufacturer can do so. This is fundamentally incompatible with the aim of protecting users' freedom to change the software. The systematic pattern of such abuse occurs in the area of products for individuals to use, which is precisely where it is most unacceptable. Therefore, we have designed this version of the GPL to prohibit the practice for those products. If such problems arise substantially in other domains, we stand ready to extend this provision to those domains in future versions of the GPL, as needed to protect the freedom of users.

Finally, every program is threatened constantly by software patents. States should not allow patents to restrict development and use of software on general-purpose computers, but in those that do, we wish to avoid the special danger that patents applied to a free program could make it effectively proprietary. To prevent this, the GPL assures that patents cannot be used to render the program non-free.

The precise terms and conditions for copying, distribution and modification follow.

TERMS AND CONDITIONS

0. Definitions.

“This License” refers to version 3 of the GNU General Public License.

“Copyright” also means copyright-like laws that apply to other kinds of works, such as semiconductor masks.

“The Program” refers to any copyrightable work licensed under this License. Each licensee is addressed as “you”. “Licensees” and “recipients” may be individuals or organizations.

To “modify” a work means to copy from or adapt all or part of the work in a fashion requiring copyright permission, other than the making of an exact copy. The resulting work is called a “modified version” of the earlier work or a work “based on” the earlier work.

A “covered work” means either the unmodified Program or a work based on the Program.

To “propagate” a work means to do anything with it that, without permission, would make you directly or secondarily liable for infringement under applicable copyright law, except executing it on a computer or modifying a private copy. Propagation includes copying, distribution (with or without modification), making available to the public, and in some countries other activities as well.

To “convey” a work means any kind of propagation that enables other parties to make or receive copies. Mere interaction with a user through a computer network, with no transfer of a copy, is not conveying.

An interactive user interface displays “Appropriate Legal Notices” to the extent that it includes a convenient and prominently visible feature that (1) displays an appropriate copyright notice, and (2) tells the user that there is no warranty for the work (except to the extent that warranties are provided), that licensees may convey the work under this License, and how to view a copy of this License. If the interface presents a list of user commands or options, such as a menu, a prominent item in the list meets this criterion.

1. Source Code.

The “source code” for a work means the preferred form of the work for making modifications to it. “Object code” means any non-source form of a work.

A “Standard Interface” means an interface that either is an official standard defined by a recognized standards body, or, in the case of interfaces specified for a particular programming language, one that is widely used among developers working in that language.

The “System Libraries” of an executable work include anything, other than the work as a whole, that (a) is included in the normal form of packaging a Major Component, but which is not part of that Major Component, and (b) serves only to enable use of the work with that Major Component, or to implement a Standard Interface for which an implementation is available to the public in source code form. A “Major Component”, in this context, means a major essential component (kernel, window system, and so on) of the specific operating system (if any) on which the executable work runs, or a compiler used to produce the work, or an object code interpreter used to run it.

The “Corresponding Source” for a work in object code form means all the source code needed to generate, install, and (for an executable work) run the object code and to modify the work, including scripts to control those activities. However, it does not include the work's System Libraries, or general-purpose tools or generally available free programs which are used unmodified in performing those activities but which are not part of the work. For example, Corresponding Source includes interface definition files associated with source files for the work, and the source code for shared libraries and dynamically linked subprograms that the work is specifically designed to require, such as by intimate data communication or control flow between those subprograms and other parts of the work.

The Corresponding Source need not include anything that users can regenerate automatically from other parts of the Corresponding Source.

The Corresponding Source for a work in source code form is that same work.

2. Basic Permissions.

All rights granted under this License are granted for the term of copyright on the Program, and are irrevocable provided the stated conditions are met. This License explicitly affirms your unlimited permission to run the unmodified Program. The output from running a covered work is covered by this License only if the output, given its content, constitutes a covered work. This License acknowledges your rights of fair use or other equivalent, as provided by copyright law.

You may make, run and propagate covered works that you do not convey, without conditions so long as your license otherwise remains in force. You may convey covered works to others for the sole purpose of having them make modifications exclusively for you, or provide you with facilities for running those works, provided that you comply with the terms of this License in conveying all material for which you do not control copyright. Those thus making or running the covered works for you must do so exclusively on your behalf, under your direction and control, on terms that prohibit them from making any copies of your copyrighted material outside their relationship with you.

Conveying under any other circumstances is permitted solely under the conditions stated below. Sublicensing is not allowed; section 10 makes it unnecessary.

3. Protecting Users' Legal Rights From Anti-Circumvention Law.

No covered work shall be deemed part of an effective technological measure under any applicable law fulfilling obligations under article 11 of the WIPO copyright treaty adopted on 20 December 1996, or similar laws prohibiting or restricting circumvention of such measures.

When you convey a covered work, you waive any legal power to forbid circumvention of technological measures to the extent such circumvention is effected by exercising rights under this License with respect to the covered work, and you disclaim any intention to limit operation or modification of the work as a means of enforcing, against the work's users, your or third parties' legal rights to forbid circumvention of technological measures.

4. Conveying Verbatim Copies.

You may convey verbatim copies of the Program's source code as you receive it, in any medium, provided that you conspicuously and appropriately publish on each copy an appropriate copyright notice; keep intact all notices stating that this License and any non-permissive terms added in accord with section 7 apply to the code; keep intact all notices of the absence of any warranty; and give all recipients a copy of this License along with the Program.

You may charge any price or no price for each copy that you convey, and you may offer support or warranty protection for a fee.

5. Conveying Modified Source Versions.

You may convey a work based on the Program, or the modifications to produce it from the Program, in the form of source code under the terms of section 4, provided that you also meet all of these conditions:

a) The work must carry prominent notices stating that you modified it, and giving a relevant date.

b) The work must carry prominent notices stating that it is released under this License and any conditions added under section

7. This requirement modifies the requirement in section 4 to "keep intact all notices".

c) You must license the entire work, as a whole, under this License to anyone who comes into possession of a copy. This License will therefore apply, along with any applicable section 7 additional terms, to the whole of the work, and all its parts, regardless of how they are packaged. This License gives no permission to license the work in any other way, but it does not invalidate such permission if you have separately received it.

d) If the work has interactive user interfaces, each must display Appropriate Legal Notices; however, if the Program has interactive interfaces that do not display Appropriate Legal Notices, your work need not make them do so.

A compilation of a covered work with other separate and independent works, which are not by their nature extensions of the covered work, and which are not combined with it such as to form a larger program, in or on a volume of a storage or distribution medium, is called an "aggregate" if the compilation and its resulting copyright are not used to limit the access or legal rights of the compilation's users beyond what the individual works permit. Inclusion of a covered work in an aggregate does not cause this License to apply to the other parts of the aggregate.

6. Conveying Non-Source Forms.

You may convey a covered work in object code form under the terms of sections 4 and 5, provided that you also convey the machine-readable Corresponding Source under the terms of this License, in one of these ways:

a) Convey the object code in, or embodied in, a physical product (including a physical distribution medium), accompanied by the Corresponding Source fixed on a durable physical medium customarily used for software interchange.

b) Convey the object code in, or embodied in, a physical product (including a physical distribution medium), accompanied by a written offer, valid for at least three years and valid for as long as you offer spare parts or customer support for that product model, to give anyone who possesses the object code either (1) a copy of the Corresponding Source for all the software in the product that is covered by this License, on a durable physical medium customarily used for software interchange, for a price no more than your reasonable cost of physically performing this conveying of source, or (2) access to copy the Corresponding Source from a network server at no charge.

c) Convey individual copies of the object code with a copy of the written offer to provide the Corresponding Source. This alternative is allowed only occasionally and noncommercially, and only if you received the object code with such an offer, in accord with subsection 6b.

d) Convey the object code by offering access from a designated place (gratis or for a charge), and offer equivalent access to the Corresponding Source in the same way through the same place at no further charge. You need not require recipients to copy the Corresponding Source along with the object code. If the place to copy the object code is a network server, the Corresponding Source may be on a different server (operated by you or a third party) that supports equivalent copying facilities, provided you maintain clear directions next to the object code saying where to find the Corresponding Source. Regardless of what server hosts the Corresponding Source, you remain obligated to ensure that it is available for as long as needed to satisfy these requirements.

e) Convey the object code using peer-to-peer transmission, provided you inform other peers where the object code and Corresponding Source of the work are being offered to the general public at no charge under subsection 6d.

A separable portion of the object code, whose source code is excluded from the Corresponding Source as a System Library, need not be included in conveying the object code work.

A "User Product" is either (1) a "consumer product", which means any tangible personal property which is normally used for personal, family, or household purposes, or (2) anything designed or sold for incorporation into a dwelling. In determining whether a product is a consumer product, doubtful cases shall be resolved in favor of coverage. For a particular product received by a particular user, "normally used" refers to a typical or common use of that class of product, regardless of the status of the particular user or of the way in which the particular user actually uses, or expects or is expected to use, the product. A product is a consumer product regardless of whether the product has substantial commercial, industrial or non-consumer uses, unless such uses represent the only significant mode of use of the product.

"Installation Information" for a User Product means any methods, procedures, authorization keys, or other information required to install and execute modified versions of a covered work in that User Product from a modified version of its Corresponding Source. The information must suffice to ensure that the continued functioning of the modified object code is in no case prevented or interfered with solely because modification has been made.

If you convey an object code work under this section in, or with, or specifically for use in, a User Product, and the conveying occurs as part of a transaction in which the right of possession and use of the User Product is transferred to the recipient in perpetuity or for a fixed term (regardless of how the transaction is characterized), the Corresponding Source conveyed under this section must be accompanied by the Installation Information. But this requirement does not apply if neither you nor any third party retains the ability to install modified object code on the User Product (for example, the work has been installed in ROM).

The requirement to provide Installation Information does not include a requirement to continue to provide support service, warranty, or updates for a work that has been modified or installed by the recipient, or for the User Product in which it has been modified or installed. Access to a network may be denied when the modification itself materially and adversely affects the operation of the network or violates the rules and protocols for communication across the network.

Corresponding Source conveyed, and Installation Information provided, in accord with this section must be in a format that is publicly documented (and with an implementation available to the public in source code form), and must require no special password or key for unpacking, reading or copying.

7. Additional Terms.

"Additional permissions" are terms that supplement the terms of this License by making exceptions from one or more of its conditions. Additional permissions that are applicable to the entire Program shall be treated as though they were included in this License, to the extent that they are valid under applicable law. If additional permissions apply only to part of the Program, that part may be used separately under those permissions, but the entire Program remains governed by this License without regard to the additional permissions.

When you convey a copy of a covered work, you may at your option remove any additional permissions from that copy, or from any part of it. (Additional permissions may be written to require their own removal in certain cases when you modify the work.) You may place additional permissions on material, added by you to a covered work, for which you have or can give appropriate copyright permission.

Notwithstanding any other provision of this License, for material you add to a covered work, you may (if authorized by the copyright holders of that material) supplement the terms of this License with terms:

a) Disclaiming warranty or limiting liability differently from the terms of sections 15 and 16 of this License; or

b) Requiring preservation of specified reasonable legal notices or author attributions in that material or in the Appropriate Legal Notices displayed by works containing it; or

c) Prohibiting misrepresentation of the origin of that material, or requiring that modified versions of such material be marked in reasonable ways as different from the original version; or

d) Limiting the use for publicity purposes of names of licensors or authors of the material; or

e) Declining to grant rights under trademark law for use of some trade names, trademarks, or service marks; or

f) Requiring indemnification of licensors and authors of that material by anyone who conveys the material (or modified versions of it) with contractual assumptions of liability to the recipient, for any liability that these contractual assumptions directly impose on those licensors and authors.

All other non-permissive additional terms are considered "further restrictions" within the meaning of section 10. If the Program as you received it, or any part of it, contains a notice stating that it is governed by this License along with a term that is a further restriction, you may remove that term. If a license document contains a further restriction but permits relicensing or conveying under this License, you may add to a covered work material governed by the terms of that license document, provided that the further restriction does not survive such relicensing or conveying.

If you add terms to a covered work in accord with this section, you must place, in the relevant source files, a statement of the additional terms that apply to those files, or a notice indicating where to find the applicable terms.

Additional terms, permissive or non-permissive, may be stated in the form of a separately written license, or stated as exceptions; the above requirements apply either way.

8. Termination.

You may not propagate or modify a covered work except as expressly provided under this License. Any attempt otherwise to propagate or modify it is void, and will automatically terminate your rights under this License (including any patent licenses granted under the third paragraph of section 11).

However, if you cease all violation of this License, then your license from a particular copyright holder is reinstated (a) provisionally, unless and until the copyright holder explicitly and finally terminates your license, and (b) permanently, if the copyright holder fails to notify you of the violation by some reasonable means prior to 60 days after the cessation.

Moreover, your license from a particular copyright holder is reinstated permanently if the copyright holder notifies you of the violation by some reasonable means, this is the first time you have received notice of violation of this License (for any work) from that copyright holder, and you cure the violation prior to 30 days after your receipt of the notice.

Termination of your rights under this section does not terminate the licenses of parties who have received copies or rights from you under this License. If your rights have been terminated and not permanently reinstated, you do not qualify to receive new licenses for the same material under section 10.

9. Acceptance Not Required for Having Copies.

You are not required to accept this License in order to receive or run a copy of the Program. Ancillary propagation of a covered work occurring solely as a consequence of using peer-to-peer transmission to receive a copy likewise does not require acceptance. However, nothing other than this License grants you permission to propagate or modify any covered work. These actions infringe copyright if you do not accept this License. Therefore, by modifying or propagating a covered work, you indicate your acceptance of this License to do so.

10. Automatic Licensing of Downstream Recipients.

Each time you convey a covered work, the recipient automatically receives a license from the original licensors, to run, modify and propagate that work, subject to this License. You are not responsible for enforcing compliance by third parties with this License.

An “entity transaction” is a transaction transferring control of an organization, or substantially all assets of one, or subdividing an organization, or merging organizations. If propagation of a covered work results from an entity transaction, each party to that transaction who receives a copy of the work also receives whatever licenses to that work the party’s predecessor in interest had or could give under the previous paragraph, plus a right to possession of the Corresponding Source of the work from the predecessor in interest, if the predecessor has it or can get it with reasonable efforts.

You may not impose any further restrictions on the exercise of the rights granted or affirmed under this License. For example, you may not impose a license fee, royalty, or other charge for exercise of rights granted under this License, and you may not initiate litigation (including a cross-claim or counterclaim in a lawsuit) alleging that any patent claim is infringed by making, using, selling, offering for sale, or importing the Program or any portion of it.

11. Patents.

A “contributor” is a copyright holder who authorizes use under this License of the Program or a work on which the Program is based. The work thus licensed is called the contributor’s “contributor version”.

A contributor’s “essential patent claims” are all patent claims owned or controlled by the contributor, whether already acquired or hereafter acquired, that would be infringed by some manner, permitted by this License, of making, using, or selling its contributor version, but do not include claims that would be infringed only as a consequence of further modification of the contributor version. For purposes of this definition, “control” includes the right to grant patent sublicenses in a manner consistent with the requirements of this License.

Each contributor grants you a non-exclusive, worldwide, royalty-free patent license under the contributor’s essential patent claims, to make, use, sell, offer for sale, import and otherwise run, modify and propagate the contents of its contributor version.

In the following three paragraphs, a “patent license” is any express agreement or commitment, however denominated, not to enforce a patent (such as an express permission to practice a patent or covenant not to sue for patent infringement). To “grant” such a patent license to a party means to make such an agreement or commitment not to enforce a patent against the party.

If you convey a covered work, knowingly relying on a patent license, and the Corresponding Source of the work is not available for anyone to copy, free of charge and under the terms of this License, through a publicly available network server or other readily accessible means, then you must either (1) cause the Corresponding Source to be so available, or (2) arrange to deprive yourself of the benefit of the patent license for this particular work, or (3) arrange, in a manner consistent with the requirements of this License, to extend the patent license to downstream recipients. “Knowingly relying” means you have actual knowledge that, but for the patent license, your conveying the covered work in a country, or your recipient’s use of the covered work in a country, would infringe one or more identifiable patents in that country that you have reason to believe are valid.

If, pursuant to or in connection with a single transaction or arrangement, you convey, or propagate by procuring conveyance of, a covered work, and grant a patent license to some of the parties receiving the covered work authorizing them to use, propagate, modify or convey a specific copy of the covered work, then the patent license you grant is automatically extended to all recipients of the covered work and works based on it.

A patent license is “discriminatory” if it does not include within the scope of its coverage, prohibits the exercise of, or is conditioned on the non-exercise of one or more of the rights that are specifically granted under this License. You may not convey a covered work if you are a party to an arrangement with a third party that is in the business of distributing software, under which you make payment to the third party based on the extent of your activity of conveying the work, and under which the third party grants, to any of the parties who would receive the covered work from you, a discriminatory patent license (a) in connection with copies of the covered work conveyed by you (or copies made from those copies), or (b) primarily for and in connection with specific products or compilations that contain the covered work, unless you entered into that arrangement, or that patent license was granted, prior to 28 March 2007.

Nothing in this License shall be construed as excluding or limiting any implied license or other defenses to infringement that may otherwise be available to you under applicable patent law.

12. No Surrender of Others’ Freedom.

If conditions are imposed on you (whether by court order, agreement or otherwise) that contradict the conditions of this License, they do not excuse you from the conditions of this License. If you cannot convey a covered work so as to satisfy simultaneously your obligations under this License and any other pertinent obligations, then as a consequence you may not convey it at all. For example, if you agree to terms that obligate you to collect a royalty for further conveying from those to whom you convey the Program, the only way you could satisfy both those terms and this License would be to refrain entirely from conveying the Program.

13. Use with the GNU Affero General Public License.

Notwithstanding any other provision of this License, you have permission to link or combine any covered work with a work licensed under version 3 of the GNU Affero General Public License into a single combined work, and to convey the resulting work. The terms of this License will continue to apply to the part which is the covered work, but the special requirements of the GNU Affero General Public License, section 13, concerning interaction through a network will apply to the combination as such.

14. Revised Versions of this License.

The Free Software Foundation may publish revised and/or new versions of the GNU General Public License from time to time. Such new versions will be similar in spirit to the present version, but may differ in detail to address new problems or concerns.

Each version is given a distinguishing version number. If the Program specifies that a certain numbered version of the GNU General Public License “or any later version” applies to it, you have the option of following the terms and conditions either of that numbered version or of any later version published by the Free Software Foundation. If the Program does not specify a version number of the GNU General Public License, you may choose any version ever published by the Free Software Foundation.

If the Program specifies that a proxy can decide which future versions of the GNU General Public License can be used, that proxy’s public statement of acceptance of a version permanently authorizes you to choose that version for the Program.

Later license versions may give you additional or different permissions. However, no additional obligations are imposed on any author or copyright holder as a result of your choosing to follow a later version.

15. Disclaimer of Warranty.

THERE IS NO WARRANTY FOR THE PROGRAM, TO THE EXTENT PERMITTED BY APPLICABLE LAW. EXCEPT WHEN OTHERWISE STATED IN WRITING THE COPYRIGHT HOLDERS AND/OR OTHER PARTIES PROVIDE THE PROGRAM “AS IS” WITHOUT WARRANTY OF ANY KIND, EITHER EXPRESSED OR IMPLIED, INCLUDING, BUT NOT LIMITED TO, THE IMPLIED WARRANTIES OF MERCHANTABILITY AND FITNESS FOR A PARTICULAR PURPOSE. THE ENTIRE RISK AS TO THE QUALITY AND PERFORMANCE OF THE PROGRAM IS WITH YOU. SHOULD THE PROGRAM PROVE DEFECTIVE, YOU ASSUME THE COST OF ALL NECESSARY SERVICING, REPAIR OR CORRECTION.

16. Limitation of Liability.

IN NO EVENT UNLESS REQUIRED BY APPLICABLE LAW OR AGREED TO IN WRITING WILL ANY COPYRIGHT HOLDER, OR ANY OTHER PARTY WHO MODIFIES AND/OR CONVEYS THE PROGRAM AS PERMITTED ABOVE, BE LIABLE TO YOU FOR DAMAGES, INCLUDING ANY GENERAL, SPECIAL, INCIDENTAL OR CONSEQUENTIAL DAMAGES ARISING OUT OF THE USE OR INABILITY TO USE THE PROGRAM (INCLUDING BUT NOT LIMITED TO LOSS OF DATA OR DATA BEING RENDERED INACCURATE OR LOSSES SUSTAINED BY YOU OR THIRD PARTIES OR A FAILURE OF THE PROGRAM TO OPERATE WITH ANY OTHER PROGRAMS), EVEN IF SUCH HOLDER OR OTHER PARTY HAS BEEN ADVISED OF THE POSSIBILITY OF SUCH DAMAGES.

17. Interpretation of Sections 15 and 16.

If the disclaimer of warranty and limitation of liability provided above cannot be given legal effect according to their terms, reviewing courts shall apply local law that most closely approximates an absolute waiver of all civil liability in connection with the Program, unless a warranty or assumption of liability accompanies a copy of the Program in return for a fee.

END OF TERMS AND CONDITIONS

How to Apply These Terms to Your New Programs

If you develop a new program, and you want it to be of the greatest possible use to the public, the best way to achieve this is to make it free software which everyone can redistribute and change under these terms.

To do so, attach the following notices to the program. It is safest to attach them to the start of each source file to most effectively state the exclusion of warranty; and each file should have at least the "copyright" line and a pointer to where the full notice is found.

```
<one line to give the program's name and a brief idea of what it does.>
Copyright (C) <year> <name of author>
```

This program is free software; you can redistribute it and/or modify it under the terms of the GNU General Public License as published by the Free Software Foundation, either version 3 of the License, or (at your option) any later version.

This program is distributed in the hope that it will be useful, but WITHOUT ANY WARRANTY; without even the implied warranty of MERCHANTABILITY or FITNESS FOR A PARTICULAR PURPOSE. See the GNU General Public License for more details.

You should have received a copy of the GNU General Public License along with this program. If not, see <<http://www.gnu.org/licenses/>>.

Also add information on how to contact you by electronic and paper mail.

If the program does terminal interaction, make it output a short notice like this when it starts in an interactive mode:

```
<program> Copyright (C) <year> <name of author>
This program comes with ABSOLUTELY NO WARRANTY; for details type `show w'.
This is free software, and you are welcome to redistribute it under certain conditions;
type `show c' for details.
```

The hypothetical commands `show w' and `show c' should show the appropriate parts of the General Public License. Of course, your program's commands might be different; for a GUI interface, you would use an "about box".

You should also get your employer (if you work as a programmer) or school, if any, to sign a "copyright disclaimer" for the program, if necessary. For more information on this, and how to apply and follow the GNU GPL, see <<http://www.gnu.org/licenses/>>.

The GNU General Public License does not permit incorporating your program into proprietary programs. If your program is a subroutine library, you may consider it more useful to permit linking proprietary applications with the library. If this is what you want to do, use the GNU Lesser General Public License instead of this License. But first, please read <<http://www.gnu.org/philosophy/why-not-lgpl.html>>.

GCC RUNTIME LIBRARY EXCEPTION

Version 3.1, 31 March 2009
Copyright © 2009 Free Software Foundation, Inc. <<http://fsf.org/>>

Everyone is permitted to copy and distribute verbatim copies of this license document, but changing it is not allowed.

This GCC Runtime Library Exception ("Exception") is an additional permission under section 7 of the GNU General Public License, version 3 ("GPLv3"). It applies to a given file (the "Runtime Library") that bears a notice placed by the copyright holder of the file stating that the file is governed by GPLv3 along with this Exception.

When you use GCC to compile a program, GCC may combine portions of certain GCC header files and runtime libraries with the compiled program. The purpose of this Exception is to allow compilation of non-GPL (including proprietary) programs to use, in this way, the header files and runtime libraries covered by this Exception.

0. Definitions.

A file is an "Independent Module" if it either requires the Runtime Library for execution after a Compilation Process, or makes use of an interface provided by the Runtime Library, but is not otherwise based on the Runtime Library.

"GCC" means a version of the GNU Compiler Collection, with or without modifications, governed by version 3 (or a specified later version) of the GNU General Public License (GPL) with the option of using any subsequent versions published by the FSF.

"GPL-compatible Software" is software whose conditions of propagation, modification and use would permit combination with GCC in accord with the license of GCC.

"Target Code" refers to output from any compiler for a real or virtual target processor architecture, in executable form or suitable for input to an assembler, loader, linker and/or execution phase. Notwithstanding that, Target Code does not include data in any format that is used as a compiler intermediate representation, or used for producing a compiler intermediate representation.

The "Compilation Process" transforms code entirely represented in non-intermediate languages designed for human-written code, and/or in Java Virtual Machine byte code, into Target Code. Thus, for example, use of source code generators and preprocessors need not be considered part of the Compilation Process, since the Compilation Process can be understood as starting with the output of the generators or preprocessors.

A Compilation Process is "Eligible" if it is done using GCC, alone or with other GPL-compatible software, or if it is done without using any work based on GCC. For example, using non-GPL-compatible Software to optimize any GCC intermediate representations would not qualify as an Eligible Compilation Process.

1. Grant of Additional Permission.

You have permission to propagate a work of Target Code formed by combining the Runtime Library with Independent Modules, even if such propagation would otherwise violate the terms of GPLv3, provided that all Target Code was generated by Eligible Compilation Processes.

You may then convey such a combination under terms of your choice, consistent with the licensing of the Independent Modules.

2. No Weakening of GCC Copyleft.

The availability of this Exception does not imply any general presumption that third-party software is unaffected by the copyleft requirements of the license of GCC.

■ About c-ares

Copyright 1998 by the Massachusetts Institute of Technology.

Permission to use, copy, modify, and distribute this software and its documentation for any purpose and without fee is hereby granted, provided that the above copyright notice appear in all copies and that both that copyright notice and this permission notice appear in supporting documentation, and that the name of M.I.T. not be used in advertising or publicity pertaining to distribution of the software without specific, written prior permission. M.I.T. makes no representations about the suitability of this software for any purpose. It is provided "as is" without express or implied warranty.

■ About WPA Supplicant

WPA Supplicant

Copyright (c) 2003-2012, Jouni Malinen <j@w1.fi> and contributors
All Rights Reserved.

This program is licensed under the BSD license (the one with advertisement clause removed).

If you are submitting changes to the project, please see CONTRIBUTIONS file for more instructions.

License

This software may be distributed, used, and modified under the terms of BSD license:

Redistribution and use in source and binary forms, with or without modification, are permitted provided that the following conditions are met:

1. Redistributions of source code must retain the above copyright notice, this list of conditions and the following disclaimer.
2. Redistributions in binary form must reproduce the above copyright notice, this list of conditions and the following disclaimer in the documentation and/or other materials provided with the distribution.
3. Neither the name(s) of the above-listed copyright holder(s) nor the names of its contributors may be used to endorse or promote products derived from this software without specific prior written permission.

THIS SOFTWARE IS PROVIDED BY THE COPYRIGHT HOLDERS AND CONTRIBUTORS "AS IS" AND ANY EXPRESS OR IMPLIED WARRANTIES, INCLUDING, BUT NOT LIMITED TO, THE IMPLIED WARRANTIES OF MERCHANTABILITY AND FITNESS FOR A PARTICULAR PURPOSE ARE DISCLAIMED. IN NO EVENT SHALL THE COPYRIGHT OWNER OR CONTRIBUTORS BE LIABLE FOR ANY DIRECT, INDIRECT, INCIDENTAL, SPECIAL, EXEMPLARY, OR CONSEQUENTIAL DAMAGES (INCLUDING, BUT NOT LIMITED TO, PROCUREMENT OF SUBSTITUTE GOODS OR SERVICES; LOSS OF USE, DATA, OR PROFITS; OR BUSINESS INTERRUPTION) HOWEVER CAUSED AND ON ANY THEORY OF LIABILITY, WHETHER IN CONTRACT, STRICT LIABILITY, OR TORT (INCLUDING NEGLIGENCE OR OTHERWISE) ARISING IN ANY WAY OUT OF THE USE OF THIS SOFTWARE, EVEN IF ADVISED OF THE POSSIBILITY OF SUCH DAMAGE.

■ About libxml2

Except where otherwise noted in the source code (e.g. the files hash.c, list.c and the trio files, which are covered by a similar licence but with different Copyright notices) all the files are:

Copyright (C) 1998-2003 Daniel Veillard. All Rights Reserved.

Permission is hereby granted, free of charge, to any person obtaining a copy of this software and associated documentation files (the "Software"), to deal in the Software without restriction, including without limitation the rights to use, copy, modify, merge, publish, distribute, sublicense, and/or sell copies of the Software, and to permit persons to whom the Software is furnished to do so, subject to the following conditions:

The above copyright notice and this permission notice shall be included in all copies or substantial portions of the Software.

THE SOFTWARE IS PROVIDED "AS IS", WITHOUT WARRANTY OF ANY KIND, EXPRESS OR IMPLIED, INCLUDING BUT NOT LIMITED TO THE WARRANTIES OF MERCHANTABILITY, FITNESS FOR A PARTICULAR PURPOSE AND NONINFRINGEMENT. IN NO EVENT SHALL THE DANIEL VEILLARD BE LIABLE FOR ANY CLAIM, DAMAGES OR OTHER LIABILITY, WHETHER IN AN ACTION OF CONTRACT, TORT OR OTHERWISE, ARISING FROM, OUT OF OR IN CONNECTION WITH THE SOFTWARE OR THE USE OR OTHER DEALINGS IN THE SOFTWARE.

Except as contained in this notice, the name of Daniel Veillard shall not be used in advertising or otherwise to promote the sale, use or other dealings in this Software without prior written authorization from him.

■ About fonts

Fonts are (c) Bitstream (see below). DejaVu changes are in public domain. Glyphs imported from Arev fonts are (c) Tavmjong Bah (see below)

Bitstream Vera Fonts Copyright

Copyright (c) 2003 by Bitstream, Inc. All Rights Reserved. Bitstream Vera is a trademark of Bitstream, Inc.

Permission is hereby granted, free of charge, to any person obtaining a copy of the fonts accompanying this license ("Fonts") and associated documentation files (the "Font Software"), to reproduce and distribute the Font Software, including without limitation the rights to use, copy, merge, publish, distribute, and/or sell copies of the Font Software, and to permit persons to whom the Font Software is furnished to do so, subject to the following conditions:

The above copyright and trademark notices and this permission notice shall be included in all copies of one or more of the Font Software typefaces.

The Font Software may be modified, altered, or added to, and in particular the designs of glyphs or characters in the Fonts may be modified and additional glyphs or characters may be added to the Fonts, only if the fonts are renamed to names not containing either the words "Bitstream" or the word "Vera".

This License becomes null and void to the extent applicable to Fonts or Font Software that has been modified and is distributed under the "Bitstream Vera" names.

The Font Software may be sold as part of a larger software package but no copy of one or more of the Font Software typefaces may be sold by itself.

THE FONT SOFTWARE IS PROVIDED "AS IS", WITHOUT WARRANTY OF ANY KIND, EXPRESS OR IMPLIED, INCLUDING BUT NOT LIMITED TO ANY WARRANTIES OF MERCHANTABILITY, FITNESS FOR A PARTICULAR PURPOSE AND NONINFRINGEMENT OF COPYRIGHT, PATENT, TRADEMARK, OR OTHER RIGHT. IN NO EVENT SHALL BITSTREAM OR THE GNOME FOUNDATION BE LIABLE FOR ANY CLAIM, DAMAGES OR OTHER LIABILITY, INCLUDING ANY GENERAL, SPECIAL, INDIRECT, INCIDENTAL, OR CONSEQUENTIAL DAMAGES, WHETHER IN AN ACTION OF CONTRACT, TORT OR OTHERWISE, ARISING FROM, OUT OF THE USE OR INABILITY TO USE THE FONT SOFTWARE OR FROM OTHER DEALINGS IN THE FONT SOFTWARE.

Except as contained in this notice, the names of Gnome, the Gnome Foundation, and Bitstream Inc., shall not be used in advertising or otherwise to promote the sale, use or other dealings in this Font Software without prior written authorization from the Gnome Foundation or Bitstream Inc., respectively. For further information, contact: fonts at gnome dot org.

Arev Fonts Copyright

Copyright (c) 2006 by Tavmjong Bah. All Rights Reserved.

Permission is hereby granted, free of charge, to any person obtaining a copy of the fonts accompanying this license ("Fonts") and associated documentation files (the "Font Software"), to reproduce and distribute the modifications to the Bitstream Vera Font Software, including without limitation the rights to use, copy, merge, publish, distribute, and/or sell copies of the Font Software, and to permit persons to whom the Font Software is furnished to do so, subject to the following conditions:

The above copyright and trademark notices and this permission notice shall be included in all copies of one or more of the Font Software typefaces.

The Font Software may be modified, altered, or added to, and in particular the designs of glyphs or characters in the Fonts may be modified and additional glyphs or characters may be added to the Fonts, only if the fonts are renamed to names not containing either the words "Tavmjong Bah" or the word "Arev".

This License becomes null and void to the extent applicable to Fonts or Font Software that has been modified and is distributed under the "Tavmjong Bah Arev" names.

The Font Software may be sold as part of a larger software package but no copy of one or more of the Font Software typefaces may be sold by itself.

THE FONT SOFTWARE IS PROVIDED "AS IS", WITHOUT WARRANTY OF ANY KIND, EXPRESS OR IMPLIED, INCLUDING BUT NOT LIMITED TO ANY WARRANTIES OF MERCHANTABILITY, FITNESS FOR A PARTICULAR PURPOSE AND NONINFRINGEMENT OF COPYRIGHT, PATENT, TRADEMARK, OR OTHER RIGHT. IN NO EVENT SHALL TAVMJONG BAH BE LIABLE FOR ANY CLAIM, DAMAGES OR OTHER LIABILITY, INCLUDING ANY GENERAL, SPECIAL, INDIRECT, INCIDENTAL, OR CONSEQUENTIAL DAMAGES, WHETHER IN AN ACTION OF CONTRACT, TORT OR OTHERWISE, ARISING FROM, OUT OF THE USE OR INABILITY TO USE THE FONT SOFTWARE OR FROM OTHER DEALINGS IN THE FONT SOFTWARE.

Except as contained in this notice, the name of Tavmjong Bah shall not be used in advertising or otherwise to promote the sale, use or other dealings in this Font Software without prior written authorization from Tavmjong Bah. For further information, contact: tavmjong @ free. fr.

ПРЕДОСТЕРЕЖЕНИЕ

Использование органов управления или произведение настроек или выполнение процедур, не указанных в данной инструкции, может отразиться на выделении опасной радиации.

CAUTION

Use of controls or adjustments or performance of procedures other than those specified herein may result in hazardous radiation exposure.

LASER Технические характеристики:

Класс 1 LASER продукт

Длина волны: 790 nm (CD)/658 nm (DVD)/405 nm (BD)

Выходная мощность лазера: не более 1 мВт

LASER Specification:

Class 1 LASER Product

Wave length: 790 nm (CDs)/658 nm (DVDs)/405 nm (BDs)

Laser output: max. 1 mW

БЕЗОПАСНОЕ ИСПОЛЬЗОВАНИЕ ЛАЗЕРА

Данное устройство содержит лазер. Из-за опасности травмы глаз, снимать крышку или обслуживать данное устройство должен только сертифицированный обслуживающий персонал.

ОПАСНОСТЬ

Данное устройство в открытом состоянии излучает видимые лазерные лучи. Не допускайте непосредственного воздействия лазерных лучей на глаза. Когда данное устройство подключено к розетке, не приближайте глаза к отверстию лотка диска и другим отверстиям, и не смотрите внутрь аппарата.

LASER SAFETY

This unit employs a laser. Due to possible eye injury, only a qualified service person should remove the cover or attempt to service this device.

DANGER

This unit emits visible laser radiation when open. Avoid direct eye exposure to beam. When this unit is plugged into the wall outlet, do not place your eyes close to the opening of the disc tray and other openings to look into inside.

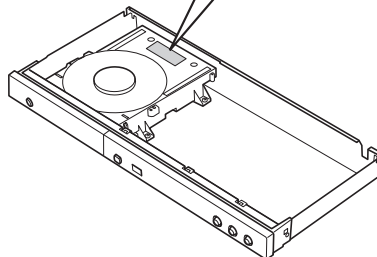
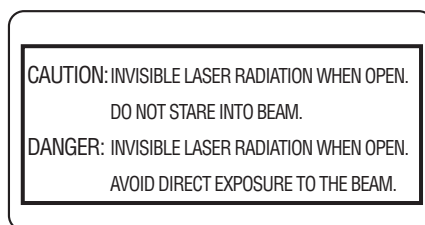
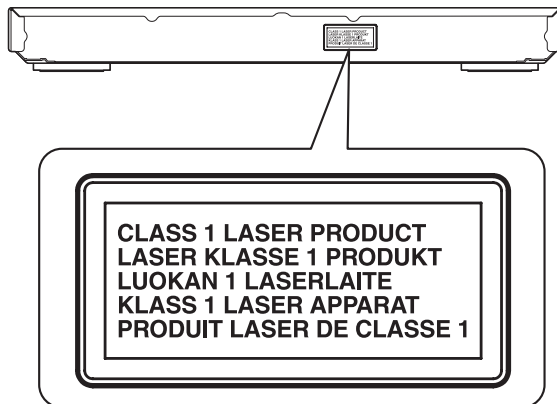

Yamaha Music (Russia) LLC.

Room 37, bld. 7, Kievskaya street,
Moscow, 121059, Russia
Tel: +7-495-626-5005



BONUS VIEW™



x.v.Color